

Name:

Enrolment No:



UNIVERSITY OF PETROLEUM AND ENERGY STUDIES

End Semester Examination, July 2020

Programme Name: B. Tech (Mechatronics)

Semester : VI

Course Name : Program Logic Controller & HMI

Time : 03 hrs.

Course Code : MECH 3006

Max. Marks : 100

Nos. of page(s) : 8

Instructions : All questions are compulsory.

1. Read the instruction carefully before attempting.
2. This question paper has two section, Section A and Section B.
3. There are total of six questions in this question paper. **One in Section A and five in Section B**
4. **Section A** consist of multiple choice based questions and has the total weightage of 25%.
5. **Section A** will be conducted online on BB Collaborate platform
6. **Section B** consist of long answer based questions and has the total weightage of 75%. The questions for section B shall also appear in BB Collaborate
7. The maximum time allocated to **Section A** is one Hrs.
8. **Section B** to be submitted within 24 hrs from the scheduled time (*exceptional provision due extraordinary circumstance due to COVID-19 and due to internet connectivity issues in the far-flung areas*).
9. No submission of **Section B** shall be entertained after 24 Hrs.
10. **Section B** should be attempted after **Section A**
11. **The section B** should be attempted in blank white sheets (hand written) with all the details like programme, semester, course name, course code, name of the student, Sapid at the top (as in the format) and signature at the bottom (right hand side bottom corner)
12. Both section A & B have questions from entire syllabus.

SECTION A

All questions are compulsory and carry equal marks. (25*1 = 25 Marks)

S. No.		Marks	CO
Q 1	<p>[1] Decide whether each of these statements is true (T) or false (F): A transistor output channel from a PLC:</p> <ul style="list-style-type: none"> i. Is used for only DC switching. ii. Is isolated from the output load by an optocoupler. <p>Which option best describes the two statements?</p> <ul style="list-style-type: none"> A. (i) T (ii) T B. (i) T (ii) F C. (i) F (ii) T D. (i) F (ii) F <p>[2] Decide whether each of these statements is true (T) or false (F): A relay output channel from a PLC:</p> <ul style="list-style-type: none"> i. Is used for only DC switching. ii. Can withstand transient overloads. <p>Which option best describes the two statements?</p> <ul style="list-style-type: none"> A. (i) T (ii) T B. (i) T (ii) F C. (i) F (ii) T D. (i) F (ii) F <p>[3] Decide whether each of these statements is true (T) or false (F): A triac output channel from a PLC:</p> <ul style="list-style-type: none"> i. Is used for only AC output loads. ii. Is isolated from the output load by an optocoupler. <p>Which option best describes the two statements?</p> <ul style="list-style-type: none"> A. (i) T (ii) T B. (i) T (ii) F C. (i) F (ii) T D. (i) F (ii) F <p>[4] Which of the following is most likely to be the voltage level used internally in a PLC, excluding the voltage levels that might occur during conditioning in input/output channels?</p> <ul style="list-style-type: none"> a. 5 V b. 24 V c. 110 V d. 240 V <p>[5] Decide whether each of these statements is true (T) or false (F): The reason for including optocouplers on input/output units is to:</p> <ul style="list-style-type: none"> i. Provide a fuse mechanism that breaks the circuit if high voltages or currents occur. ii. Isolate the CPU from high voltages or currents. 	<p>25*1 = 25</p>	<p>5Q CO1</p> <p>5Q CO2</p> <p>5Q CO3</p> <p>5Q CO4</p> <p>5Q CO5</p>

Which option best describes the two statements?

- A. (i) T (ii) T
 - B. (i) T (ii) F
 - C. (i) F (ii) T
 - D. (i) F (ii) F
- [6] Decide whether each of these statements is true (T) or false (F). A limit switch:
- i. Can be used to detect the presence of a moving part.
 - ii. Is activated by contacts making or breaking an electrical circuit.
- A. (i) T (ii) T
 - B. (i) T (ii) F
 - C. (i) F (ii) T
 - D. (i) F (ii) F
- [7] An incremental shaft encoder gives an output that is a direct measure of:
- i. The diameter of the shaft.
 - ii. The change in diameter of the shaft.
 - iii. The change in angular position of the shaft.
 - iv. The absolute angular position of the shaft.
- [8] A stepper motor has a step angle of 7.5 degree. The digital input rate required to produce a rotation of 10 rev/s is:
- i. 48 pulses per second
 - ii. 75 pulses per second
 - iii. 480 pulses per second
 - iv. 750 pulses per second
- [9] A 12-bit ADC can be used to represent analog voltages over its input range with:
- a. 12 different binary numbers
 - b. 24 different binary numbers
 - c. 144 different binary numbers
 - d. 4096 different binary numbers
- [10] For an analog input range of 0 to 10 V, the minimum size ADC needed to register a change of 0.1 V is:
- A. 4-bit
 - B. 6-bit
 - C. 8-bit
 - D. 12-bit
- [11] Decide whether each of these statements is true (T) or false (F). A serial communication interface:
- i. Involves data being transmitted and received one bit at a time.
 - ii. Is a faster form of transmission than parallel communication.
- A. (i) T (ii) T
 - B. (i) T (ii) F
 - C. (i) F (ii) T

D. (i) F (ii) F

[12] Decide whether each of these statements is true (T) or false (F). The RS232 communications interface:

i. Is a serial interface.

ii. Is typically used for distances up to about 15 m.

A. (i) T (ii) T

B. (i) T (ii) F

C. (i) F (ii) T

D. (i) F (ii) F

[13] Decide whether each of these statements is true (T) or false (F). Every time there is an input to UP Counter and assume preset value is 5 then

(i) The count accumulated by the counter decreases by 1.

(ii) The output is switched on.

A. (i) T (ii) T

B. (i) T (ii) F

C. (i) F (ii) T

D. (i) F (ii) F

[14] Decide whether each of these statements is true (T) or false (F). Every time there is an input to UP Counter and assume preset value is 5 then

(i) The count accumulated by the counter increased by 1.

(ii) The output is switched on when current value is greater than equal to PV.

A. (i) T (ii) T

B. (i) T (ii) F

C. (i) F (ii) T

D. (i) F (ii) F

[15] Decide whether each of these statements is true (T) or false (F). When there is an input to RESET terminal of the UP counter assuming PV is 5.

(i) Resets to a value of 5.

(ii) Starts counting from 0.

A. (i) T (ii) T

B. (i) T (ii) F

C. (i) F (ii) T

D. (i) F (ii) F

[16] Decide whether each of these statements is true (T) or false (F). When there is an input to RESET terminal of the DOWN counter assuming PV is 5.

(i) Resets to a value of 5.

(ii) Starts counting from 5.

A. (i) T (ii) T

B. (i) T (ii) F

C. (i) F (ii) T

D. (i) F (ii) F

[17] The principle reason for leaving certain portions of the control circuit hardwired is to:

- a. minimize wiring
- b. avoid failure of main magnetic elements
- c. ensure safety
- d. keep some devices running at all times

[18] The PLC fault contacts are wired to other hardwired emergency circuit elements:

- a. in parallel
- b. in series
- c. normally open
- d. normally closed

[19] The main reason the PLC fault contacts are included in the hardwired circuit is:

- a. to prevent system shut down
- b. to detect I/O failures
- c. to include the PLC as an emergency stop condition
- d. to shut down the system if there is a PLC failure

[20] Logic sequences for a control program can be created using:

- a. logic gates
- b. relay ladder symbology
- c. PLC contact symbology
- d. all of the above

[21] System operation for new applications usually begins with:

- a. sample diagrams
- b. specifications
- c. the control strategy
- d. logic diagrams

[22] Hardwire control means?

- a. Controlling the hardware with the help of software.
- b. Controlling the plant with relays contactors etc. without any programmable controller
- c. Controlling the plant with relays contactors etc. with programmable controller
- d. None

[23] Solenoids, lamps, motors are connected to

- a) Analog input
- b) Analog output
- c) Digital input
- d) Digital output

[24] How the instruction NC contact in the PLC language work?

- a) It detects the signal state from 0 to 1.
- b) It detects the signal state from 1 to 0 and remains close till signal is 0.
- c) It detects the signal state from 1 to 0 and remains close for one scan cycle only.

	<p>d) When signal state is 1 this instruction remains close.</p> <p>[25] Full name of DCS is?</p> <p>a) Designed Control System</p> <p>b) Distributed Control System</p> <p>c) Display Control System</p> <p>d) Dedicated Control System</p>		
--	--	--	--

SECTION B
Answer all the questions.

Q 2	<p>A process is supposed to have exactly 15 parts on it. You have three indicating lights to indicate the conveyor count status: less than 15, yellow: exactly 15, green: and more than 15, red. The count of parts on the conveyor is set at 15 each morning by an actual count of parts. There are two sensors on the conveyor, one is actuated by parts entering the conveyor, and the other is actuated by parts leaving. Design a PLC program to carry out this process, the system should also include a start and stop button.</p>	15	CO2
-----	---	-----------	------------

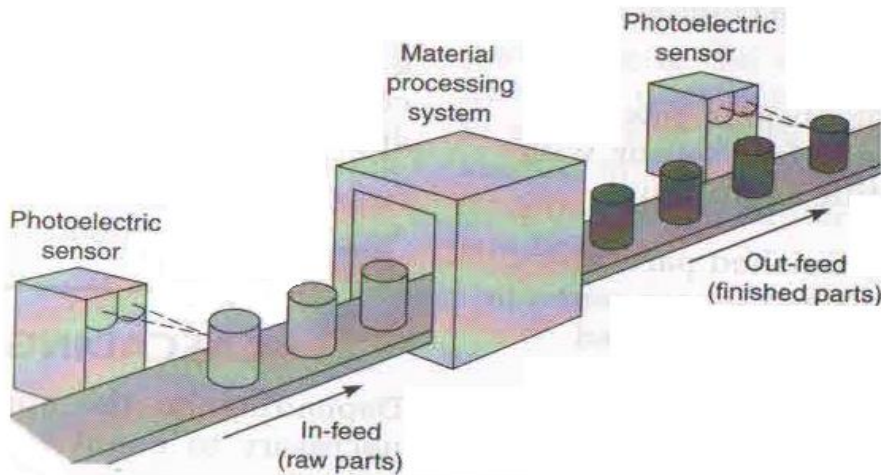

Q 3	<p>Write a PLC program to implement the bending device for sheet metal parts is to be performed on a work piece. The sequence of motion of cylinders is:</p> <p>a. Cylinder 1 clamp the work piece</p> <p>b. Cylinder 2 performs bending operation on a work piece</p> <p>c. Cylinder 2 return backs</p> <p>d. Cylinder 3 performs bending operation on a work piece</p> <p>e. Cylinder 3 return backs</p> <p>f. Cylinder 1 unclamps the work piece. (Consider 5/2 impulse directional control valve)</p>	15	CO4
-----	---	-----------	------------

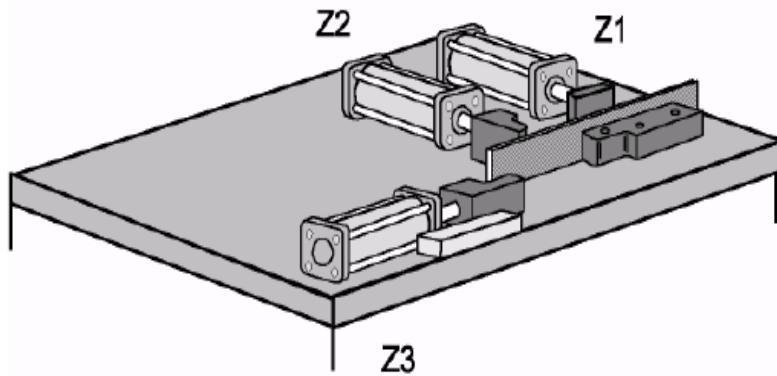

Example of application: "Bending aluminum into hooks"

Q 4 Design a PLC ladder diagram and draw hardware configuration for the DC motor control using PWM method. With potentiometer vary the duty cycle and accordingly speed of the motor should change. Shown in below figure, use appropriate relay to match the current rating. (Motor Rating 24V/ 2.2 A)

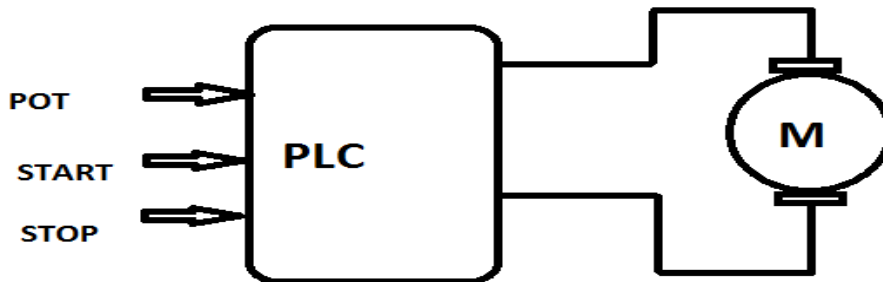

15

CO5

Q5 4 tanks that can be manually emptied are filled from one joint storage tank using 4 pumps. For the "Max" (full) notification and the "Min" (empty) notification, each tank has a signal encoder. The pumps have different connected loads.

- Pump 1: 3 kW
- Pump 2: 2 kW
- Pump 3: 7 kW
- Pump 4: 5 kW

A control is to secure that in the "Max" (full) notification regarding one tank, the latter is automatically refilled. In doing so, the connected load of 10 kW must not be exceeded.

1. Determine the type of the signal encoders and receivers used and list them.
2. Prepare a variable declaration chart
3. Prepare the PLC program.

15

CO3

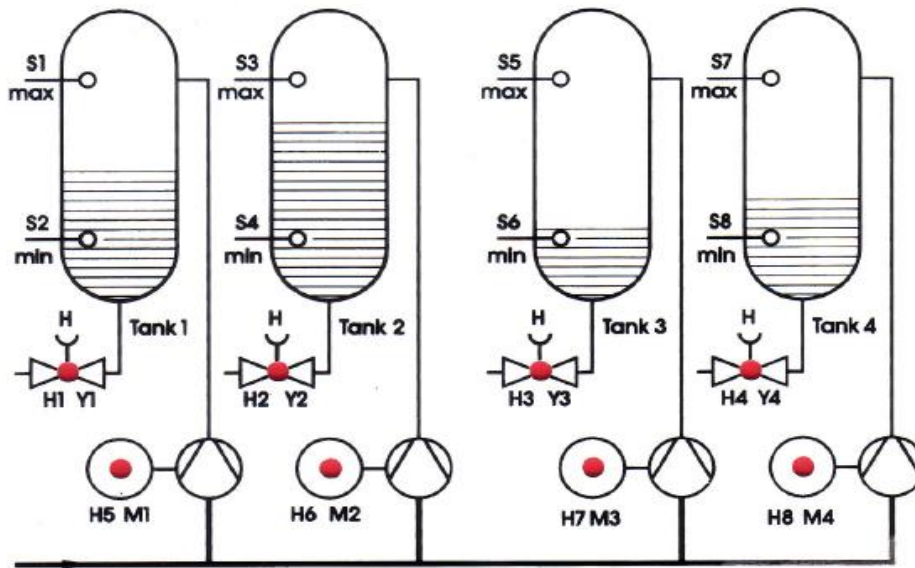

Q6

For the stepper motor, consider minimum step angle is 1° and pulse train to run the motor is generated by the PLC.

a) How many pulses are required to rotate the motor through five complete revolutions?

b) If it is desired to rotate the motor at a speed of 25 rev/min, what pulse rate must be generated by the robot controller?

Write ladder logic program to rotate the stepper motor 5 times in clockwise and 5 times in counter clockwise direction.

OR

A conveyor is supposed to have exactly 45 parts on it. You have three indicating lights to indicate the conveyor count status: less than 45, yellow: exactly 45, green: and more than 45, red. The count of parts on the conveyor is set at 45 each morning by an actual count of parts. There are two sensors on the conveyor, one is actuated by parts entering the conveyor, and the other is actuated by parts leaving. Design a PLC program to carry out this process.

15

CO1