

**DEVELOPMENT
OF
OIL FIELD**

Submitted for the Partial fulfillment of
BACHELOR OF TECHNOLOGY
(Applied Petroleum Technology)
(Session: September 2005 to May 2009)



Submitted to:

University of Petroleum & Energy Studies, Bidholi, Dehradun

Under the guidance of: **Dr. B.P. Pandey & Dr. Sant Kumar**

Submitted By:

Dharna Singh

&

D. Rama Krishna Rao

University of Petroleum & Energy Studies, Bidholi, Dehradun

May, 2009

UPES - Library



D1951

SIN-2009BT

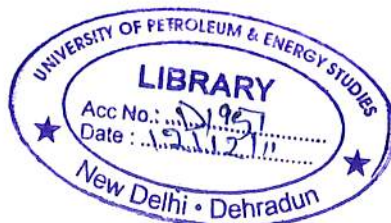

**DEVELOPMENT
OF
OIL FIELD**

Submitted for the Partial fulfillment of
BACHELOR OF TECHNOLOGY
(Applied Petroleum Technology)
(Session: September 2005 to May 2009)



Submitted to

University of Petroleum & Energy Studies, Bidholi, Dehradun

Under the guidance of: **Dr. B.P. Pandey & Dr. Sant Kumar**

Submitted By:

Dharna Singh

&

D. Rama Krishna Rao

University of Petroleum & Energy Studies, Bidholi, Dehradun

May, 2009





UNIVERSITY OF PETROLEUM & ENERGY STUDIES

CERTIFICATE

This is to certify that the dissertation report on “Development of an oil field” completed and submitted to the University of Petroleum & Energy Studies, Dehradun by **Ms. Dharna Singh and Mr D. Rama Krishna Rao**, in partial fulfilment of the requirement for the award of degree of Bachelor of Applied Petroleum Engineering is a bonafide work carried out by them under my supervision and guidance.

To the best of my knowledge and belief the work has been based on investigation made, data collected and analyzed by them and this work has not been submitted anywhere else for any other University or Institution for the award of degree/diploma.

Dr. B.P. Pandey
Dean Emeritus, Professor of Eminence

Dr. Sant Kumar
Visiting Professor, UPES
Ex-Professor, ISM, Dhanbad
Ex-Director, IMD, GM (Res.),
ONGC

Date:

Date: 7.5.09

Corporate Office:

Hydrocarbons Education & Research Society
3rd Floor, PHD House,
4/2 Siri Institutional Area
August Kranti Marg, New Delhi - 110 016 India
Ph.: +91-11-41730151-53 Fax: +91-11-41730154

Main Campus:

Energy Acres,
PO Bidholi Via Prem Nagar,
Dehradun - 248 007 (Uttarakhand), India
Ph.: +91-135-2102690-91, 2694201/ 203/ 208
Fax: +91-135-2694204

Regional Centre (NCR):

SCO, 9-12, Sector-14,
Gurgaon 122 007
(Haryana), India.
Ph: +91-124-4540 300
Fax: +91-124-4540 330

Regional Centre (Rajahmundry):

GIET, NH 5, Velugubanda,
Rajahmundry - 533 294,
East Godavari Dist., (Andhra Pradesh), India
Tel: +91-883-2484811/ 855
Fax: +91-883-2484822

ACKNOWLEDGEMENT

This project bears imprints of many people.

We are thankful to *University of Petroleum & Energy Studies* for giving us this opportunity to carry out our major project on "*Development of Oil Field*"

We would like to thank *KDMIPE- ONGC, Dehradun and IRS- ONGC, Ahmedabad* for permitting us to access their library and also providing us with their valuable time to explain the doubts and difficulties. We are grateful for their assistance throughout the project.

We are indebted to our guide *Dr. B.P. Pandey (Dean Emeritus, Professor of Eminence, College of Engineering)* and *Dr. Sant Kumar Ex-Director, IMD, Ex. GM (Res.), ONGC, Ex-professor, ISM, Dhanbad, Visiting Professor, UPES, Dehradun* for their valuable and erudite guidance, keen interest and constructive suggestions, timely and generous help beyond measures at all stages during the progress of the project work.

Dharna Singh

&

D.Rama Krishna Rao

(B.Tech, Applied Petroleum Engineering)

University of Petroleum & Energy Studies

Dehradun

CONTENTS

LIST OF FIGURES	v
LIST OF TABLES	viii
ABBREVIATIONS	ix
ABSTRACT	xi
Chapter 1: INTRODUCTION TO FIELD DEVELOPMENT	1
Chapter 2: BASIC GEOLOGY FOR PETROLEUM RECOVERY	2
2.1 Rocks.....	4
2.2 Tectonics	4
2.3 Reservoir Traps	6
2.4 Principles of basin analysis	9
2.5 Migration.....	9
2.6 Structure contour maps	10
Chapter 3: WELL LOGGING	12
3.1 Introduction	12
3.2 Spontaneous Potential.....	13
3.3 Gamma Ray.....	15
3.4 Porosity Calculations – sonic, density, and neutron logs.....	16
Chapter 4: RESERVOIR ROCK AND FLUID PROPERTIES	21
4.1 Saturation	21
4.2 Porosity	23
4.3 Permeability	25
4.4 Wettability	26
4.5 Capillary Pressure.....	27
4.6 Surface and Interfacial tension.....	28
4.7 Rock Compressibility	28
4.8 Crude Oil Gravity	28
4.9 Oil Formation Volume Factor	28
4.10 Crude Oil Viscosity	29
4.11 PVT Analysis Of Reservoir Fluid.....	29
Chapter 5: WELL TESTING AND IT'S INTERPRETATION.....	33
5.1 Role of Oil Well Tests and Information in Petroleum Industry	33
5.2 Productivity Well Testing	33

5.3 Pressure Buildup Test:	35
5.4 Skin	35
5.5 Pressure Draw down Test.....	37
5.6 Type Curves	38
5.7 Reservoir Heterogeneities	39
Chapter 6: ESTIMATION OF RESERVES.....	40
6.1 Introduction	40
6.2 Volumetric Method For Determining Original Oil-In-Place	43
6.3 Material Balance Determination of Hydrocarbons In Place.....	45
6.4 Decline Curve Analysis	50
6.5 Reservoir Simulation	53
6.6 Oil Reservoirs.....	54
6.7 Primary Recovery Mechanisms.....	55
Chapter 7: PETRO ECONOMICS.....	56
7.1 Cash Flow Analysis	56
7.2 Mineral Rights Ownership	56
7.3 Principal Sources And Uses Of Cash	57
7.4 Federal Corporate Income Tax.....	61
7.5 Financial Statements.....	62
7.6 Finance And Economic Considerations.....	62
7.7 Uncertainty And Risk In Reserve Evaluation	63
7.8 EXAMPLE 1	66
7.9 EXAMPLE 2	70
Chapter 8: CASE STUDY.....	80
8.1 Introduction	80
8.2 Well Spacing	81
8.3 Evolution of Well- Spacing Concepts	81
8.4 Iso Pay Maps	90
8.5 Some Properties of the reservoir	97
8.6 Calculation of reservoir permeability	107
Chapter 9: CONCLUSION.....	118
REFERENCES	119

LIST OF FIGURES

Figure- 2(a) Geological Time Scale

Figure- 2(b) Types of Fold

Figure- 2(c) Types of Fault

Figure- 2(d) Types of Structural Traps

Figure- 2(e) Types of Stratigraphic Traps

Figure- 3(a) Idealized SP log

Figure- 3(b) Idealized GR and SGR log

Figure- 3(c) Idealized Sonic log

Figure- 3(d) Idealized Density log

Figure- 3(e) Idealized Neutron log

Figure – 3(f) Schematic illustration of three formations with same porosity but Different values of F (formation factor).

Figure-4 (a) Variation of Capillary pressure with permeability

Figure 4(b) Bo as a function of pressure in differential liberation experiment

Figure- 4(c) Viscosity as a function of Pressure

Figure-4(d) Schematic illustration of constant mass expansion experiment for gas
Condensate

Figure- 4(e) Schematic representation of constant volume depletion experiment

Figure- 4(f) Schematic representation of differential liberation experiment

Figure- 5(a) typical inflow performance curves showing low (a) and high (b)
Productivity.

Figure- 5 (b) Ideal pressure build-up test

Figure- 5(c) Skin open-holes

Figure- 5(d) Positive skin

Figure- 5 (e) Negative Skin

Figure- 5(f) Schematic pressure-time histories for a constant-rate drawdown test

Figure- 5 (g) Type curves for constant production rate, infinite-acting reservoir

Figure -6(a) Top-of-structure map of a hydrocarbon reservoir

Figure- 6(b) Net sand isopach map for a hydrocarbon reservoir

Figure- 6(c) Cross-section and isopachous map of an idealized reservoir

Figure- 6(d) Reservoir pressure survey showing isobaric lines drawn from the
Measured bottom-hole pressures

Figure- 6(e) Simulator

Figure- 7(a) probability density function (PDF) of net present value.

Figure- 7(b) cumulative distribution function (CDF) or expectation curve of net present values.

Figure-7(c) expectation curve: (reconciliation of different views of hydrocarbon volumes and values.)

Figure-7(d) plot of production rate Vs time

Figure- 8(a) Iso-Pay Thickness Map of Sand-Suraj Pay, Sand I, Santhal

Figure- 8 (b) Iso Pay thicknesses Map of Sand II, Santhal

Figure- 8 (c) Iso Pay thicknesses Map Of Sand III, Santhal

Figure- 8(d-1) Geological Cross Section

Figure- 8(d-2) Geological Cross Section

Figure- 8 (e) Pressure Vs Rs

Figure- 8(f) Pressure Vs B_0 (SandI and SandII)

Figure- 8(g) Pressure Vs B_0 Sand III + Lower Sands (L.S)

Figure- 8(h) Pressure Vs Viscosity (Santhal)

Figure- 8(i) Indicator Diagram's of $300 \times 300 \text{ m}^2$ spacing:

Figure- 8 (j-1) Indicator Diagram of $250 \times 300 \text{ m}^2$ spacing for well no: 9

Figure- 8 (j-2) Indicator Diagram of $250 \times 300 \text{ m}^2$ spacing for well no: 14

Figure- 8 (j-3) Indicator Diagram of $250 \times 300 \text{ m}^2$ spacing for well no: 38

Figure- 8 (j-4) Indicator Diagrams of $250 \times 300 \text{ m}^2$ spacing for well no: 35

Figure- 8(k) Pressure Build up plot of well no: 9

Figure- 8 (l) Pressure build-up plots of well no 14

Figure- 8(m) Pressure build-up plot of well no 38

Figure- 8 (n) Pressure build-up plots of well no 41

Figure-(8o-1): well spacing pattern for sand-1 formation

Figure-(8o-2): well spacing pattern for sand-1 formation

Figure-(8p-1): well spacing pattern for sand-II formation

Figure-(8p-2): well spacing pattern for sand-II formation

Figure-(8q-1): well spacing pattern for sand-III formation

Figure-(8q-2): well spacing pattern for sand-III formation

LIST OF TABLES

Table 1: Common wire-line geophysical well measurements (Rider, 1996).....	12
Table 2: Principal uses of the SP log	13
Table 3: Nomenclature Used In The Archie's Equation	20
Table 4: Decline curve equations.....	51

ABBREVIATIONS

P_i = Initial reservoir pressure, psi

p = Volumetric average reservoir pressure

Δp = Change in reservoir pressure = $p_i - p$, psi

p_b = Bubble point pressure, psi

N = Initial (original) oil in place, STB

N_p = Cumulative oil produced, STB

G_p = Cumulative gas produced, scf

W_p = Cumulative water produced, bbl

R_p = Cumulative gas-oil ratio, scf/STB

GOR = Instantaneous gas-oil ratio, scf/STB

R_{si} = Initial gas solubility, scf/STB

R_s = Gas solubility, scf/STB

B_{oi} = Initial oil formation volume factor, bbl/STB

B_o = Oil formation volume factor, bbl/STB

B_{gi} = Initial gas formation volume factor, bbl/scf

B_g = Gas formation volume factor, bbl/scf

W_{inj} = Cumulative water injected, STB

G_{inj} = Cumulative gas injected, scf

W_e = Cumulative water influx, bbl

m = Ratio of initial gas-cap-gas reservoir volume to initial reservoir oil volume, bbl/bbl

G = Initial gas-cap gas, scf

$P.V$ = Pore volume, bbl

C_w = Water compressibility, psi⁻¹

C_f = Formation (rock) compressibility, psi⁻¹

NPV = Net Present Value

IRR = Internal Rate of Return

P.I = Productivity Index

PDF = Probability Density Function

WACC = Weighted Average Cost of Capital

CCA = Capital Cost Allowance

SP = Spontaneous Potential

L.S = Lower Sands

ABSTRACT

Oil and Natural gas play an immense role in the growth of industry and so the upliftment of the country. Due to industrialization in the country the demand of oil and gas will continue to increase with passage of time. Keeping the objective in mind it is important to develop the oil and gas fields in the most rational way.

In this project, we have worked on the development of an oil field, which geologically falls in Ahmedabad- Mehsana tectonic block of north-cambay Basin. The key to success is to integrate geological, geophysical, petrophysical, Reservoir performance data, well testing, Techno economics, well spacing etc. To form the most accurate description of the reservoir.

Complete literature to develop an oil field is been given in this report and detailed study was undertaken to prepare a technological scheme for the development of heavy oil belt. The heavy oil belt that has been studied in this report comprises of santhal field.

Main areas of interest were well-spacing and Techno-Economic Evaluation.

The data used by us has been moderated as per the needs, though the basic data has been taken from O.N.G.C

Chapter 1: INTRODUCTION TO FIELD DEVELOPMENT

Introduction:

Oil and natural gas play an immense role in the growth of industry and so the upliftment of the country.

The Development of the reservoir starts as soon as the hydrocarbon bearing area is delineated and only few wells have been drilled. It is required to produce the hydrocarbons from this area so as to achieve maximum recovery with minimum production cost. This scheme is classified as the Technological scheme for the development of the oil/gas field. This scheme is based on the meager data available from the few wells drilled as exploratory wells and is basically to get the financial sanctions. The plan is supposed to give the value of oil/gas reserves present, how to produce, technique of production, economic life of field etc.

Strategy of development:

The strategy of development of any field depends on various factors.

- 1) Location of field: It can be situated onshore or offshore.
- 2) Size of the field: It may be a giant field or a medium size or small size field. The costs of development depend on the size of field.
- 3) Lithology: the producing reservoir rock may have formation consisting of limestone or sandstone.
- 4) Pay Zone: Single layered or multi layered reservoir.
- 5) Fluid Properties: It may be a oil or gas field Under oil field it may contain volatile oil or high GOR, light oil or normal crude oil. The crude may have different pour point. The presence of corrosive gas may also change the development strategy.
- 6) Drive Mechanism: The recovery is minimum in solution gas drive and maximum in water drive.
- 7) Traps: Three types of traps occur in the formation.
- 8) Logistics
- 9) Socio-Economic conditions

Chapter 2: BASIC GEOLOGY FOR PETROLEUM RECOVERY

Geology deals with the study of earth. The actual location of the reservoir pool is made by drilling but the proper location of the wild cat well to test a trap, the depth up to which it should be drilled, and the detection and outlining of the oil or gas pool are wholly geologic problems.

- 1) **Global geology:** It deals with the earth. Since its birth the earth has been going through constant changes, these changes have resulted in the origin and accumulation of petroleum too. It is a well known fact that earth's crust consists of 15 different main plates. The tectonic plates may approach each other or may move away from each other, or may slip beside each other obliquely. All these movements may promote both the sedimentation and formation of traps.
- 2) **Stratigraphy:** this is a specialized form of geological science, which analyses the layered structure of the sedimented rocks and takes into account the time of the sediment formation in chronological order.

EON	ERA	PERIOD	EPOCH	Ma		
Phanerozoic	Cenozoic	Quaternary	Holocene	0.01 -		
			Pleistocene	Late	0.8 -	
		Early		1.8 -		
		Tertiary	Neogene	Pliocene	Late	3.6 -
					Early	5.3 -
				Miocene	Late	11.2 -
					Middle	16.4 -
					Early	23.7 -
			Paleogene	Oligocene	Late	28.5 -
					Early	33.7 -
				Eocene	Late	41.3 -
					Middle	49.0 -
					Early	54.8 -
		Paleocene	Late	61.0 -		
	Early		65.0 -			
	Mesozoic	Cretaceous	Late	99.0 -		
			Early	144 -		
		Jurassic	Late	159 -		
			Middle	180 -		
			Early	206 -		
			Late	227 -		
		Triassic	Middle	242 -		
			Early	248 -		
			Late	256 -		
			Early	290 -		
	Paleozoic	Permian	Late	323 -		
			Early	354 -		
		Pennsylvanian		370 -		
		Mississippian		391 -		
		Devonian	Late	417 -		
Middle			423 -			
Early			443 -			
Silurian		Late	458 -			
		Early	470 -			
Ordovician		Late	490 -			
		Middle	500 -			
		Early	512 -			
Cambrian		D	520 -			
		C	543 -			
		B				
		A				
Precambrian	Proterozoic	Late	900 -			
		Middle	1600 -			
		Early	2500 -			
	Archean	Late	3000 -			
		Middle	3400 -			
		Early	3800?			

Figure- 2(a) Geological Time Scale

- 3) **Lithology:** It deals with the description of the texture of different rock types. This is important for the determination of the lithostratigraphic profile of the reservoir, the delineation of the different rock bulks, which form the reservoir and the determination of rock regimes. The rock consists of minerals, which determine their physical and chemical properties.

2.1 Rocks:

According to their origin rocks are divided into three major groups' magmatic, sedimentary and metamorphic rocks. This classification of rock is imp from both the respective exploration and recovery point of view. Hydrocarbon origin is bound to sedimentary origin only. Any rock with appropriate permeability may be a reservoir trap. Therefore the lithology and pore space of all the three types of rocks have to be dealt with.

Magmatic rock: They are formed due to crystallization of magma. Magma is essentially a silicate fluid, which contains beside oxygen other elements such as Al, Fe Ca, Na, K and Mg. Magmatic rocks can never be a source rock but they can form the reservoir. These rocks are suitable for reservoir trapping.

Sedimentary rocks: they may be a source rock and a reservoir as well. They are divided into two major groups clastic and carbonate reservoirs.

2.2 Tectonics:

It deals with geological structures and their spatial reconstruction and presentation.

These structures may be formed in different ways: under the influence of forces (faults and folds); or by erosion; by the change of the inner structure of rocks (cementation, solution, fractures etc); or by combination of these processes.

Due to the processes of elevation and subsidence, sedimentary rocks are formed and they accumulate. The final result of the structural activity is the formation of a trap.

It is very important to investigate of the chronological order of a geological process.

It is important to know the spatial distribution of the structure because this defines the recovery technology (i.e. Well pattern, type of injection, location of perforation etc).

The geologist has to plot the three dimensional picture of the given geological structure and to delineate it for determination of the hydrocarbon resources.

Tectonic elements are explained as follows:

Fold: Folding takes place due to outer forces. It may be anticline or syncline.

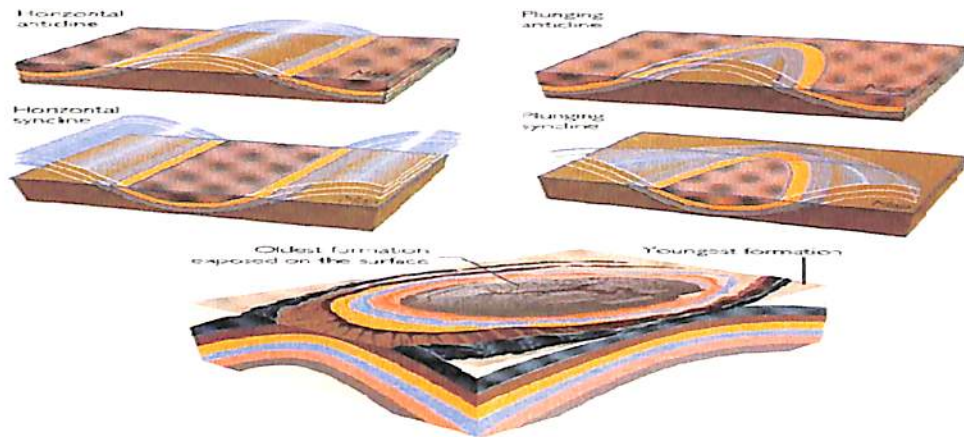

Figure- 2(b) Types of Fold

Fault:

A fault is a plane along which the formerly continuous rock bodies move away from each other. The continuity of rock is interrupted. The fault may be dip slip fault or strike slip fault.

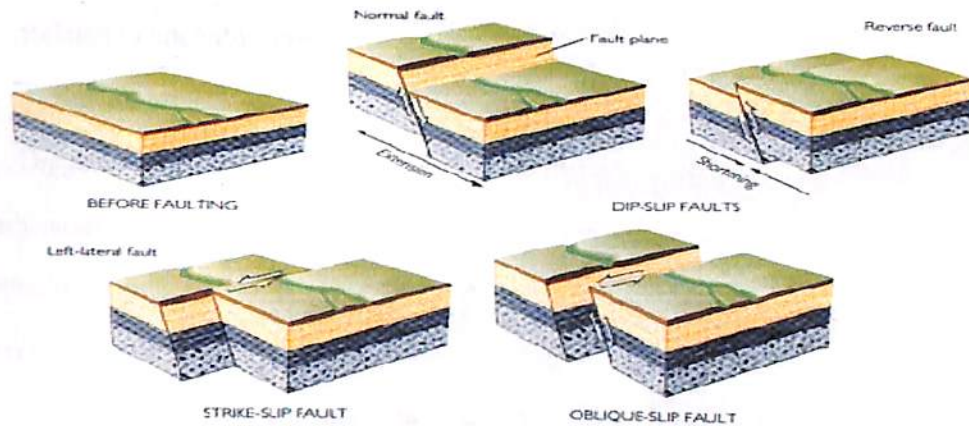

Figure- 2(c) Types of Fault

2.3 Reservoir Traps:

A trap is a geological structure, which enables the accumulation and production of crude oil and natural gas.

Main elements of a trap are:

- Reservoir rock: porous and permeable, covered by a top layer which is impermeable.
- Closure- difference between depth of spill point and depth of the highest pay.
- Spill point: the largest depth at which the reservoir fluid according to the density, can accumulate.

Knowledge about the development of the trap, the form of the trap and their closure types is important from the aspects of both exploration and production.

Classification of traps:

Structural Traps

Fold related

Fault related

Diapirs

Stratigraphic traps

Related to unconformities

Sedimentological

Diagenetic

Hydrodynamic traps

Combination traps

Fault related traps:

The key question is whether or not a fault will be a seal. It partly depends on whether the fault places a permeable or impermeable unit in contact with the reservoir. In some cases the fault itself can be sealing. Faults in extensional settings have a greater chance of being open to migration.

Normal fault traps: Roll over anticlines related to curved faults

Tilted fault blocks

Thrust fault traps:

Parts of a fold and thrust belt. Faulted anticlines, tilted fault blocks, ramp anticlines, drag folds on the footwall

Strike slip traps:

Positive and negative flower structures related to bends of the fault

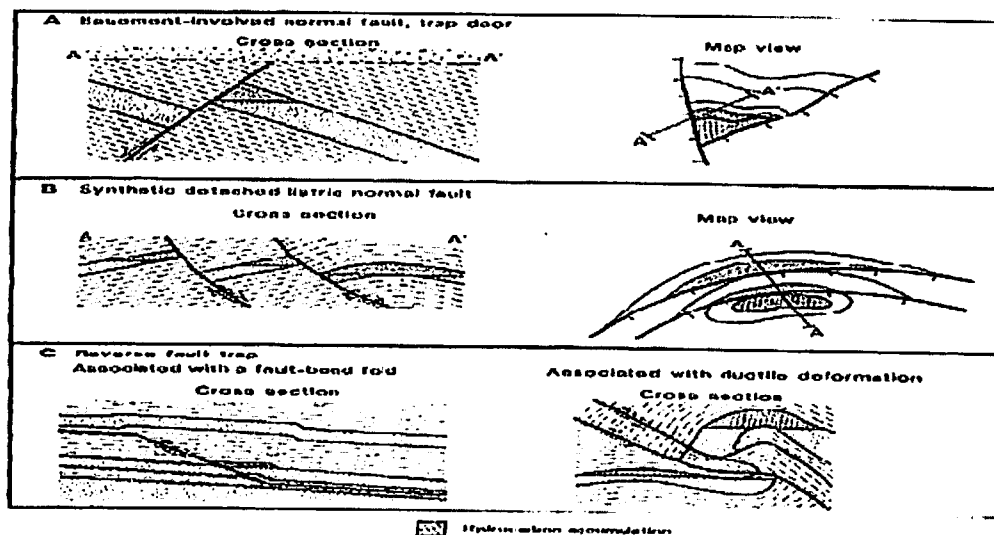

Figure- 2(d) Types of Structural Traps

Diapirs:

Salt is driven upward by buoyancy of the salt after compaction of the surrounding sediments. There can be many traps above, and surrounding a salt diapir.

In addition to diapirs there are salt-withdrawal structures (turtle backs). Salt is frequently deposited in restricted basins during the early development of a rift system, so they are often associated with extensional tectonic settings.

Stratigraphic Traps:

The main trapping mechanism is a Stratigraphic feature such as an unconformity, a lateral change in facies from reservoir rocks to seal rocks, or a Diagenetic change from non-cemented to cemented rock.

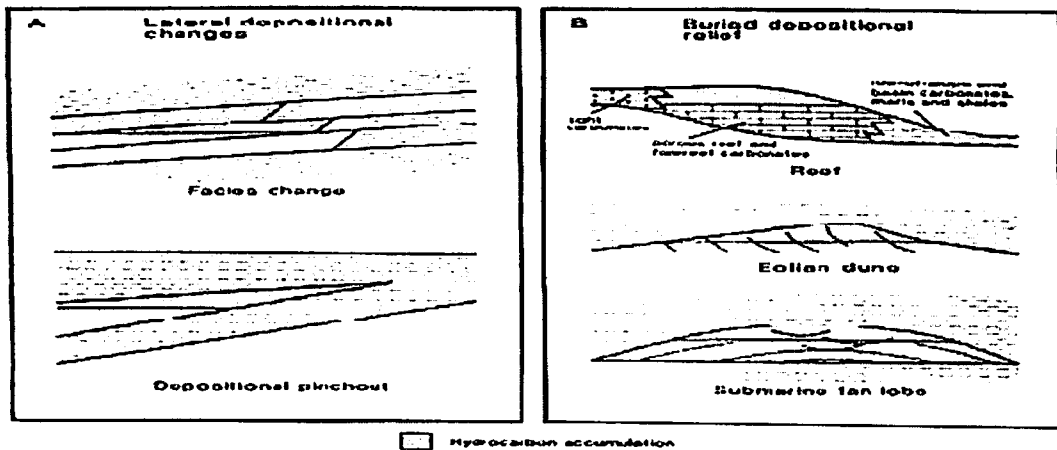

Figure- 2(e) Types of Stratigraphic Traps

Traps related to unconformities:

The hydrocarbons can be trapped below the unconformity by truncation, or above the unconformity when a porous bed laps against the unconformity surface. Often a structural element such as tilting is required, so many of these traps can be considered combination traps.

Diagenetic traps:

These are more common in carbonate reservoirs which are more easily affected by cementation, dissolution and dolomitisation. These post-depositional processes lead to a lateral change in reservoir quality to acts as the trapping mechanism.

Sedimentological traps:

Several depositional systems will produce isolated bodies of porous rock surrounded by impermeable rock. Examples are:

- Point bar sands surrounded by flood-plain clays in a fluvial system.
- Distributary channels within deltaic muds.
- Reefs within lagoon and marine shale's
- Barrier island sands also within lagoon and marine shale's

The picture above corresponds to oil fields in the Golden Lane of the Mexican Gulf coast. The oil deposits are a set of Cretaceous reefs, part of an ancient atoll.

The diagram below is an example of barrier island sands from Kansas. They form long, linear traps surrounded in shale.

Hydrodynamic traps:

In some rare cases the movement of water can modify the geometry of an oil accumulation (tilted OWC is the most common example), or even trap the oil in a location where it would otherwise escape.

2.4 Principles of basin analysis:

During the basin analysis one has to analyze all the principles, which enable the accumulation, migration and generation of petroleum.

Sedimentary basin:

- The basin is a part of the crust and it has a large areal extent, which is relatively well impounded and filled with sedimentary rocks of a large thickness (1-15km).

About 650 sedimentary basins can be found all over the world. Basins are classified as one from the aspect of exploration: mature, which are well explored and second which are not explored yet called frontier basins.

There can be several geological time periods in a given basin and the respective formations. Play is a zone or area of identical genetics where several crude oil and natural gas fields can be found.

Source rock: oil can be mostly found in sedimentary rocks rich in organic material.

2.5 Migration:

- Migration is the process of the oil and gas moving away from the source rock. This is a slow process i.e. perhaps a few kilometers over a period of millions of years. Migration is caused by burial, compaction, and increase in volume and separation of the source rock constituents.

There must be space 'porosity' within the rocks to allow for movement. In addition, there should be 'permeability' within the rocks to allow for flow.

Primary and secondary migration

Primary migration is the process of movement from source rock.

Secondary migration is movement to or within the reservoir entrapment.

Primary Migration:

Primary migration is the transportation of water, oil and gas out of the compacting sediments. For example: When source muds are first deposited they consisted of 70-80% water. What is left is solids such as clay materials, carbonates particles or fine grained silica.

As sediments build up to greater thickness in sedimentary basins, water is squeezed out by the Weight of the overlying sediments. Under normal hydrostatic pressure (0.445 psi/ft), the clays lose porosity and the pore diameters shrink as shown in the table below.

The primary migration of oil from source to reservoir is as follows

1. Water flows towards the lowest potential energy
2. Clay muds often have abnormal pressure because they are slow to release water
3. Avenues of migration during basing compaction are:

- Sandstone's
- Unconformities
- Fracture / Fault systems
- Biothermal reefs.

Secondary Migration:

In secondary migration, the oil droplets are moved about within the reservoir to from pools. Secondary migration can include a second step during which crustal movements of the earth shift towards the position of the pool within the reservoir rock

Cap rock:

In the petroleum industry, cap rock is generally referred to as any non-permeable formation that may trap oil, gas or water, preventing it from migrating to the surface. A relatively impermeable rock, commonly shale, anhydrite or salt, that forms a barrier or seal above and around reservoir rock so that fluids cannot migrate beyond the reservoir. It is often found atop a salt dome. The permeability of a cap rock capable of retaining fluids through geologic time is $\sim 10^{-6}$ - 10^{-8} Darcies.

2.6 Structure contour maps:

Structure maps are drawn basically for oil/gas bearing areas on the top and bottom of each prospective zone and OWC/GOC/GWC are marked. Faults pinch out etc are also shown on these maps.

Isopach and Isopay maps:

Isopach maps are drawn by considering total effective thickness of the zone.

Isopay maps are prepared by considering only effective thickness of sands where HC's are present. Both of these maps are prepared from the electro logs in already drilled wells. The isopach maps give the variation of sands from one direction to the other whereas isopay maps give only the area covered by oil or gas from which reserves are estimated.

Section maps:

The section maps are prepared by correlating of electro logs taken in different wells in various directions. Faults if any are also plotted. This gives clear picture of the faults position and variation of pay thickness in various directions.

Chapter 3: WELL LOGGING

3.1 Introduction:

When we speak of a log in the oil industry we mean "a recording against depth of any of the characteristics of the rock formations traversed by a measuring apparatus in the well-bore." sometimes referred to as "wire-line logs" or "well logs", are obtained by means of measuring equipment (logging tools) lowered on cable (wire line) into the well. Measurements are transmitted up the cable (which contains one or several conductors) to a surface laboratory or computer unit. The recording of this information on film or paper constitutes the well-log. Log data may also be recorded on magnetic tape. A large number of different logs may be run, each recording a different property of the rocks penetrated by the well.

Wire-line logging is performed after an interruption (or the termination) of drilling activity, and is thus distinguished from "drilling-logs" (of such things as drilling-rate, mud-loss, torque, etc.) and "mud-logs" (drilling mud salinity, pH, mud-weight, etc) obtained during drilling operations.

Determination of rock composition:

This is the geologist's first task. Interpretation of the well-logs will reveal both the mineralogy and proportions of the solid constituents of the rock (i.e. grains, matrix and cement), and the nature and proportions (porosity, saturations) of the interstitial fluids.

Log analysts distinguish only two categories of solid component in a rock—"matrix" and "shale". This classification is based on the sharply contrasting effects they have, not only on the logs themselves, but on the petrophysical properties of reservoir rocks (permeability, saturation, etc.). Shale is in certain cases treated in terms of two constituents, "clay" and "silt".

Wire-line Geophysical Well Log: Continuous recording of a geophysical parameter along a borehole.

Table 1: Common wire-line geophysical well measurements (Rider, 1996)

Measurement	Log Type	Parameter Measured
Mechanical	Caliper	Hole diameter
Spontaneous	Temperature	Borehole temperature
	Self-Potential (SP)	Spontaneous electrical currents
	Gamma Ray (GR)	Natural radioactivity
Induced	Resistivity	Resistance to electric current
	Induction	Conductivity of electric current
	Sonic	Velocity of sound propagation
	Density	Reaction to gamma ray bombardment
	Photoelectric	Reaction to gamma ray bombardment
	Neutron	Reaction to neutron bombardment

1. Spontaneous Potential and Gamma Ray

The SP and GR logs measures naturally occurring physical phenomena in in-situ rocks.

3.2 Spontaneous Potential

The SP log is a measurement of the natural potential difference or self potential between an electrode in the borehole and a reference electrode at the surface (problem with offshore wells, no ground). No artificial currents are applied.

Three factors are necessary to produce an SP current:

1. A conductive fluid in the borehole,
2. A porous and permeable bed surrounded by an impermeable formation, and
3. A difference in salinity (or pressure) between the borehole fluid and the formation fluid.

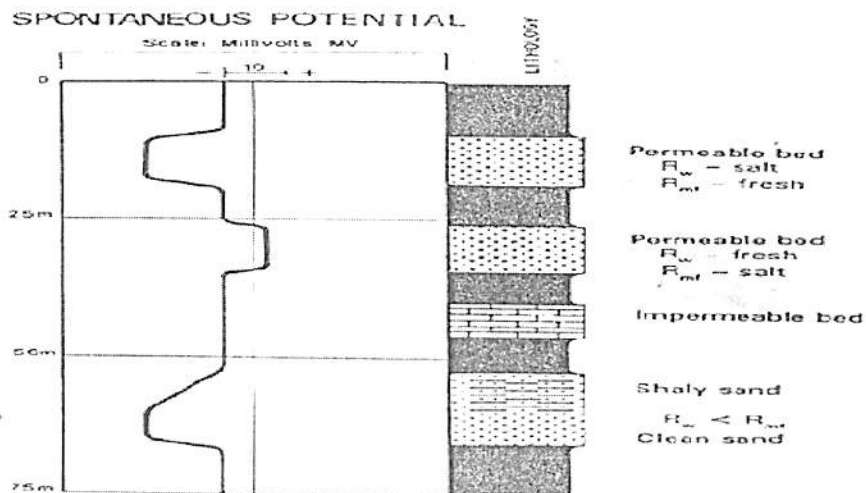

Figure 3(a): Idealized SP log.

Table 2: Principal uses of the SP log

	Used for	Knowing
Quantitative	Formation-water resistivity	Mud filtrate resistivity and formation temperature
	Shale volume	SSP (static SP) and shale line
Qualitative	Permeability indicator	Shale line
	Facies (shaliness)	Clay/Grain size relationships
	Correlation	

Bed Boundary Definition and Bed Resolution:

- Sharpness of a bed boundary depends on the shape and extent of the SPO current patterns. When there is considerable difference between mud and formation water resistivity, currents will spread widely and the SP will deflect slowly: definition is poor. When the resistivities are similar, boundaries are sharper. In general, SP should not be used to determine bed boundaries. If it has to be used, place the bed boundary at the point of maximum curve slope. (GR defines bed boundaries better.)

Shale Baseline and SSP

SP has no absolute values and thus treated quantitatively and qualitatively in terms of deflection, which is the amount the curve moves to the left or to the right of a defined zero. The definition of the SP zero, called shale baseline, is made on thick shale intervals where the SP curve does not move. All values are related to the shale baseline.

The theoretical maximum deflection of the SP opposite permeable beds is called the static SP or SSP. It represents the SP value that would be measured in an ideal case with the permeable bed isolated electrically. It is the maximum possible SP opposite a permeable, water-bearing formation with no shale. The SSP is used to calculate formation-water resistivity (R_w).

$$\text{Formation-water Resistivity } (R_w) = \frac{(R_{mf})e}{(R_w)e}$$

S (SP) = SP value: this should be the SSP

(R_{mf})e = equivalent mud filtrate resistivity: closely related to R_{mf}

(R_w)e = equivalent formation water resistivity: closely related to R_w

K = temperature-dependent coefficient

$$K = 61 + (0.133 \times T^{\circ}\text{F})$$

$$K = 65 + (0.24 \times T^{\circ}\text{C})$$

Shale Volume

$$V_{sh}(\%) = \left(1.0 - \frac{PSP}{SSP}\right) * 100$$

PSP (Pseudo-static SP) – the SP value in the water-bearing shaly sand zone read from the SP log.

SSP (Static SP) – the maximum SP value in a clean sand zone.

The formula simply assumes that the SP deflection between the shale base line (100% shale) and the static SP in clean sand (0% shale) is proportional to the shale volume. This is

qualitatively true but quantitatively there is no theoretical basis. Shale content from SP is subject to complications due to SP noise, R_w/R_{mf} contrast, HC content, and high salinity drilling fluids.

3.3 Gamma Ray

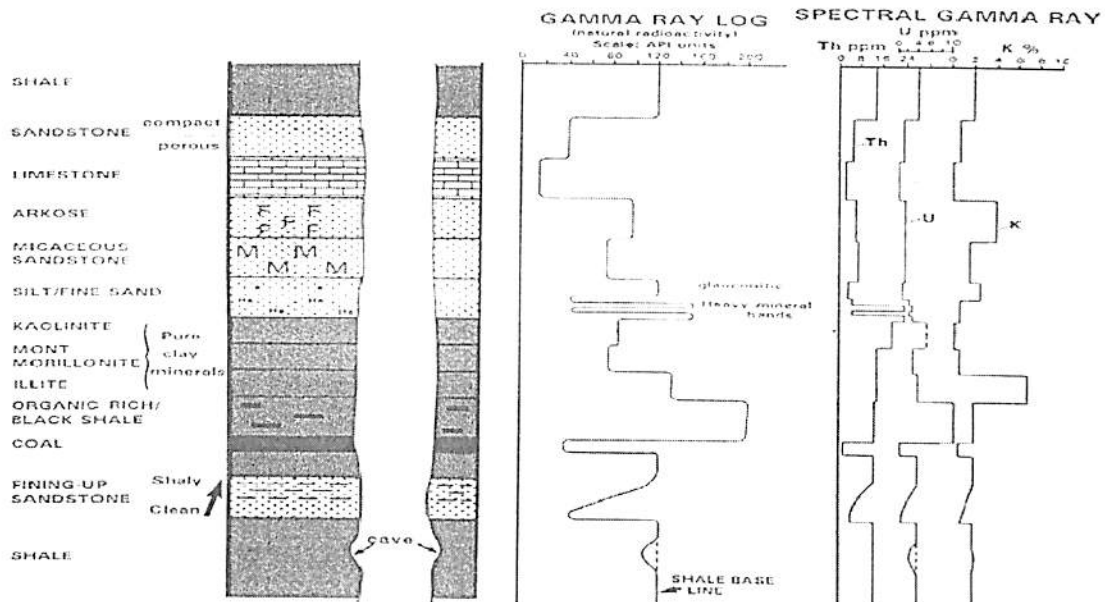

Figure 3(b) Idealized GR and SGR log.

$$Vsh = 0.33[2^{G-D_{GR}} - 1.0]$$

$$Vsh = 0.083[2^{I((3.7 \times I)_I GR)} - 1.0]$$

$$I_{GR} = \frac{GR_{iog} - GR_{min \square}}{GR_{max} - GR_{min \square}}$$

3. 4 Porosity Calculations – sonic, density, and neutron logs

3.4.1 Sonic log

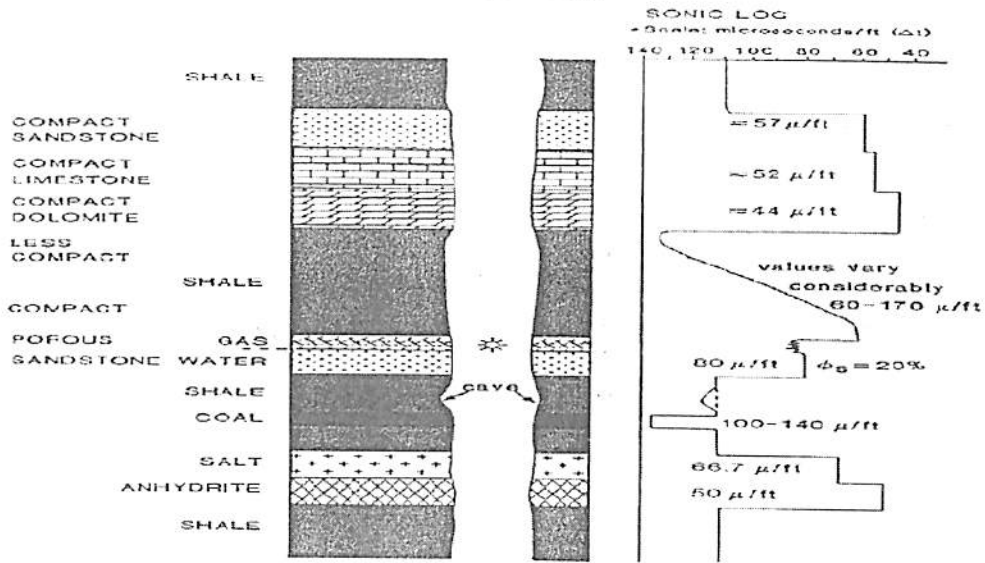

Figure 3(c) Idealized Sonic log.

Wyllie's Time Average Equation

$$\Delta t = \Phi \Delta t_f + (1 - \Phi) \Delta t_{ma}$$

Φ = porosity

Δt = log reading in microseconds/foot ($\mu\text{s}/\text{ft}$.)

Δt_f = transit time for the liquid filling the pore (usually 189 $\mu\text{s}/\text{ft}$.)

Δt_{ma} = transit time for the rock type (matrix) comprising the formation

$$\Phi = \frac{\Delta t - \Delta t_{ma}}{\Delta t_f - \Delta t_{ma}}$$

3.4.2 Density Log

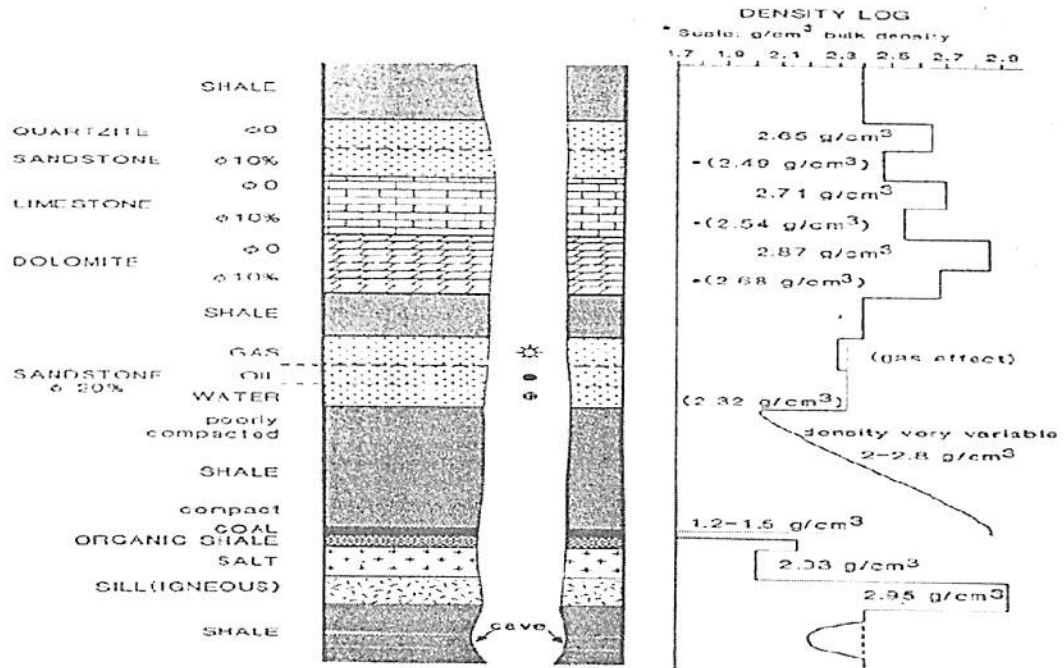

Figure 3(d) Idealized Density log.

$$\rho_b = \Phi \rho_f + (1 - \Phi) \rho_{ma}$$

Φ = porosity

ρ = log reading in microseconds/foot (μ s/ft.)

ρ_f = transit time for the liquid filling the pore (usually 189 μ s/ft.)

ρ_{ma} = transit time for the rock type (matrix) comprising the formation.

$$\Phi = \frac{\rho_{ma} - \rho_b}{\rho_{ma} - \rho_f}$$

3.4.3 Neutron

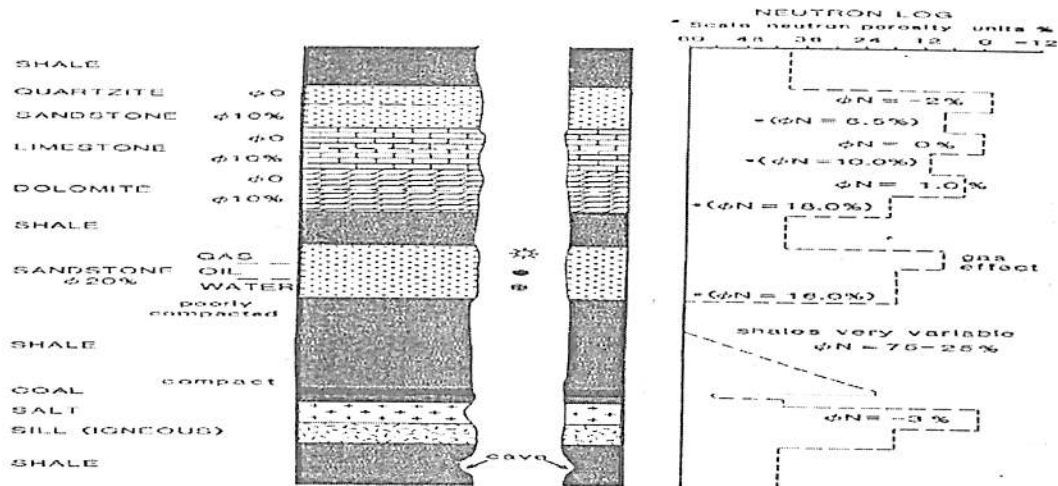

Figure 3(e) Idealized Neutron log.

Read directly from logs .May need matrix correction

$$\Phi = \frac{\phi_D + \phi_N}{2} \quad \text{if no light hydrocarbons}$$

$$\Phi = \frac{\sqrt{\phi_D + \phi_N}}{\sqrt{2}} \quad \text{if light hydrocarbons as present}$$

Water Saturation (Sw) Calculations

Archie's Equation

$$F = R_o/R_w$$

F = formation resistivity factor or simply formation factor

R_o = resistivity of rock when water saturation is 1(100% saturated)

R_w = resistivity of saturating water

$$F = \frac{a}{\phi^m}$$

Φ = porosity

a = cementation factor

m = cementation exponent

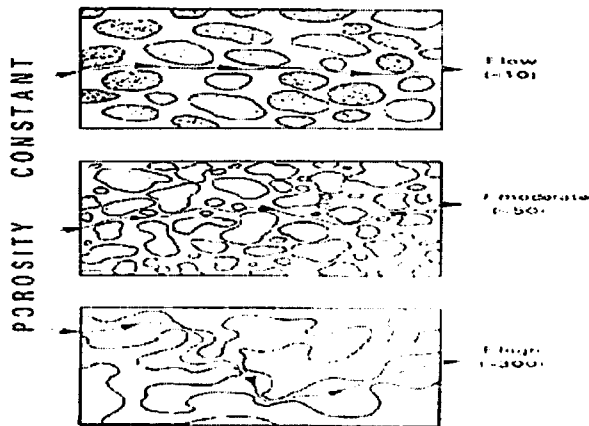

Figure 3(f). Schematic illustration of three formations with same porosity but different values of F (formation factor).

$$S_w^n = R_o/R_t$$

S_w = water saturation

R_t = resistivity of rock when $S_w < 1$

Combining the above equations gives Archie's equation, the most fundamental equation in well logging.

$$S_w = \frac{aR_w}{\phi^m R_t} = F \frac{R_w}{R_t}$$

Practical average Archie's Equation – general equation for finding water saturation.

$$S_w = \sqrt{\frac{0.62 \cdot R_w}{\phi^m \cdot R_t}}$$

Table 3: Nomenclature Used In the Archie's Equation

Symbol	Character	Derived from
Φ	Porosity	Porosity logs (sonic, neutron, density), cross-plots, etc.
$\frac{0.62}{\phi^{2.15}}$	F (formation factor)	Calculated using empirical formulae (e.g. Humble formula) and porosity as above
Rw	Formation water resistivity	SP or laboratory measurements of resistivities of formation water samples
Ro	Rock resistivity saturated 100% with water	$R_o = F \times R_w$ (can only be calculated, cannot be measured with logs)
Rt	True formation resistivity	Induction Logs and Laterologs (deep resistivity)
Sw	Water saturation of pores	$\frac{S_w \cdot \text{hydrocarbons}}{S_w \cdot 100\% \text{ water}} = \frac{R_o}{R_t}$

Chapter 4: RESERVOIR ROCK AND FLUID PROPERTIES

Introduction:

Hydrocarbon (oil and/or gas) occupy the pore spaces between the grains and/or fissures and cavities present in the rock. Majority of oil and gas reservoirs occur in the sedimentary rocks, which are good hydrocarbon collectors (sand, sandstone, conglomerate, fractured and cavernous limestones and dolomites). Because of difficult properties of rock controlling hydrocarbons, it is essential to know petrophysical characters of reservoirs, as well as producing formations, through which oil and/or gas enter the well and flow to the surface. Other rocks, such as clays, shales etc. are practically impervious and serve as cap rocks for hydrocarbon accumulations. The economic value of the hydrocarbon reservoirs is determined to a considerable extent by the physical properties of the reservoir rocks, reservoir fluids and also by the type and amount of the reservoir energy.

Core analysis is essentially a basic tool for obtaining direct data concerning the drilled reservoir rock. Core analysis data generated on rock samples recovered from a formation of interest play a important role in exploration programmes, well completion and workover operations, as well as in well and reservoir evaluations.

Core analysis provides direct measurement of some of the basic rock properties, which are needed to determine the total fluid content, distribution and flow behavior of the reservoir fluids or injected fluids. Importance of reliable and representative core data cannot be over-emphasized. These are basic data in evaluating oil/gas reservoirs. The interpretation of logging methods is established by correlation with core analysis data.

Rock Properties:

4.1 Saturation:

Fluid saturation is defined as the fraction of pore volume occupied by a particular fluid. Hence for reservoir fluids, mathematical expressions can be:

$$\text{Fluid saturation} = \frac{\text{TOTAL VOLUME OF THE FLUID}}{\text{PORE VOLUME}}$$

$$\text{Oil saturation, } S_o = \frac{\text{VOLUME OF OIL}}{\text{PORE VOLUME}}$$

$$\text{Gas saturation, } S_g = \frac{\text{VOLUME OF GAS}}{\text{PORE VOLUME}}$$

$$\text{Water Saturation, } S_w = \frac{\text{VOLUME OF WATER}}{\text{PORE VOLUME}}$$

Where,

S_o = oil saturation

S_g = gas saturation

S_w = water saturation

Thus, all saturation values are based on *pore volume* and not on the gross reservoir volume. The saturation of each individual phase ranges between zero to 100 percent. By definition, the sum of the saturations is 100%, therefore

$$S_g + S_o + S_w = 1.0$$

The fluids in most reservoirs are believed to have reached a state of equilibrium and, therefore, will have become separated according to their density, i.e., oil overlain by gas and underlain by water. In addition to the bottom (or edge) water, there will be connate water distributed throughout the oil and gas zones. The water in these zones will have been reduced to some irreducible minimum. The forces retaining the water in the oil and gas zones are referred to as *capillary forces* because they are important only in pore spaces of capillary size. Connate (interstitial) water saturation S_{wc} is important primarily because it reduces the amount of space available between oil and gas. It is generally not uniformly distributed throughout the reservoir but varies with permeability, lithology, and height above the free water table.

Critical oil saturation, S_{oc}

For the oil phase to flow, the saturation of the oil must exceed a certain value which is termed critical oil saturation. At this particular saturation, the oil remains in the pores and, for all practical purposes, will not flow.

Residual oil saturation, S_{or}

During the displacing process of the crude oil system from the porous media by water or gas injection (or encroachment) there will be some remaining oil left that is quantitatively characterized by a saturation value that is larger than the *critical oil saturation*. This saturation value is called the *residual oil saturation, S_{or}* . The term residual saturation is usually associated with the nonwetting phase when it is being displaced by a wetting phase.

· Movable oil saturation, S_{om}

Movable oil saturation S_{om} is another saturation of interest and is defined as the fraction of pore volume occupied by movable oil as expressed by the following equation:

$$S_{om} = 1 - S_{wc} - S_{oc}$$

Where,

S_{wc} = connate water saturation

S_{oc} = critical oil saturation

Critical gas saturation, S_{gc} : As the reservoir pressure declines below the bubble-point pressure, gas evolves from the oil phase and consequently the saturation of the gas increases as the reservoir pressure declines. The gas phase remains immobile until its saturation exceeds a certain saturation, called critical gas saturation, above which gas begins to move.

· Critical water saturation, S_{wc}

The critical water saturation, connate water saturation, and irreducible water saturation are extensively used interchangeably to define the maximum water saturation at which the water phase will remain immobile.

Average Saturation:

Proper averaging of saturation data requires that the saturation values be weighted by both the interval *thickness* h_i and interval *porosity* Φ . The average saturation of each reservoir fluid is calculated from the following equations:

$$S_o = \frac{\sum_{i=0}^n \Phi_i h_i S_{oi}}{\sum_{i=0}^n \Phi_i h_i}$$

$$S_g = \frac{\sum_{i=0}^n \Phi_i h_i S_{gi}}{\sum_{i=0}^n \Phi_i h_i}$$

$$S_w = \frac{\sum_{i=0}^n \Phi_i h_i S_{wi}}{\sum_{i=0}^n \Phi_i h_i}$$

4.2 Porosity: The porosity of a rock is a measure of the storage capacity (pore volume) that is capable of holding fluids. Quantitatively, the porosity is the ratio of the pore volume to the total volume (bulk volume).

$$\phi = \frac{\text{PORE VOLUME}}{\text{BULK VOLUME}}$$

As the sediments were deposited and the rocks were being formed during past geological times, some void spaces that developed became isolated from the other void spaces by excessive cementation. Thus, many of the void spaces are interconnected while some of the pore spaces are completely isolated. This leads to two distinct types of porosity, namely:

- Absolute porosity
- Effective porosity

Absolute porosity: The absolute porosity is defined as the ratio of the total pore space in the rock to that of the bulk volume. A rock may have considerable absolute porosity and yet have no conductivity to fluid for lack of poreinterconnection. The absolute porosity is generally expressed mathematically by the following relationships:

$$\phi_a = \frac{\text{TOTAL PORE VOLUME}}{\text{BULK VOLUME}} \quad \text{Or,}$$

$$\phi_a = \frac{\text{BULK VOLUME} - \text{GRAIN VOLUME}}{\text{BULK VOLUME}}$$

Effective porosity: The effective porosity is the percentage of *interconnected* pore space with respect to the bulk volume, or

$$\phi = \frac{\text{INTERCONNECTED PORE VOLUME}}{\text{BULK VOLUME}}$$

The effective porosity is the value that is used in all reservoir engineering calculations because it represents the interconnected pore space that contains the recoverable hydrocarbon fluids.

Porosity may be classified according to the mode of origin as original induced.

The *original* porosity is that developed in the deposition of the material, while *induced* porosity is that developed by some geologic process subsequent to deposition of the rock. The intergranular porosity of sandstones and the intercrystalline and oolitic porosity of some limestones typify original porosity. Induced porosity is typified by fracture development as found in shales and limestones and by the slugs or solution cavities commonly found in limestones. Rocks having original porosity are more uniform in their characteristics than those rocks in which a large part of the porosity is induced. For direct quantitative measurement of porosity, reliance must be placed on formation samples obtained by coring.

Since effective porosity is the porosity value of interest to the petroleum engineer, particular attention should be paid to the methods used to determine porosity. For example, if the porosity of a rock sample was determined by saturating the rock sample 100 percent with a fluid of known density and then determining, by weighing, the increased weight due to the saturating fluid, this would yield an effective porosity measurement because the saturating

fluid could enter only the interconnected pore spaces. On the other hand, if the rock sample were crushed with a mortar and pestle to determine the actual volume of the solids in the core sample, then an absolute porosity measurement would result because the identity of any isolated pores would be lost in the crushing process. One important application of the effective porosity is its use in determining the original hydrocarbon volume in place. Consider a reservoir with an areal extent of "A" acres and an average thickness of "h" feet. The total bulk volume of the reservoir can be determined from the following expressions:

$$\text{Bulk volume} = 43,560 Ah, \text{ ft}^3$$

$$\text{Or Bulk volume} = 7,758 Ah, \text{ bbl}$$

Where, A =areal extent, acres h =average thickness

The reservoir pore volume PV can then be determined by expressing the reservoir pore volume in cubic feet gives:

$$PV = 43,560 Ah\Phi, \text{ ft}^3$$

Expressing the reservoir pore volume in barrels gives:

$$PV = 7,758 Ah\Phi, \text{ bbl}$$

4.3 Permeability: Permeability is a property of the porous medium that measures the capacity and ability of the formation to transmit fluids. The rock permeability, k, is a very important rock property because it controls the directional movement and the flow rate of the reservoir fluids in the formation.

This rock characterization was first defined mathematically by Henry Darcy in 1856. In fact, the equation that defines permeability in terms of measurable quantities is called **Darcy's Law**.

Darcy developed a fluid flow equation that has since become one of the standard mathematical tools of the petroleum engineer. If a horizontal linear flow of an incompressible fluid is established through a core sample of length L and a cross-section of area A, then the governing fluid flow equation is defined as

$$v = -\frac{KdP}{\mu dL}$$

Where, v = apparent fluid flowing velocity, cm/sec

k =proportionality constant, or permeability, Darcys

μ = viscosity of the flowing fluid, cp

dp/dL = pressure drop per unit length, atm/cm

The velocity, v , is not the actual velocity of the flowing fluid but is the apparent velocity determined by dividing the flow rate by the cross-sectional area across which fluid is flowing. Substituting the relationship, q/A , in place of v and solving for q results in

$$q = -\frac{KA}{\mu} \frac{dP}{dL} \dots\dots\dots (1)$$

Where, q = flow rate through the porous medium, cm³/sec

A = cross-sectional area across which flow occurs, cm²

With a flow rate of one cubic centimeter per second across a cross-sectional area of one square centimeter with a fluid of one centipoise viscosity and a pressure gradient at one atmosphere per centimeter of length, it is obvious that k is unity. For the units described above, k has been arbitrarily assigned a unit called *Darcy* in honor of the man responsible for the development of the theory of flow through porous media. Thus, when all other parts of Equation (1) have values of unity, k has a value of one Darcy. One Darcy is a relatively high permeability as the permeabilities of most reservoir rocks are less than one Darcy. In order to avoid the use of fractions in describing permeability's, the term *millidarcy* is used. As the term indicates, one millidarcy, i.e., 1 md, is equal to one-thousandth of one Darcy or,

$$1 \text{ Darcy} = 1000 \text{ md}$$

The negative sign in Equation (1) is necessary as the pressure increases in one direction while the length increases in the opposite direction. Equation (1) can be integrated when the geometry of the system through which fluid flows is known. For the simple linear system shown

$$q \int_0^L dL = -\frac{KA}{\mu} \int_{p_2}^{p_1} dp$$

Integrating the above expression yields:

$$qL = \frac{KA}{\mu} (P_2 - P_1)$$

4.4 Wettability: Wettability is defined as the tendency of one fluid to spread on or adhere to a solid surface in the presence of other immiscible fluids. The concept of wettability is illustrated in Figure. Small *drops* of three liquids- mercury, oil, and water are placed on a clean glass plate. The three droplets are then observed from one side as illustrated in Figure. It is noted that the mercury retains a spherical shape, the oil droplet develops an approximately hemispherical shape, but the water tends to spread over the glass surface. The tendency of a liquid to spread over the surface of a solid is an indication of the *wetting* characteristics of the liquid for the solid. This spreading tendency can be expressed more conveniently by measuring the angle of contact at the *liquid-solid* surface. This angle, which is always measured through the liquid to the solid, is called the contact angle θ . The contact

angle θ has achieved significance as a measure of wettability. As shown in Figure, as the contact angle decreases, the wetting characteristics of the liquid increase. Complete wettability would be evidenced by a zero contact angle, and complete nonwetting would be evidenced by a contact angle of 180° . There have been various definitions of *intermediate* wettability but, in much of the published literature, contact angles of 60° to 90° will tend to repel the liquid. The wettability of reservoir rocks to the fluids is important in that the distribution of the fluids in the porous media is a function of wettability. Because of the attractive forces, the wetting phase tends to occupy the smaller pores of the rock and the nonwetting phase occupies the more open channels.

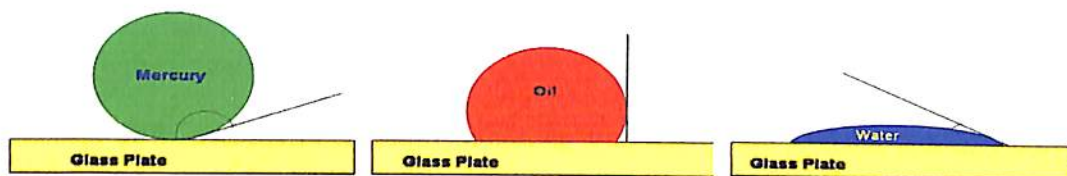

4.5 Capillary Pressure:

The coexistence of two or more immiscible fluids within the voids of a porous medium, such as a reservoir rock, gives rise to capillary forces. As interfacial tension exists on the boundary between two immiscible fluids in a pore space, the interface is curved and there is a pressure difference across the interface. The pressure difference is termed the capillary pressure.

When two immiscible fluids are in contact in the interstices of a porous medium, a discontinuity in pressure exists across the interface separating them. The difference in pressure is called capillary pressure (P_c).

$$P_c = P_{\text{non-wetting}} - P_{\text{wetting}}$$

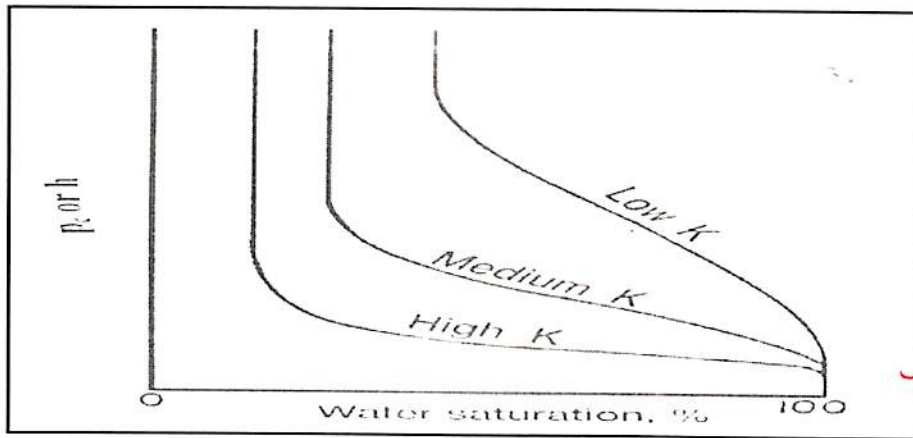

Figure 4(a) Variation of Capillary pressure with permeability (after Tarek Ahmed, Reservoir Engineering Handbook)

4.6 Surface and Interfacial tension: In dealing with multiphase systems, it is necessary to consider the effect of the forces at the interface when two immiscible fluids are in contact. When these two fluids are liquid and gas, the term *surface tension* is used to describe the forces acting on the interface. When the interface is between two liquids, the acting forces are called *interfacial tension*. The surface or interfacial tension has the units of force per unit of length, e.g., dynes/cm, and is usually denoted by the symbol σ .

4.7 Rock Compressibility: A reservoir thousands of feet underground is subjected to an overburden pressure caused by the weight of the overlying formations. Overburden pressures vary from area to area depending on factors such as depth, nature of the structure, consolidation of the formation, and possibly the geologic age and history of the rocks.

RESERVOIR-FLUID PROPERTIES:

To understand and predict the volumetric behavior of oil and gas reservoirs as a function of pressure, knowledge of the physical properties of reservoir fluids must be gained.

4.8 Crude Oil Gravity: The crude oil density is defined as the mass of a unit volume of the crude at a specified pressure and temperature. It is usually expressed in pounds per cubic foot. The specific gravity of a crude oil is defined as the ratio of the density of the oil to that of water.

4.9 Oil Formation Volume Factor: The oil formation volume factor, B_o , is defined as the ratio of the volume of oil (plus the gas in solution) at the prevailing reservoir temperature and pressure to the volume of oil at standard conditions. B_o is always greater than or equal to unity.

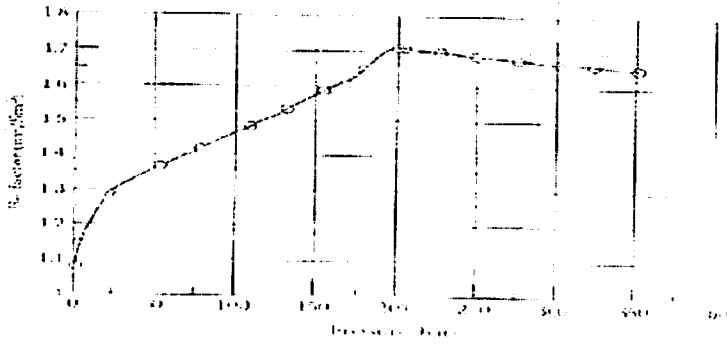

Figure 4(b) B_o as a function of pressure in differential liberation experiment. (Ref: Phase behavior of reservoir fluids by Karen Schou Pederson and Peter L. Christensen)

4.10 Crude Oil Viscosity:

Crude oil viscosity is an important physical property that controls and influences the flow of oil through porous media and pipes. The viscosity, in general, is defined as the internal resistance of the fluid to flow.

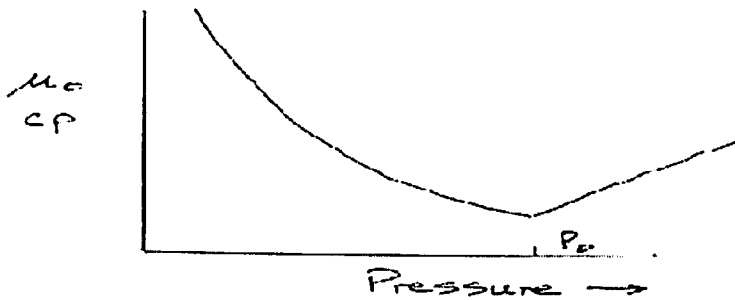

Figure 4(c) Viscosity as a function of Pressure

4.11 PVT Analysis Of Reservoir Fluid

PVT properties are the general term used to express the volumetric behavior of a reservoir fluid as a function of temperature and pressure. In order to maximize the production from oil or gas field, it is essential to have extensive knowledge about volumetric and phase changes of reservoir fluid, on its way from reservoir to refinery. Volumetric changes taking place in the reservoir, during passage of the well and in the processing plant can be studied by performing PVT experiments. Some important PVT properties measured in PVT experiments are as follows:

1. Constant Mass Expansion Experiment

The constant- mass or constant composition expansion experiment is performed for gas condensate and on oil mixtures. In this experiment fixed amount of a reservoir fluid is

transferred to a closed cell in which temperature is kept constant and volume is changed. A constant –mass-expansion experiment gives information about the saturation pressure at the reservoir temperature and about the relative volumetric amounts of gas and oil in the reservoir at various stages of

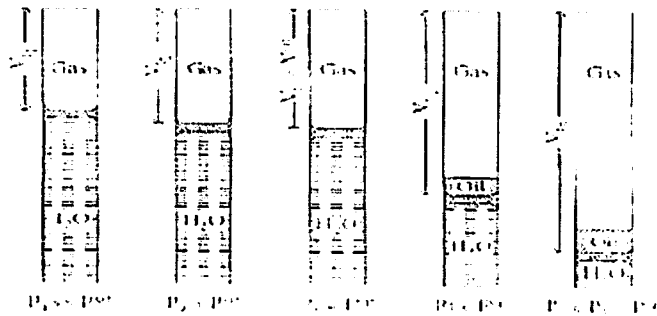

Figure 4(d): Schematic illustration of constant mass expansion experiment for gas condensate (Ref: Phase behavior of reservoir fluids by Karen Schou Pederson and Peter L. Christensen)

CME experiment is started at a pressure higher than saturation pressure i.e. Bubble point for oil mixture and Dew point for gas condensate. Various stages of experiment are as follows:-

- a) Initial mixture volume is recorded
- b) Mixture volume is increased stepwise
- c) At each stage measure cell volume and cell pressure
- d) When additional phase start to form, measure the cell volume (Saturation volume V_s) and saturation pressure.
- e) At each stage of experiment measure relative volume (ratio between actual volume and volume at saturation pressure). For gas condensate mixture, gs phase compressibility factor Z is recorded above saturation pressure , below saturation pressure liquid volume, of gas condensate is measured as percentage of mixture volume at the Dew point (*Liquid Dropout*)

$$\% \text{ Liquid dropout} = 100 * (V^{liq} / V^{sat})$$

$$V^{rel} = V^{tot} / V^{sat}$$

2. Constant Volume Depletion Experiment

The Constant-Volume depletion experiment is performed for gas condensate or volatile oil. It is started at saturation pressure. The cell is constructed in the same manner as for Constant-Mass experiment, but is equipped with valve at top.

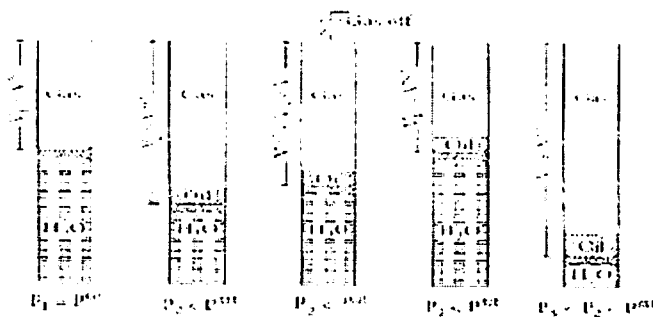

Figure 4(e) Schematic representation of constant volume depletion experiment (Ref: Phase behaviour of reservoir fluids by Karen Schou Pederson and Peter L. Christensen)

Constant-Volume depletion experiment is performed to gain knowledge about the changes with time in PVT properties of produced well streams from gas condensate and volatile oil reservoirs. In experiment, reservoir is seen as tank of fixed volume and at fixed temperature, during production pressure reduces. At saturation pressure, reservoir fluid split's into two phase. If all the production is from the gas zones, the mixture produced will have the same composition as removed from the cell. Gradually, gas becomes less enriched in heavy hydrocarbon. Various stages of experiment are as follows:-

- a) Fixed amount of reservoir fluid is kept in the cell at fixed temperature
- b) Start experiment at saturation pressure
- c) At saturation pressure , saturation volume is recorded
- d) At each stage reduce pressure by increasing volume, result in two phase formation.
- e) At each stage, mixture volume is subsequently reduced to saturation pressure by letting out the excess gas through valve, maintaining constant reduced pressure.
- f) Molar amount of gas depleted as percentage of gas initially in the cell and the liquid volume in the cell as percentage of saturation point volume are recorded.

3. Differential Liberation Experiment:

The Differential liberation experiment is performed for oil mixtures. In differential liberation experiment, reservoir fluid is transferred to a cell kept at fixed temperature. Differential liberation cell is equipped with a valve on top, allowing gas to be depleted during experiment.

Objective of differential liberation experiment is to generate information about volumetric changes taking place with the well stream when produced at standard conditions.

- a) Transfer fluid to a cell kept at fixed temperature.
- b) Start experiment above or at the reservoir pressure.
- c) Pressure is reduced at each stage and corresponding values of pressure and volume is recorded.
- d) At each pressure stage below saturation pressure, all gas is depleted through valve.

e) Experiment is continued to atmospheric pressure before cooling off the cell to 15 degree Celsius.

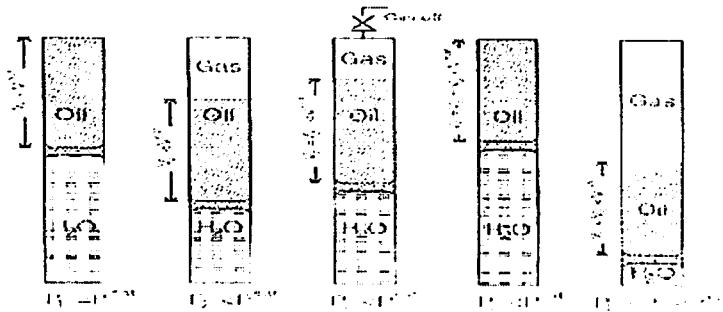

Figure 4(f) Schematic representation of differential liberation experiment. (Ref: Phase behaviour of reservoir fluids by Karen Schou Pederson and Peter L. Christensen)

4. Separator Test

Separator experiments are done for both oil and gas condensate. It can be two stage separator or three stage separator. The liquid from first stage is let into a second separator at lower pressure and temperature than first one which will result in gas liberation. The oil from the last separator at standard condition is often called stock tank oil and volume of this oil is called stock tank oil volume. The objective of a separator experiment is to get first idea about the relative volumetric amounts of gas and oil produced from particular petroleum reservoir.

Chapter 5: WELL TESTING AND IT'S INTERPRETATION

5.1 Role of Oil Well Tests and Information in Petroleum Industry:

Oil well test analysis is a branch of reservoir engineering. Information obtained from flow and pressure transient tests about in situ reservoir conditions are important to determining the productive capacity of a reservoir. Pressure transient analysis also yields estimates of the average reservoir pressure. The reservoir engineer must have sufficient information about the condition and characteristics of reservoir/well to adequately analyze reservoir performance and to forecast future production under various modes of operation. The production engineer must know the condition of production and injection wells to persuade the best possible performance from the reservoir. Pressures are the most valuable and useful data in reservoir engineering. Directly or indirectly, they enter into all phases of reservoir engineering calculations. Therefore accurate determination of reservoir parameters is very important. In general, oil well test analysis is conducted to meet the following objectives:

- To evaluate well condition and reservoir characterization;
- To obtain reservoir parameters for reservoir description;
- To determine whether all the drilled length of oil well is also a producing zone;
- To estimate skin factor or drilling- and completion-related damage to an oil well. Based upon the magnitude of the damage, a decision regarding well stimulation can be made

5.2 Productivity Well Testing: Productivity well testing, the simplest form of testing provides identification of productive fluids, the collection of representative samples and determination of reservoir deliverability. Reservoir deliverability is a key concern for commercial exploitation. Estimating a reservoir's productivity requires relating flow rates to drawdown pressures. This can be achieved by flowing the well at several flow rates (different choke sizes) and measuring the stabilised bottomhole pressure and temperature prior to changing the choke

The plot of flow data verses drawdown pressure is known as the inflow performance relationship (IPR). For monophasic oil conditions, the IPR is a straight line whose intersection with the vertical axis yields the static reservoir pressure. The inverse of the slope represents the productivity index of the well. The IPR is governed by properties of the rock-fluid system and near wellbore conditions.

Examples of IPR curves for low and high productivity are shown in Figure. The steeper line corresponds to poor productivity, which could be caused either by poor formation flow properties (low mobility-thickness product) or by damage caused while drilling or completing the well (high skin factor).

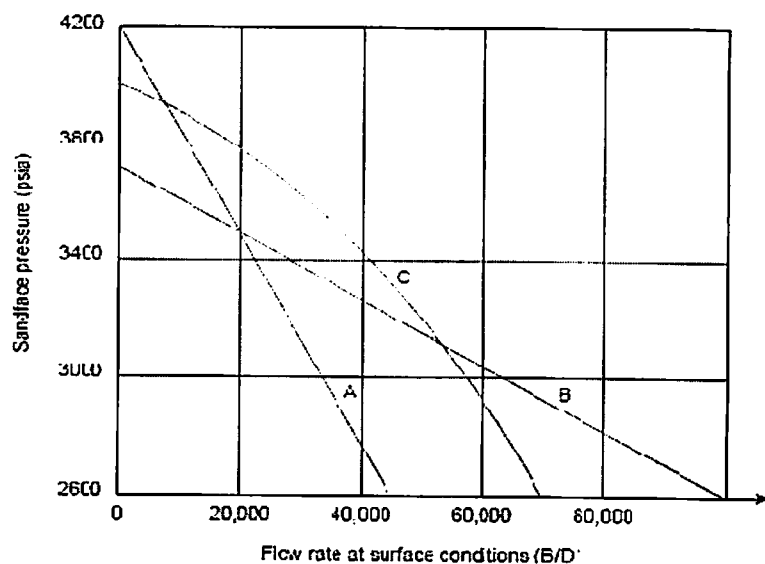

Figure 5(a): Typical inflow performance curves showing low (a) and high (b) productivity. For gas wells, IPR curves exhibit certain curvature (C) due to extra inertial and turbulent flow effects in the vicinity of the wellbore and changes of gas properties with pressure. Oil wells flowing below the bubble-point also display similar curvature, but these are due to changes in relative permeability created by variations in saturation distributions. (Ref: Introduction to well Testing, Bath, England March 1998, Schlumberger)

Reservoir oil flow analysis:

Types of Fluids:

The isothermal compressibility coefficient is essentially the controlling factor in identifying the type of the reservoir fluid. In general, reservoir fluids are classified into three groups:

- Incompressible fluids
- Slightly compressible fluids
- Compressible fluids

Flow Regimes: There are basically three types of flow regimes that must be recognized in order to describe the fluid flow behavior and reservoir pressure distribution as a function of time. There are three types of flow regimes:

- **Steady-state flow:** In steady-state flow, there is no change anywhere with time, i.e., the right hand sides of all the continuity and diffusivity equations are zero.
- **Unsteady-state flow:** Unsteady-state flow is a flow that occurs while the pressures and/or rate changes with time.

- **Pseudosteady-state flow:** When a reservoir is produced at a constant rate for a long enough period of time so that the entire drainage area of the reservoir is affected by the pressure disturbance, q constant change in pressure with time at all radii takes place. This constant pressure change results in parallel pressure distributions and corresponding constant rate distributions. This situation is called pseudo-steady-state flow

5.3 Pressure Buildup Test:

Pressure buildup analysis describes the build-up in wellbore pressure with time after a well has been shut in. One of the principal objectives of this analysis is to determine the static reservoir pressure without waiting weeks or months for the pressure in the entire reservoir to stabilize. Pressure buildup analysis describes the buildup in wellbore pressure with time after a well has been shut in. One of the principal objectives of this analysis is to determine the static reservoir pressure without waiting weeks or months for the pressure in the entire reservoir to stabilize. Slightly compressible, single-phase fluid with uniform properties so that the Ei function and its logarithmic approximation apply. Horner's approximation is applicable. Wellbore damage and stimulation is concentrated in a skin of zero thickness at the wellbore. Flow into the wellbore ceases immediately at shut-in. If a well is shut-in after it has produced at rate q for time t_p and the bottom-hole pressure p_{ws} is recorded at time At , then a plot of p_{ws} versus $\log (t_p + \Delta t)/\Delta t$ will give a straight line, which is represented by the following equation:

$$P_{ws} = - \frac{162.6q_o B_o \mu_o}{k h} \log \left[\frac{t_p + \Delta t}{\Delta t} \right]$$

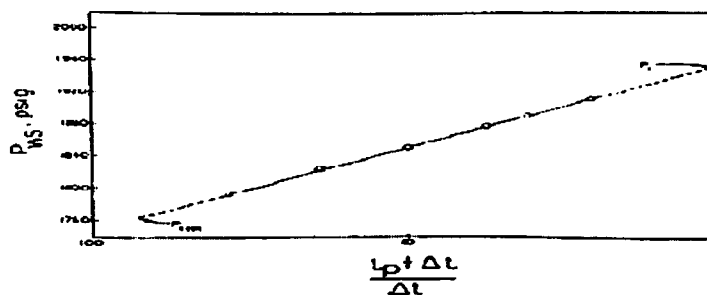

Figure 5(b). -Ideal pressure buildup test (Ref: Well testing manual by John Lee)

5.4 Skin:

If after drilling, completion, cementing and perforating, the overall pressure drop during production into the wellbore is identical to that for the ideal case, of a virgin, undamaged wellbore in an open-hole completion, the well is said to have a zero skin. More often than not the reservoir near the wellbore has been invaded by (typically water-based) drilling fluid, and has undergone changes in permeability, absolute and/or relative to the reservoir fluid. Some

of these changes are reversible during the 'clean-up' period, when the well is first put on production, but others are not.

$$S = \left[\frac{k}{k_s} - 1 \right] \ln \frac{r_s}{r_w}$$

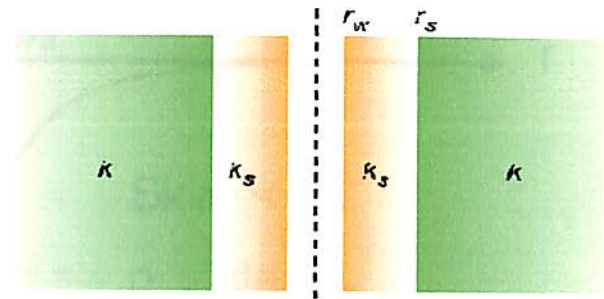

Figure 5(c): Skin open-hole (Ref: Introduction to well Testing, Bath, England March1998, Schlumberger)

The skin value S is dimensionless, and in most cases independent of flow rate, but the corresponding pressure drop Δp 's is rate-dependent. A positive skin represents near-wellbore 'damage', whereas a negative skin historically denotes 'stimulation', and physically means that there is a smaller pressure drop close to the wellbore than would be expected in the ideal case

If in the immediate vicinity close to the wellbore there is an additional pressure drop due to skin, the well is said to be damaged and $S > 0$:

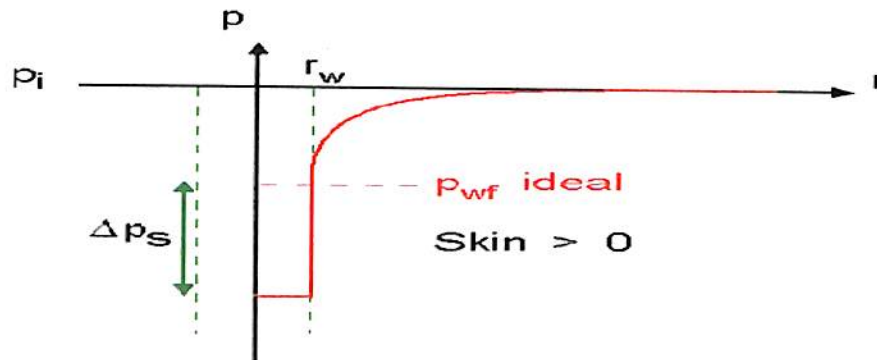

Figure 5(d): positive skin (Ref: Introduction to well Testing, Bath, England March1998, Schlumberger)

After stimulation, or a good TCP job, the pressure drop near the wellbore may be even less than in the 'ideal' case, so that $S < 0$:

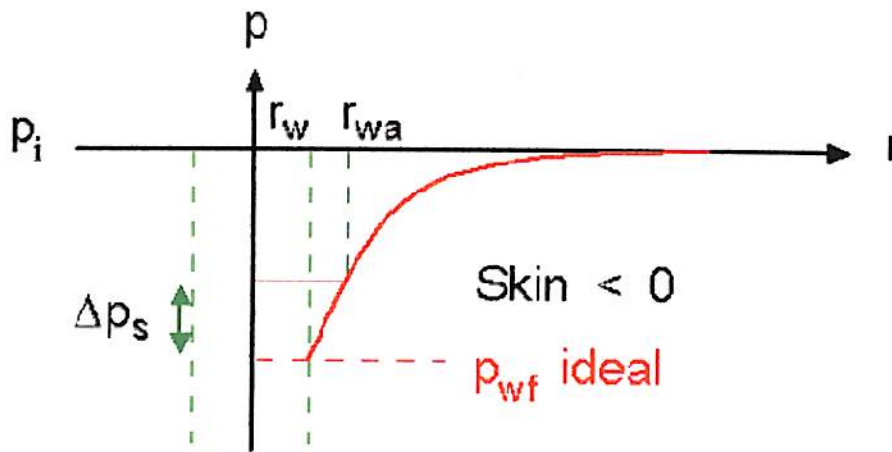

Figure 5(e): negative skin (Ref: Introduction to well Testing, Bath, England March 1998, Schlumberger)

5.5 Pressure Draw down Test:

A pressure drawdown test is simply a series of bottom-hole pressure measurements made during a period of flow at constant production rate. Usually the well is closed prior to the flow test for a period of time sufficient to allow the pressure to stabilize throughout the formation, i.e., to reach static pressure. A pressure drawdown test is conducted by producing a well, starting ideally with uniform pressure in the reservoir.

The objectives of a drawdown test usually estimate of permeability, skin factor and on occasion reservoir volume. These tests are practically applicable to applicable to (1) new

Wells, (2) wells that have been shut in sufficiently long to allow the pressure to stabilize and (3) wells in which loss of revenue incurred in a buildup test would be difficult to accept. Boundaries or important heterogeneities are I Exploratory wells are frequent candidates for drawdown tests.

Pressure-Time History for Constant-Rate

Drawdown Test flow history of an oil well and can be classified into three periods for analysis:

Transient or early flow period is usually used to analyze flow characteristics;

- Late transient period is more completed; and
- Semi-steady-state flow period is used in reservoir limit tests.

An idealized constant-rate drawdown test in an infinite-acting reservoir is modeled by the logarithmic approximation to the Ei-function solution:

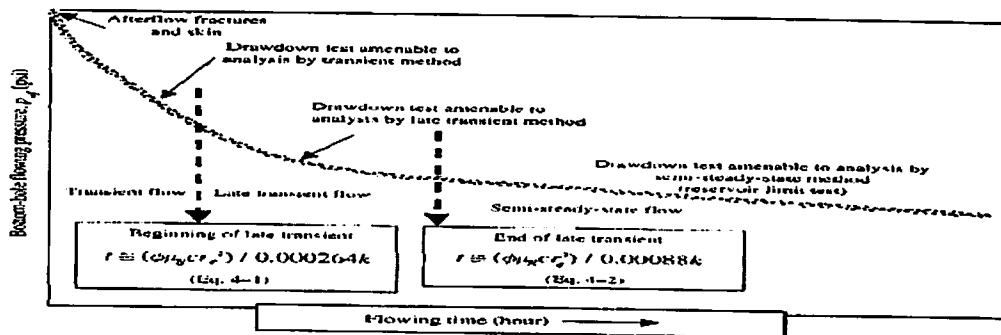

Figure 5 (f): Schematic pressure-time histories for a constant-rate drawdown test (after Odeh and Nabor, *J. Pet. Tech.*, Oct. 1966). (Ref: Oil Well Testing Handbook Amanat U. Chaudhry Advanced TWPSOM Petroleum Systems, Inc. Houston, Texas)

5.6 Type Curves:

Many type curves commonly are used to determine formation permeability and to characterize damage and stimulation of the tested well. Further, some are used to determine the beginning of the MTR for a Horner analysis. Most of these curves were generated by simulating constant-rate pressure drawdown (or injection) tests; however, most also can be applied to buildup (or falloff) tests if an equivalent shut-in time⁸ is used as the time variable on the graph. However, type curves are advantageous because they may allow least interpretation even when wellbore storage distorts most or all of the test data; in that case, conventional methods fail

Fundamentally, a type curve is a preplotted family of pressure drawdown curves. The most fundamental of these curves (Ramey's²) is a plot of dimensionless pressure change, p_D , vs. dimensionless time change, t_D . This curve, reproduced in Fig. has two parameters that distinguish the curves from one another: the skin factor s and a dimensionless wellbore storage constant, C_{SD} . For an infinite-acting reservoir, specification of C_{SD} and s uniquely determines the value of p_D at a given value of t_D .

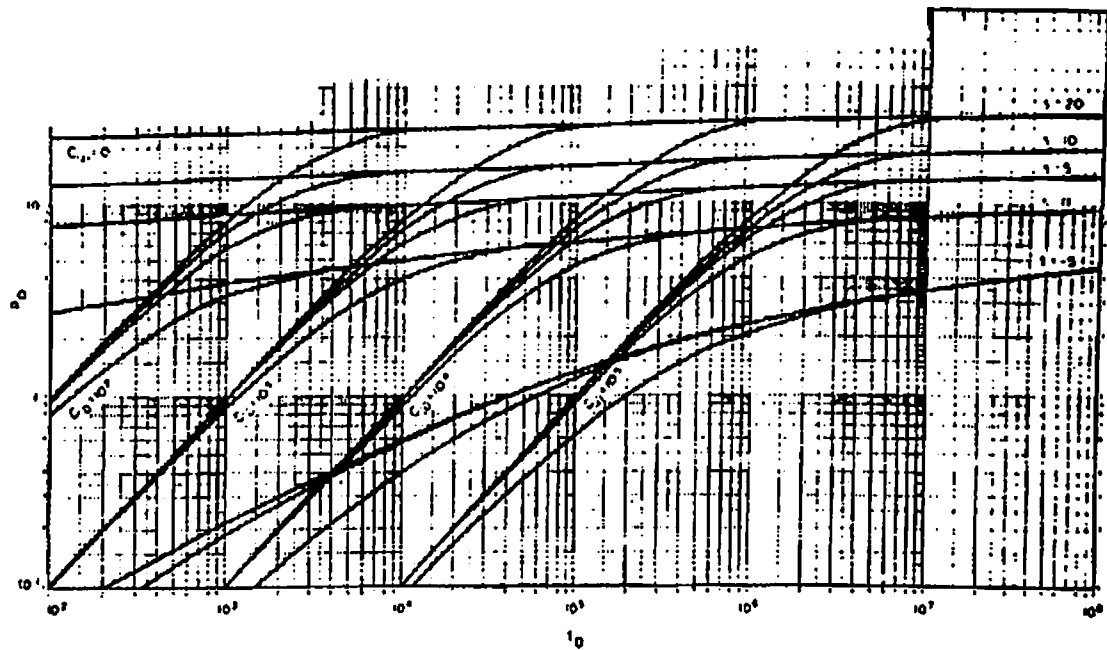

Figure 5(g) Type curves for constant production rate, infinite-acting reservoir (Ramey).

(Ref: John lee)

Thus, type curves are generated by obtaining solutions to the flow equations (e.g., the diffusivity equation) with specified initial and boundary conditions. Some of these solutions are analytical; others are based on finite-difference approximations generated by computer reservoir simulators.

5.7 Reservoir Heterogeneities:

Major Causes of Heterogeneities:

Heterogeneities may be caused because of:

- Post-depositional changes in reservoir lithology.
- Folding and faulting.
- Changes in fluid type or properties.
- Variations in rock and fluid properties from one location to another.
- Physical barriers, oil-water contacts, thickness changes, lithology changes.
- Different properties in each layer, etc.
- Man-made heterogeneities include changes near the wellbore from hydraulic fracturing, acidizing, or water injection.

Chapter 6: ESTIMATION OF RESERVES

6.1 Introduction

Estimating oil or gas reserves is one of the most important phases of the work of a petroleum engineer, since the solutions to the problems with which he deals usually depend on a comparison of the estimated cost in terms of dollars, with the anticipated result in terms of barrels of oil or cubic feet of gas. Specific engineering problems which require knowledge of recoverable oil and gas reserves and a projection of future rates are (1) the exploitation and development of an oil or gas reservoir; (2) the construction of gasoline plants, pipelines, and refineries; (3) the division of ownership in unitized projects; (4) the price to be paid in case of a sale or purchase of a producing property, and the magnitude of loan which it will support; (5) the proper depletion rate for the investment in producing properties; and (6) evaluation of the results of an exploration program.

Unfortunately, reliable reserve figures are most urgently needed during the early stages when only a minimal amount of information is available. The interest in the ultimate recovery from a producing property—aside from its use for accounting purposes—usually declines when the property approaches its economic limit, just at the time when the reliability of the estimates is at its best.

It should be emphasized that, as in all estimates, the accuracy of the results cannot be expected to exceed the limitations imposed by inaccuracies in the available basic data. The better and more complete the available data; the more reliable will be the end result. In cases where property values are involved, additional investment in acquiring good basic data during the early stages pays off later. With good basic data available, the engineer making the estimate naturally feels surer of his results and will be less inclined to the cautious conservatism which often creeps in when many of the basic parameters are based on guesswork only. Generally all possible approaches should be explored in making reserve estimates and all applicable methods used. In doing this, the experience and judgment of the evaluator are an intangible quality, which is of great importance.

The oil and gas reserve estimation methods can be grouped in to following categories:

- 1) Volumetric method ✓
- 2) Material balance method
- 3) Decline curve analysis
- 4) Reservoir simulation

VOLUMETRICS AND INITIAL HYDROCARBON VOLUME

The first step in a reservoir study is to accurately determine the initial hydrocarbon volume. This requires data which will allow us to calculate the size and geometry of the reservoir and the fluid volumes which the reservoir contains. In this section we will briefly look at how maps and cross-sections are used to describe the geometry of a reservoir and calculate the hydrocarbon volume in-place. Contour maps are commonly used to show reservoir geometry and the distribution of important reservoir parameters.

STRUCTURE MAPS

Structure maps show the geometric shape of a reservoir or formation. The maps may show the top or the bottom of a structure or reservoir unit. Examples of Top of structure maps are attached. These maps also show the positions of fluid Contacts in the reservoir. Structure maps are prepared by geologists. The data on which the maps are Drawn usually come from:

- (i) Well control,
- (ii) Geophysical data usually in the form of *time* maps, and
- (iii) Geological models of depositional and post-depositional events.

Gross thickness isopach maps show the total interval between the top and the base of the reservoir rock for each well. **Structure maps** on the top and on the base of the reservoir can provide data for the isopach map. Frequently, most of the wells are not drilled to the base of the reservoir so a base structure map cannot be drawn. In this case, the gross sand interval must be estimated from reservoir cross-sections based on logs from the well which penetrated the entire interval.

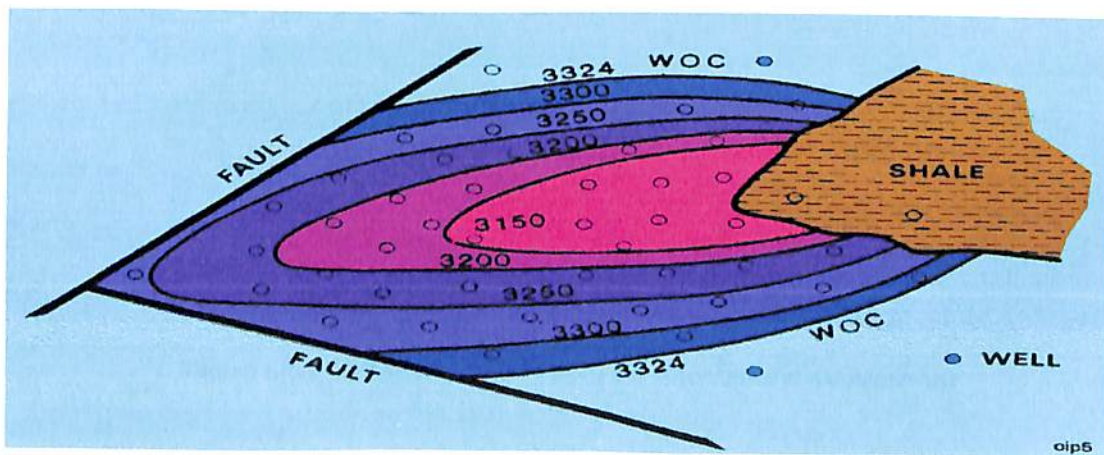

Figure 6(a): Top-of-structure map of a hydrocarbon reservoir

The gross pay isopach map for an oil reservoir is more descriptive of the hydrocarbon reservoir geometry than the gross thickness isopach.

ISOPACH MAPS

Isopach maps show the distribution and thickness of reservoir properties of interest. The contour lines connect points of equal vertical interval. Examples of common isopach maps are:

Gross oil thickness isopach map: contours gross pay - the depth of the top of the oil column minus the top of the bottom of the oil column.

Net oil thickness isopach map: contours net pay - gross pay minus nonreservoir intervals such as shales. Net oil isopach maps are commonly used to calculate volumes of hydrocarbons in-place.

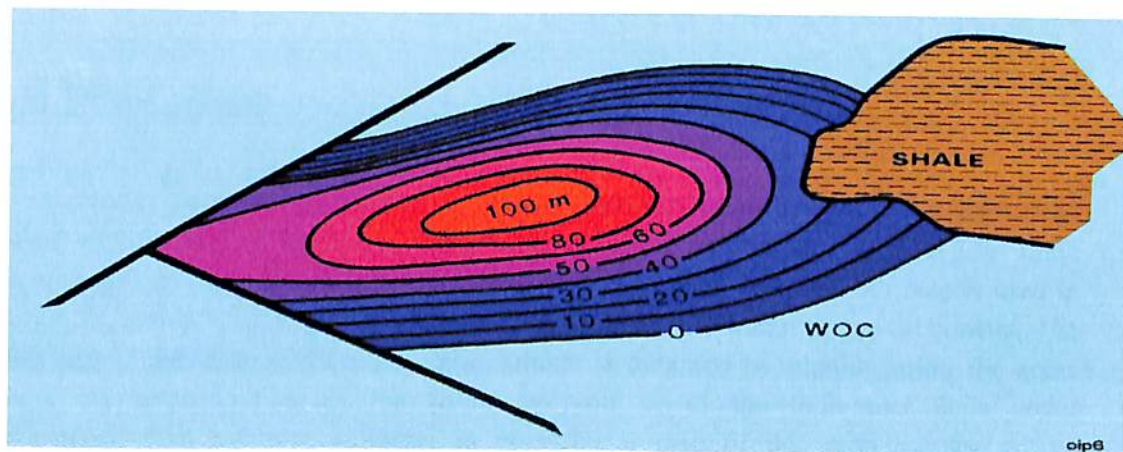

Figure 6(b): Net sand isopach map for a hydrocarbon reservoir

Other useful maps include:

Net-to-gross ratio maps: fraction of the total hydrocarbon interval which contributes to recovery.

Iso-porosity map: contours average porosity over net-pay portions of the desired formation.

Iso-water saturation map: contours average water saturation over net-pay portions of the desired formation.

6.2 Volumetric Method For Determining Original Oil-In-Place

The volumetric method entails determining the physical size of the reservoir, the pore volume within the rock matrix, and the fluid content within the void space. This provides an estimate of the hydrocarbons-in-place, from which ultimate recovery can be estimated by using an appropriate recovery factor. Each of the factors used in the calculation have inherent uncertainties that, when combined, cause significant uncertainties in the reserves estimate.

The standard cubic feet of gas in a reservoir with a gas pore volume of v_g cu ft is simply V_g/B_g , where B_g is expressed in units of cubic feet per standard cubic foot. As the gas volume factor B_g changes with pressure the gas in place also declines. The gas pore-volume V_g may also be changing, owing to water influx into the reservoir. The gas pore-volume is related to the bulk, or total, reservoir volume by the average porosity Φ and the average connate water S_w . The bulk reservoir volume V_b is commonly expressed in acre-feet, and the standard cubic feet of gas in place, G , is given by:

$$G = \frac{43,560 \phi(1 - S_w)V_b}{B_g}$$

The volumetric method uses subsurface and isopachous maps based on the data from electrical logs, cores, and drill-stem and production tests. The reservoir engineer uses these maps to determine the bulk productive volume of the reservoir. The contour map is used in preparing the isopachous maps when there is an oil-water, gas-water, or gas-oil contact. The contact line is the zero isopach line. The volume is obtained by planimetry of the areas between the isopach lines of the entire reservoir or of the individual units under consideration. The principal problems in preparing a map of this type are the proper interpretation of net sand thickness from the well-logs and the outlining of the productive area of the field as defined by the fluid contacts, faults, or permeability barriers on the subsurface contour map.

The bulk volume (V_b) between two successive contours is given by the *pyramidal formula*:

$$\Delta V_n = \frac{h}{3} (A_n + A_{n+1} + \sqrt{A_n A_{n+1}})$$

where,

ΔV_n = bulk volume between contours n and $n+1$.

A_n = the area enclosed by the lower contour.

A_{n+1} = the area enclosed by the upper contour.

h = the vertical height between the contours, or the contour interval.

The above equation is used to determine the volume between successive isopach lines, and the total volume is the sum of these separate volumes. The volume of a trapezoid is:

$$\Delta V_t = \frac{h}{2(A_n + A_{n+1})}$$

Or for a series of successive trapezoids:

$$V_b = \frac{h}{2} (A_0 + 2A_1 + 2A_2 + \dots + 2A_{n-1} + A_n) + t_{avg} A_n$$

A_0 is the area enclosed by the zero isopach line in acres; $A_1, A_2, A_3, \dots, A_n$ are the areas enclosed by successive isopach lines in acres; t_{avg} is the average thickness above the top or maximum thickness isopach line in feet; and h is the isopach interval as shown in the diagram below.

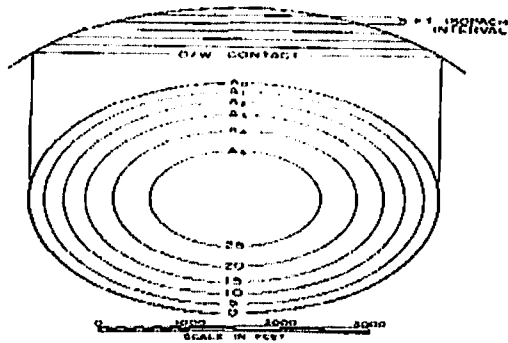

Figure 6(c): Cross-section and isopachous map of an idealized reservoir

A commonly adopted rule in unitization programs is that wherever the ratio of the areas of any two successive isopach maps is smaller than 0.5, the pyramidal formula is applied. Whenever the ratio of the areas of any two successive isopach lines is found to be greater than 0.5, the trapezoidal formula is used.

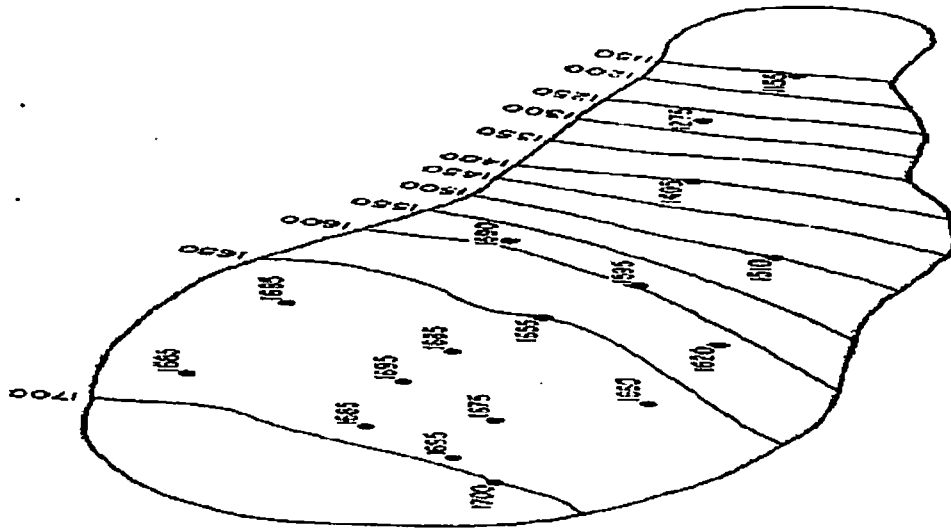

Figure-6(d): Reservoir pressure survey showing isobaric lines drawn from the measured bottom-hole pressures.

$$\text{Well average pressure} = \frac{\sum_{i=0}^n P_i}{n}$$

$$\text{Areal average pressure} = \frac{\sum_{i=0}^n F_i A_i}{\sum_{i=0}^n A_i}$$

$$\text{Volumetric average pressure} = \frac{\sum_{i=0}^n P_i A_i h_i}{\sum_{i=0}^n P_i h_i}$$

From the above equations average reservoir pressure can be calculated.

6.3 Material Balance Determination of Hydrocarbons In Place

One of the fundamental principles used in engineering is the Law of Conservation of Matter. The application of this law to petroleum reservoirs is known as the "material balance equation" which has proven to be an invaluable supplement to direct volumetric calculation of reservoir parameters. The material balance equation is being widely used today, aided by access to computers and the increasing knowledge base in the literature. The results from material

balance calculations are significant because they are largely independent of the factors that contribute to volumetric estimates. As databases for

Production, reservoir pressure, and fluid properties improve the usefulness of the material balance equation increases.

When oil, gas or water is removed from a reservoir, the pressure in the reservoir tends to fall, and the remaining fluids expand to fill the vacated space. The hydrocarbon system is also affected by fluids and energy sources that are in pressure communication with it. Examples of these include connected natural aquifers, nearby injection or production activities, and other oil or gas reservoirs.

The material balance is the application of the Law of Conservation of Matter to a petroleum reservoir during its depletion history. It is important for the reservoir engineer to understand the system at hand and apply the material balance realistically.

Simply stated, the material balance says that the initial mass, plus the mass added, less the mass removed, must equal the mass remaining in the system. In reservoir engineering usage, mass is often replaced by volume. Thus the bulk volume, plus fluid entry volumes, plus expansion, must equal the bulk volume remaining plus voidage. If the bulk volume is considered constant, then at reservoir pressure and temperature, expansion equals voidage.

The use of material balance by practicing reservoir engineers has recently fallen from favor with the development of reservoir simulation. This loss of knowledge and experience is unfortunate when the simplicity of material balance calculations is considered compared to reservoir simulation. Indeed, all the data required for a material balance analysis is collected for any reservoir simulation study. It is the experience of this reservoir engineer that if material balance is successful in characterizing the aquifer and initial hydrocarbons in place, that the time required for the history matching process in a reservoir simulation project may be shortened by an order of magnitude! Furthermore, if material balance is unsuccessful in those reservoirs that can be described by a tank model, problems with the data are indicated and any reservoir simulation is doomed to failure.

The material balance equation has been used extensively to determine initial fluids in place, calculate water influx, estimate fluid recovery, and predict reservoir pressures.

Material Balance Concept: This equation simply states that as the pressure in the reservoir falls, the oil, gas and water must be allowed to expand. The volume of this expansion in reservoir barrels, along with a reduction in pore volume and any fluid injection, must be equal to the total fluid production also expressed in reservoir barrels. Although not its most simple algebraic form, the oil GMBE can be written as follows allowing each term in the equation can be readily identified:

$$\begin{aligned}
& \overset{\text{Oil}}{\text{Expansion}} + \overset{\text{Gas Cap}}{\text{Expansion}} + \overset{\text{Water}}{\text{Expansion}} \\
& N (B_o - B_{oi}) + N m B_{oi} \frac{(B_g - B_{gi})}{B_{gi}} + (N B_{oi} + N m B_{oi}) c_w \Delta p S_w / (1-S_w) \\
& + \overset{\text{Formation}}{\text{Contraction}} + \overset{\text{Water}}{\text{Influx}} + \overset{\text{Water}}{\text{Injection}} + \overset{\text{Gas}}{\text{Injection}} \\
& + c_f \Delta p (N B_{oi} + N m B_{oi}) / (1-S_w) + W_e + W_I B_{wi} + G_I B_{gi} \\
& = \overset{\text{Oil \& Dissolved}}{\text{Gas Production}} + \overset{\text{Free Gas}}{\text{Production}} + \overset{\text{Water}}{\text{Production}} \\
& = N_p B_o + N_p (R_p - R_{sol}) B_g + W_p B_w
\end{aligned}$$

$$N = \frac{N_p [B_o + (R_p - R_{sol}) B_g] - (W_e - W_p B_w) - G_{inj} B_{gij} - W_{inj} B_{wi}}{(B_o - B_{oi}) + (R_{gi} - R_s) B_g + m B_{oi} \left[\frac{B_g}{B_{gi}} - 1 \right] + B_{oi} (1+m) \left[\frac{S_w c_v + c_f}{1-S_w} \right] \Delta p}$$

Similarly, the gas GMBE can also be written in a form that allows each term expressed in reservoir barrels to be readily identified:

$$\begin{aligned}
& \overset{\text{Gas}}{\text{Expansion}} + \overset{\text{Water}}{\text{Expansion}} + \overset{\text{Water}}{\text{Influx}} + \overset{\text{Formation}}{\text{Expansion}} \\
& G (B_g - B_{gi}) + G B_{gi} c_w \Delta p S_w / (1-S_w) + W_e + c_f \Delta p G B_{gi} / (1-S_w) \\
& = G_p B_g + W_p B_w \\
& = \overset{\text{Gas}}{\text{Production}} + \overset{\text{Water}}{\text{Production}}
\end{aligned}$$

Before deriving the material balance, it is convenient to denote certain terms by symbols for brevity.

P_i = Initial reservoir pressure, psi

p = Volumetric average reservoir pressure

Δp = Change in reservoir pressure = $p_i - p$, psi

p_b = Bubble point pressure, psi

N = Initial (original) oil in place, STB

N_p = Cumulative oil produced, STB

G_p = Cumulative gas produced, scf

W_p = Cumulative water produced, bbl

R_p = Cumulative gas-oil ratio, scf/STB

GOR = Instantaneous gas-oil ratio, scf/STB

R_{si} = Initial gas solubility, scf/STB

R_s = Gas solubility, scf/STB

B_{oi} = Initial oil formation volume factor, bbl/STB

B_o = Oil formation volume factor, bbl/STB

B_{gi} = Initial gas formation volume factor, bbl/scf

B_g = Gas formation volume factor, bbl/scf

W_{inj} = Cumulative water injected, STB

G_{inj} = Cumulative gas injected, scf

W_e = Cumulative water influx, bbl

m = Ratio of initial gas-cap-gas reservoir volume to initial reservoir oil volume, bbl/bbl

G = Initial gas-cap gas, scf

P.V = Pore volume, bbl

C_w = Water compressibility, psi⁻¹

C_f = Formation (rock) compressibility, psi⁻¹

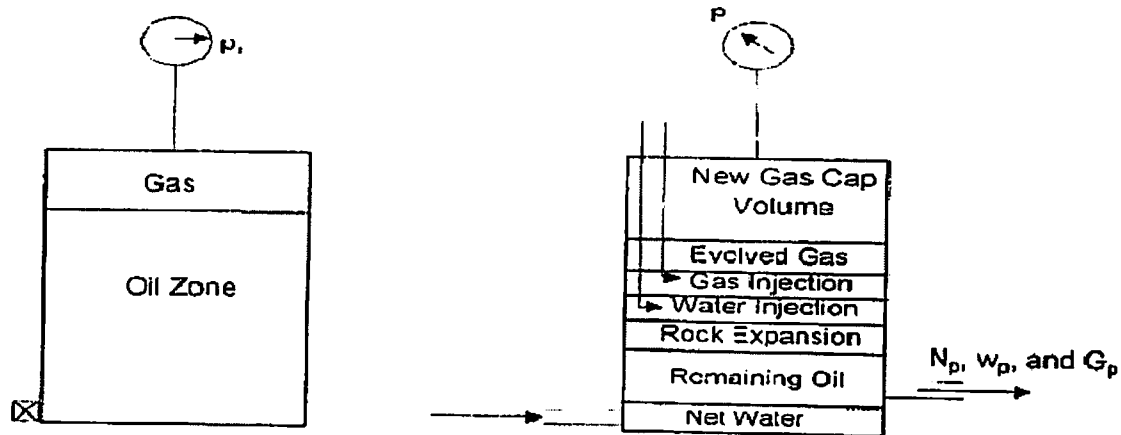

LIMITATIONS OF MATERIAL BALANCE METHODS:

The basis of the material balance is firm, and the equation can be made to encompass most of the factors relevant in hydrocarbon production. However, in practical application, several sources of errors limit the accuracy of material balance methods. The gravity of these errors varies with circumstances.

- 1 Thermodynamic equilibrium is not attained in actual field conditions.
- 2 PVT data is obtained using liberation processes that do not represent reservoir conditions.
- 3 Inappropriate average pressures are used.
- 4 There is uncertainty in the "m" ratio,
- 5 The production data used is inaccurate.

The amount of pressure decline covered by the production history is one of the best criteria in gauging potential errors. The material balance is a comparison of voidage to expansion and concentrates on evaluating fluid expansion. Large pressure declines produce large expansions, making inaccuracies in production volumes relatively less significant. Similarly, pressure errors are less critical with more pressure depletion. In general, a pressure decline of 10 percent of the original reservoir pressure is needed before the material balance becomes reliable. This critical depletion level is highly dependent upon the quality of the pressure, production and PVT data.

Pressure errors originate from several sources. Gauge and sonic survey errors can be compounded during processing and conversion to a common datum. True static pressures may be difficult to derive in low transmissibility pools with high viscosity fluids. Areally imbalanced withdrawal or injection may create regional pressure gradients in the pool. It is

important that such areal pressure variations be properly reflected in the averages applied to material balance equations. Volumetric averaging of measured values is the preferred technique. Multiple layers of differing permeability and severe lateral changes in permeability within the formation may complicate the gathering of representative pressures.

6.4 Decline Curve Analysis

Introduction:

Estimating reserves and predicting production in reservoirs has been a challenge for a long time. Many methods have been developed in the last several decades. One frequently-used technique is decline curve analysis approach. Most of the existing decline curve analysis techniques are Based on the empirical Arps equations: exponential, hyperbolic, and harmonic equations. It is difficult to foresee which equation the reservoir will follow. On the other hand, each approach has some disadvantages. For example, the exponential decline curve tends to underestimate reserves and production rates; the harmonic decline curve has a tendency to over predict the reservoir performance. In some cases, production decline data do not follow any model but cross over the entire set of curves. Many derivations were based on the assumption of single-phase oil flow in closed boundary systems. These solutions were only suitable for under saturated (single-phase) oil flow. However many oilfields are developed by water flooding. Therefore two-phase fluid flow instead of single-phase flow occurs. In this case, Lefkovits *et al.* derived the exponential decline form for gravity drainage reservoirs with a free surface by neglecting capillary pressure. Fetkovich *et al.* included gas-oil relative permeability effects on oil production for solution gas drive through pressure ratio term; this assumes that the oil relative permeability is a function of pressure. It is known that gas-oil relative permeability is a function of fluid saturation which depends on fluid/rock properties. In water flooding, oil relative permeability cannot be approximated as a function of pressure. The pressure during water flooding may increase, decrease, or remain unchanged. The oil production decline because of oil relative permeability reduction is associated with decrease in oil saturation instead of pressure in this case.

The decline curve is a basic tool for estimating remaining proved reserves, and can be applied once there is sufficient history to show a trend in a performance variable that is a continuous function of either time or cumulative production. Forecasts are made by extrapolating trends to an endpoint where production is expected to cease (i.e., an economic limit or a related parameter such as water-oil ratio). Such forecasts are particularly useful in the latter stages of depletion when trends are clearly evident and there is insufficient revenue to justify a more comprehensive analysis.

SOURCE AND ACCURACY OF PRODUCTION DATA:

It is worthwhile to review the source of the basic data used to prepare decline curves. Production accounting functions such as royalty payments, allocation of group production to individual wells, gas plant balances, and reports to regulatory agencies usually have a monthly reporting and reconciliation period. Daily records of hours of production, test rates, system pressure and other operating variables are kept to make these monthly reports, but they are often discarded or placed in dead files after a few months. The permanently accessible record of production and injection data usually consists of monthly totals for gas, oil, and water production (injection), operated hours, and wellhead pressure. Monthly totals

are usually converted to daily rates for graphing purposes because facility capacity, contract rates, and economic limits are usually expressed as daily rates. The frequency and quality of well tests are the most important factors affecting official production records. For gas wells, it is common practice to measure raw gas production for each well and to run annual deliverability tests.

The measured production helps to ensure reliable well-by-well cumulatives; however, the seasonal and variable demand for gas can result in highly variable rates, and this tends to complicate decline analyses. For oil wells, it is common practice to measure group production, and test individual wells monthly. The day-to-day demand for oil is less affected by markets, and many oil wells are produced at capacity, which tends to simplify decline analyses.

The least complex production facility is a single well served by a single-well battery. In such a facility, there is no doubt about the source of the production. The measurement accuracy will also be reliable if the facility is properly sized. Among the most complex facilities are central treating facilities that serve several multi-well satellite batteries equipped with three-phase test separators and operating at high pressure. In this case, the total (group) production of oil, gas, and water is allocated to individual wells on the basis of their operated hours and test rates. The accuracy of this allocation depends upon the frequency of well testing and the variation of oil, gas, and water rates among wells. A good indication of the allocation accuracy is given by the quotient of theoretical production and measured production for each fluid (e.g., oil, gas, and water).

Theoretical production is the piece-wise sum of the product of test rate and time interval. These quotients (called proration or allocation factors) are usually considered to be acceptable if they are in the range of 0.95 to 1.05. It should be noted that errors in test rates or producing hours will cause misallocations among wells and pools. Errors in gas-oil and water-oil ratios can be somewhat larger because the allocation factor for each fluid may differ (e.g., an oil allocation factor less than 1.0 and a water allocation factor greater than 1.0). Thus, gas-oil ratio and water-oil ratio curves often show more "noise" than their corresponding rate curves.

Table 4: Decline curve equations

	Type of decline		
	Exponential	hyperbolic	harmonic
Characteristics	decline is constant	decline varies with Instantaneous Rate raised to power "b."	decline is directly proportional to the Instantaneous rate.
Exponent	b=0	b≠0, b≠1.0	b=1.0
Rate-time Relationship	$q = q_i e^{-n_i t}$	$q = q_i ((1 + b a_i t))^{-\frac{1}{b}}$	$q = q_i ((1 + a_i t))^{-1}$

Rate-cumulative relationship.	$N_p = \frac{(q_i - q)}{a_i}$	$N_p = \frac{q_i^b}{(1-b)a_i} (q_i^{1-b} - q^{1-b})$	$N_p = \frac{q_i}{a_i} \ln \frac{q_i}{q}$
Dimensionless Time	$u_i = \ln \left(\frac{q_i}{q} \right)$	$a_i t = \frac{\left(\frac{q_i}{q} \right)^b - 1}{b}$	$u_i t = \left(\frac{q_i}{q} \right) - 1$
Dimensionless production	$\frac{N_p}{q_i t} = \frac{1 - \left(\frac{q_i}{q} \right)^{-1}}{\ln \left(\frac{q_i}{q} \right)}$	$\frac{N_p}{q_i t} = \frac{1 - \left(\frac{q_i}{q} \right)^{b-1}}{\left(\frac{q_i}{q} \right)^b - 1} \left(\frac{b}{b-1} \right)$	$\frac{N_p}{q_i t} = \frac{\ln \left(\frac{q_i}{q} \right)}{\left(\frac{q_i}{q} \right) - 1}$

Where, a = decline as a fraction of producing rate (slope of line)

a_i = initial decline rate

b = decline exponent

e = natural logarithm base 2.71828

N = cumulative production

q = producing rate at time (t)

q_i = producing rate at the beginning of the decline

t = time.

DECLINE CURVE METHODS FOR A GROUP OF WELLS

Estimating the reserves for a group of wells could be an onerous task if a decline analysis were performed for each well. Consequently, it is common practice to perform one decline analysis for the aggregated production from all the wells in a lease or pool. While this is common practice, it is not as reliable as one might assume. When the production from a group of wells is aggregated (summed), only the total is available for plotting, and much of the raw data is omitted from the analysis. Sometimes the average-well rate is plotted to make the analysis appear more like that for a single well. Another major difficulty is that the economic limit is not clearly defined for aggregated production. This difficulty also makes forecasts hazardous because some of the wells will be abandoned during the forecast and will no longer be contributing to the aggregate. Clearly, the theoretical base for aggregated production is not as solid as that for single wells.

Despite the foregoing problems, decline curve analysis can be successfully applied to aggregated production. For example, if there is a wide variation in rates, the analysis can be improved by splitting the wells into a few groups having similar characteristics (e.g., rates, water cuts, remaining life, well spacing, gas-oil ratios). By making sub-groups of wells with

similar remaining lives, an economic limit can be applied with more confidence. To establish a reliable decline for tight gas pools, the wells should be grouped on the basis of their on-production date and initial production rate. In general, aggregate rate vs. cumulative curves exhibit decline trends which are easier to interpret (i.e., better defined) than those for aggregate rate vs. time curves.

6.5 Reservoir Simulation

OBJECTIVE: To predict the future performance of a reservoir and optimize recovery and value of hydrocarbons. The simulator is the point of contact between disciplines. It serves as a filter that selects from among all of the proposed descriptions of the reservoir. The simulator is not influenced by hand-waving arguments or presentation style. It provides an objective appraisal of each hypothesis. One of the most important tasks of the modeler is to achieve consensus in support of a reservoir representation. This task is made more complex when available field performance data can be matched by more than one reservoir model. The non-uniqueness of the model is discussed in greater detail throughout the text. It means that there is more than one way to perceive and represent available data.

CLASSICAL METHODS

The reservoir is treated as homogeneous with average properties. These methods cannot adequately account for variations in space, time or operations.

NUMERICAL MODELS

These models can account for variations in reservoir properties, both in space and time. The fundamental flow equations can be applied to sub-sections of the reservoir, each of which is assumed to have homogeneous properties.

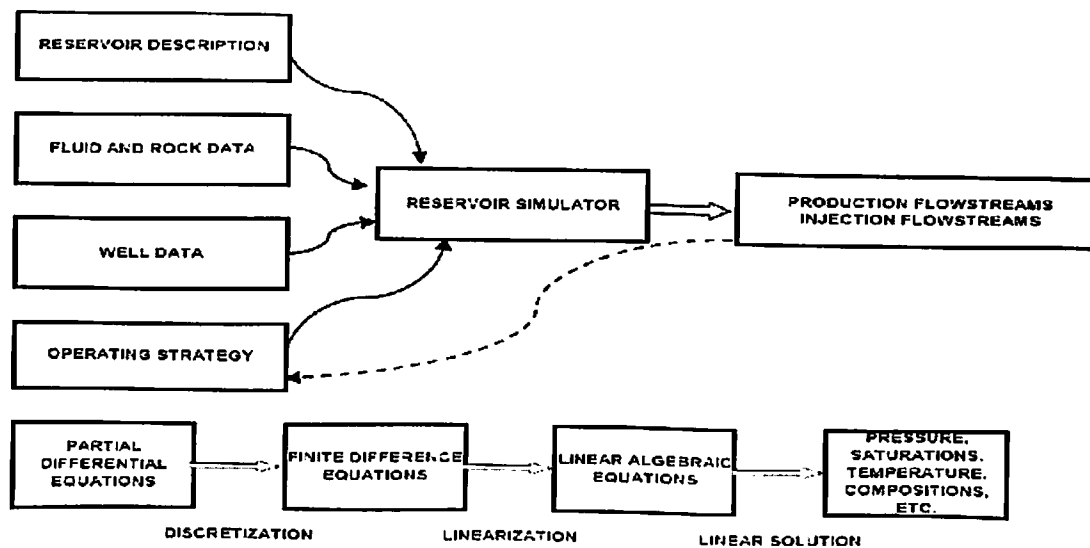

Figure 5(e): SIMULATOR

TYPES OF DATA TO VALIDATE

- Seismic Interpretation
- Regional Geology
- Sedimentology
- Outcrop Surveys
- Geostatistics
- Petrophysical Studies
- Core Analysis
- Relative Permeability / Cap Pressure
- SCAL
- SEM Cross Sections
- PVT Data
- Completion Data
- O/W/G Production / Injection Data
- Pressure Transient Tests
- RFT Data
- Reservoir Tracer Tests
- Spinner Surveys
- Observation Well Data
- Well Workover Response
- Material Balance Calculations
- Decline Curve Analysis

6.6 Oil Reservoirs:

Depending upon initial reservoir pressure p_i , oil reservoirs can be sub-classified into the following categories:

1. Undersaturated oil reservoir. If the initial reservoir pressure p_i is greater than the bubble-point pressure p_b of the reservoir fluid, the reservoir is labeled an undersaturated oil reservoir.
2. Saturated oil reservoir. When the initial reservoir pressure is equal to the bubble-point pressure of the reservoir fluid, the reservoir is called a saturated oil reservoir.
3. Gas-cap reservoir. If the initial reservoir pressure is below the bubblepoint pressure of the reservoir fluid, the reservoir is termed a gas-cap or two-phase reservoir, in which the gas or vapor phase is underlain by an oil phase. The appropriate quality line gives the ratio of the gas-cap volume to reservoir oil volume. Crude oils cover a wide range in physical properties and chemical compositions, and it is often important to be able to group them into broad categories of related oils. In general, crude oils are commonly classified into the following types:
 - Ordinary black oil
 - Low-shrinkage crude oil

- High-shrinkage (volatile) crude oil
- Near-critical crude oil

6.7 Primary Recovery Mechanisms:

For a proper understanding of reservoir behavior and predicting future performance, it is necessary to have knowledge of the driving mechanisms that control the behavior of fluids. Within reservoirs, the overall performance of oil reservoirs is largely determined by the nature of the energy, i.e., driving mechanism, available for moving the oil to the wellbore. There are basically six driving mechanisms that provide the natural energy necessary for oil recovery:

- Rock and liquid expansion drive
- Depletion drive
- Gas cap drive
- Water drive
- Gravity drainage drive
- Combination drive

Chapter 7: PETRO ECONOMICS

7.1 Cash Flow Analysis:

In any industry, accurate analysis of cash flow is an essential part of investment decision-making and optimum capital budgeting. Like all resource-based industries, the oil and gas industry depends on such analysis to quantify its resource base; remaining reserves are actually defined in the context of economics. Methodology for cash flow analysis in the energy industry is consistent with the general principles of business finance.

7.2 Mineral Rights Ownership:

Participants in the oil and gas industry lease the right to develop the minerals from the holders of the mineral rights. A number of different forms of property interest evolve from the leasing of these rights, with differences that are typically based on the sharing of risk and the requirement to provide development capital.

- **Mineral Interest:** Subsurface mineral rights are usually separate from surface rights. Ownership may be held privately, in which case it is known as a freehold interest, or by the government, in which case it is known as a Crown interest.

Royalty Interest: When a property is leased, the interest retained by the mineral rights holder is known as royalty interest. Freehold royalty interest would be contractually defined. Crown royalty interest is defined in legislation. The interest participant shares in the revenues, but has no obligation to fund development. **Overriding Royalty Interest.** This is an economic interest that is retained by a lessee when property rights are "farmed out" to another party. If the original lessee retains the economic interest without obligation to contribute to development costs, it is called a "gross overriding royalty" (GORR). If the original lessee allows the lessor to deduct certain defined expenses before paying royalty, it is called a "net overriding royalty" (NORR).

Production Payment Interest: This is similar to an overriding royalty but would typically be limited to either a production amount or quantity, or to a certain time.

- **Working Interest:** This is the most commonly held interest. The holder receives the net benefits after the previously mentioned interests are realized and is responsible for development costs.

Typically, there is more than one working interest owner. These owners would normally develop a property under the terms of a joint venture agreement which designates one of the owners as Operator. This arrangement is not usually considered a partnership as all the working interest owners are free to take their own production and dispose of it on their own terms. Whether the business arrangement is a joint venture or a partnership can be significant from the perspective of calculating income tax.

Carried Interest: This results when one party "carries" the development costs of another party. Working interests of the carried party would differ before and after payout of the carry amount. When the party has opted out of a development under an existing agreement, it will

likely have to wait until an additional "penalty" amount has been earned by the other parties before reverting to a working interest position.

Net Profits Interest: The net profits referred to will be calculated according to a contracted accounting procedure. In this case, the holder has no obligation to share development costs.

Pooling and Unitization: These terms refer to arrangements made, voluntarily or in accordance with government regulation, to jointly develop a resource property. Pooling generally refers to agreements within a drilling or production spacing unit, these typically being one quarter section for oil and one section for gas. Unitization normally has a broader context and would address a development that extends beyond the standard spacing units.

Individual participants can also undertake different conventional business arrangements such as joint ventures and partnerships. These structures also have tax implications that must be addressed.

7.3 Principal Sources And Uses Of Cash

Production Revenue: Custody transfer of product usually takes place at the lease boundary where the product is metered. Gross revenues are then the product of quantities sold and prices received.

It is important to differentiate between production revenue and processing revenue as the income tax treatment for these two items is different. In broad terms, production of crude oil stops at the exit of the battery while production of gas stops at the downstream end of the inlet separator of a gas plant. Revenue Canada uses the gas cost allowance calculation, from provincial Crown royalty calculations, as the basis for determining production vs. processing revenue for tax purposes.

Crude oil prices are typically posted by the buyer of the oil on a volume basis. The price is at a specific location, either in the field or at the refinery gate, and transportation tariffs must be deducted to bring the price to the wellhead. Future projections of price can be based on any number of approaches, ranging from a function of inflation to models that incorporate anticipated international supply and demand.

Processing Fees: In most cases, production will require some treatment prior to sale (in a few cases, production is sold as is at the wellhead). Oil typically requires removal of dissolved gas and produced water. Natural gas may require removal of water, heavier hydrocarbons, hydrogen sulphide, and carbon dioxide.

If the producing company has its own treatment facilities, associated capital costs and ongoing operating costs will have been recognized in the economic evaluation of the property. If the producing Company does not have the necessary facilities, it will have to incur an expense by paying another party to provide them.

Operating Costs: Field costs are typically some combination of a fixed cost, a unit cost per volume produced, and a monthly well cost. Disposal of produced water will sometimes involve off-lease disposal and an associated cost which can be based on the volume of water handled or can be a fixed fee per haul.

Facility operating costs are generally considered to be a combination of fixed and variable costs. When facility ownership is shared, operating costs are usually apportioned on the basis of throughput or contracted commitments.

Capital Costs: One of the more significant things to consider about a capital expenditure is the tax treatment of its components.

Another consideration is funding. If a company can not finance its capital requirements from cash flow, it has to consider other sources, and the risk associated with the planned development can affect both the source and cost of this funding. When debt financing is contemplated, the development may not on its own qualify for the balance of needed funds, and additional security or additional equity may be required. Either alternative could restrict the company's options on further development.

Site Restoration and Reclamation: This aspect of oil and gas operations has recently been receiving much more attention, and costs for decommissioning of facilities and reclamation and restoration of the wellsites should be included in cash flow analysis. While these costs may be accrued on an annual basis for accounting purposes, they are not actually incurred until the end of the economic life of the producing property. (Quite apart from facility decommissioning and wellsite reclamation and restoration costs, there may be ongoing operating costs to satisfy regulatory requirements.)

Well abandonment costs can be estimated on the basis of published regulations. Decommissioning and site restoration costs depend in part on the final condition of the site and the regulations in effect at the time. As such they are more difficult to estimate.

General and Administrative: Commonly referred to as G&A, these are the costs a company incurs in other than the direct operation of its properties, such as at a district or head office, and they must be recognized at some level in cash flow analysis.

If any G&A costs are allocated to a property that is less than 100 percent owned by the company, they will then be shared by the other participants in that property. The effect of charging this expense to the field will be to marginally reduce field economics, with a corresponding impact on company economics. While the impact on the economics of a particular field will likely be minor, if enough costs are allocated to enough fields, the impact on company economics can be significant.

Interest Expense: Financial charges incurred in funding investments are often not included in cash-flow forecasts. From the perspective of discounted cash flows, these charges, which include interest on debt or shareholder returns, have already been considered in the determination of the discount rate. If they were to be incorporated into discounted cash flow calculations, they would effectively be counted twice. From the perspective of annual cash flow, however, the amount of interest to be paid and, for that matter, principal, should be taken into account. This is particularly important at the corporate level because of the implications with respect to corporate liquidity.

One area where interest must be considered is in the determination of income tax. Interest is tax deductible and, it is deducted after resource allowance and before earned depletion.

Working Capital: Changes in working capital are not generally considered in cash flow analysis at the field level; however, it must be recognized that a company will have to fund any increase in its working capital position. This is a particularly relevant item in a startup situation when funds for working capital have to be provided.

Crude Oil Royalty: Crude oil royalties are a function of age, gravity, price and production rate. "Age" refers to the classification of oil as old, new, or third tier. "Old oil" is basically oil discovered prior to April, 1974; "new oil" dates from after March, 1974. "Third tier oil" was introduced as of October, 1992 and initially described as oil from "newly discovered pools," with any further definition to be contained in revisions to regulations.

"Gravity" refers to the classification of oil as either light, medium or heavy with the intention that heavy oil will be subject to a lower royalty. Price adjustment is based on a "par price" and a "select price.". "Production rate" refers to monthly production rate.

Crude oil royalty is calculated according to Equation:

$$R = [S + fS(A - B/A)] \times 100/Q$$

Where, R = the royalty rate (%)

S = the basic royalty

f = the royalty factor

A = the par price

B = the select price

Q = the monthly production rate

When the par price is less than or equal to the select price, the equation simplifies to:

$$R = S/Q \times 100$$

There are two kinds of basic royalty: one defined for new and old oil and the other for third tier oil. In turn, the basic royalty for new and old oil is calculated by using one of two equations: one for production rates less than or equal to 190.7 m³/month and one for production rates over that value. The basic royalty for third tier oil has three values. It is equal to zero for production less than or equal to 20 m³/month and is calculated using one equation for production between 20 and 190.7 m³/month and another for production over 190.7 m³/month.

Production Royalty: Production royalty is defined with reference to the recipient. If the recipient is subject to Crown charges, such as Crown royalties, provincial mineral taxes and road allowance levies, i.e., nondeductible Crown charges for income tax purposes, the royalty is termed a production royalty. This definition is important for tax purposes because production royalty income is eligible for resource allowance. Resource Royalty. Resource royalty is royalty received by a recipient; it is not subject to Crown royalty charge's and is ineligible for resource allowance.

Oil Sands Royalty: Royalty for oil sands development, such as the Syn-crude operation, is usually determined according to contract terms negotiated between the developer and the provincial, and sometimes the federal, government.

Freehold Royalty: Where mineral rights are held by a party other than a government, they are classified as freehold mineral rights, and the lands are generally referred to as freehold lands. Royalty obligations associated with production by other than the owner of the rights are negotiated between the lessor and the lessee.

Mineral Tax. In: the absence of ownership rights on oil and gas produced from freehold lands, and the concomitant right to impose a Crown royalty, governments impose a mineral tax, typically calculated on an annual basis. To illustrate, the following is a discussion of the Freehold Mineral. However, the mineral tax structure is presently being reviewed with a view to possible updating.

This tax is a function of both price and rate, and is substantially lower than Crown royalty, to account for the fact that the producer is paying royalty to the owner of the freehold mineral rights. For crude oil, solution gas and condensate, the tax formula is:

$$tax = R \times V \times M$$

Where, R=tax rate: 0.269 for liquids, 0.069 for solution gas
 V= price per m³ for liquids, or 10³ scm for solution gas
 M = annual production

For solution gas, M is the production in thousands of standard cubic metres. For crude oil and condensate:

$$M = (0.0833Q^2) / 105.94$$

for annual production, Q, less than 2288.4 cubic metres, and:

$$M = (Q/4) - 228.4$$

for Q greater than or equal to 2288.4 cubic metres.

For natural gas, if average daily production for a year is less than 16.9 thousand standard cubic metres:

$$tax = R \times V \times M$$

$$A = R - [(R - 1) \times (16.9 - ADP)^2 / (16.9)^2]$$

Where, R = tax rate; currently 0.069

ADP = average daily production per well

If the average daily production for a year is greater than or equal to 16.9 thousand standard cubic metres, the formula is the same as that for solution gas.

7.4 Federal Corporate Income Tax

Development Expense: The cost is an intangible cost which, generally speaking, is expended in the drilling of wells. It includes the drilling, completing or converting of any well. Amounts in the accumulated DE account may be deducted from taxable income at rates of up to 30 percent of the remaining balance.

Exploration Expense: and includes such things as geological, geophysical and geochemical expense, the drilling of exploration wells, and the cost of dry holes. A principal business corporation, must deduct the lesser of the amount in the account and the company's income for the year.

Oil and Gas Property Expense: This can include drilling and production rights and royalty interests. Cumulative OGPE, the amount in the tax account balance, may be deducted at an annual rate of up to 10 percent of the balance in the account.

Nontangible portions of property sales are charged directly to this account. If a negative balance results at year end, this balance is transferred to the DE account. Any resulting negative balances created in the DE account must go into income.

Earned Depletion: While this item has been effectively eliminated for oil and gas producers, some companies still have an unclaimed earned depletion base that may be utilized as a deduction against Income. A taxpayer is permitted to deduct the lower of the earned depletion, which would have existed under prior legislation, or the remaining base.

Capital Cost Allowance (CCA): This is the tax equivalent of accounting depreciation and in theory allows a business to recover its original tangible asset investment without having to pay tax on it. CCA accumulates in pools of prescribed classes which are deducted, at the option of the taxpayer, on the basis of a fixed percentage of the declining balance.

Tangible costs, which are grouped into CCA, should be differentiated from intangible costs, which are grouped into DE and CEE. As a first approximation, tangible assets are located above ground, although they would also include production tubing and sucker rods.

Production-related assets, which reduce resource allowance, must be differentiated from nonproduction assets, which do not. Again, as a first approximation, equipment which is upstream of an inlet separator is production-related. Production-related CCA is a deductible expense when calculating resource allowance, thereby reducing its effectiveness as a tax shelter for resource income by 25 percent. Accordingly, a taxpayer would be motivated to maximize not only the amount of CCA which is deducted against nonresource income, but also amounts of OGPE, DE and CEE.

Disposal of a tangible asset yields a credit (not to exceed the original cost of the asset) for the pool into which the assets were originally grouped. If a negative balance in the pool results, this balance must be included in income. If the assets in question are production-related, this income will qualify as resource profits.

Successor Rules: Alterations in a corporation's status, brought about by such things as mergers, acquisitions and changes in control, receive particular treatment within the Income Tax Act. A proper understanding of the associated rules and regulations is best left to professional advisors.

7.5 Financial Statements

Companies produce annual financial statements as an accounting of their performance during the year and their status at the end of the year. The information contained in these statements can yield historical annual cash flow numbers.

7.6 Finance And Economic Considerations

Cash flow analysis and investment decision-making have a basis in theory, and to appreciate them some understanding of this theory is important. The following is a simplified discussion of the theory.

Net Present Value (NPV) and Internal Rate of Return (IRR): These are the two most widely used terms in investment decision-making. "Net present value" is the value obtained when all cash flow streams, including the investment, are discounted to the present and totalled. "Internal rate of return" is the discount rate which will give an NPV of zero, meaning the discounted cash flow stream is equal to the cost of the investment.

For investments involving initial expenditure and subsequent inflows of cash, a plot of NPV against discount rate yields a downward sloping curve which shows steadily decreasing NPV with increasing discount rate. This curve intersects the discount rate axis (NPV equal to zero) at the IRR. The apparent drawback of using the IRR is that it, by definition, assumes that the unrecovered investment can be re-invested at this rate. On the other hand, the NPV is expected to be positive, which normally implies that the IRR exceeds the cost of capital. When NPV is used, the investment is to provide a benefit beyond the cost of funding. When IRR is used, the yield is to exceed the cost of funding. In that respect, the two methods are complementary.

Project Abandonment: Use of NPV as a decisionmaking tool should not be limited solely to the initial investment decision. Rather, a project should be checked throughout its life to ensure that it has a positive NPV. If at any point it does not, a sponsor should seriously consider abandoning the project since, from that point on, the investment will be incapable of generating its funding costs. In this regard, the concept of "sunk costs" is introduced; monies that have been spent should no longer be incorporated into the investment decision. Weighted Average Cost of Capital (WACC). The "weighted average cost of capital" is the average aftertax cost to the company of all the components of its capital structure. These are not just loan interest costs but the cost of all forms of debt, including the cost of preferred shares and common shares. Luszti includes internally generated funds, such as retained earnings and depreciation, when discussing a firm's WACC.

All components should be included at their current cost since they will be used when making new investment decisions. The proportions of each can be based on the existing capital structure or a targeted new capital structure with total capitalization based on current market value.

Discount Rate: By definition, an after-tax cash flow stream that is discounted at a firm's WACC and yields a positive NPV will pay for the project's funding costs and generate a residual gain for shareholders. In most situations, therefore, the appropriate discount rate to use is the WACC.

The use of one discount rate for a firm's decisionmaking presumes that all of the firm's projected investments carry the same degree of risk. This may not be the case. Where a

project is perceived to carry a higher risk, an investor would reasonably expect a higher yield. This would result in a higher WACC and a concomitant higher discount rate for the project.

While theory suggests the derivation of a unique discount rate based on a project's WACC, other options are often employed. One common practice is to calculate the discount rate by adding a risk premium to the firm's normal WACC. This risk premium is usually based on intuition and is therefore, by its very nature, somewhat arbitrary. Nevertheless, it is often a practical way around the difficulties inherent in calculating a project WACC.

Apart from the problems associated with determining a risk premium, there is normally some uncertainty attached to deriving any WACC, particularly the equity portion. This is one reason why, in actuality, the discount rate used is often the one that is in popular useage at the time, especially if two parties are negotiating a value.

7.7 Uncertainty And Risk In Reserve Evaluation:

There is always uncertainty in an estimate of the volume or value of oil and gas reserves because few of the factors involved are known with certainty. The traditional deterministic approach does not make any allowance for uncertainty, and stochastic, or statistical, methods are required to assess it. Stochastic methods may be more time-consuming, but they make better use of available data and can yield important information that cannot be obtained from a deterministic evaluation. The degree of uncertainty can be of critical importance to investment and planning decisions, and an inadequate appreciation of it can lead to costly failures. For every evaluation, a decision has to be made as to whether the improved understanding resulting from a stochastic evaluation warrants the additional time that is required. The high cost of failure for most petroleum ventures suggests that stochastic methods should be used more than they are at present.

ESTIMATION OF UNCERTAINTY

Most of the parameters used to estimate reserve values are derived using a combination of subjective and objective methods. All evaluations require ownership and fiscal information,^o but the technical parameters depend on the evaluation method being used. Volumetric evaluations require reservoir parameters (pay thickness, porosity, and water saturation), drainage area, and recovery and formation volume factors. Produced volumes and pressures are needed for material balance and decline curve methods. More complex evaluations will require additional factors to be estimated, for example:

- High, medium and low case maps or alternative interpretations, to estimate reservoir areas
- A histogram of core porosities to represent reservoir porosities
- A price forecast, with a spread of values at any particular time
- Production decline curve parameters estimated by analogy with nearby wells
- Market volumes that depend on predictions of weather and levels of economic activity

- The availability of pipeline capacity
- The probability of war or embargo
- Tax levels

The sources of data used to estimate uncertainty are the same as those for deterministic estimates although stochastic methods generally make better use of the data. The sources vary from proprietary to public.

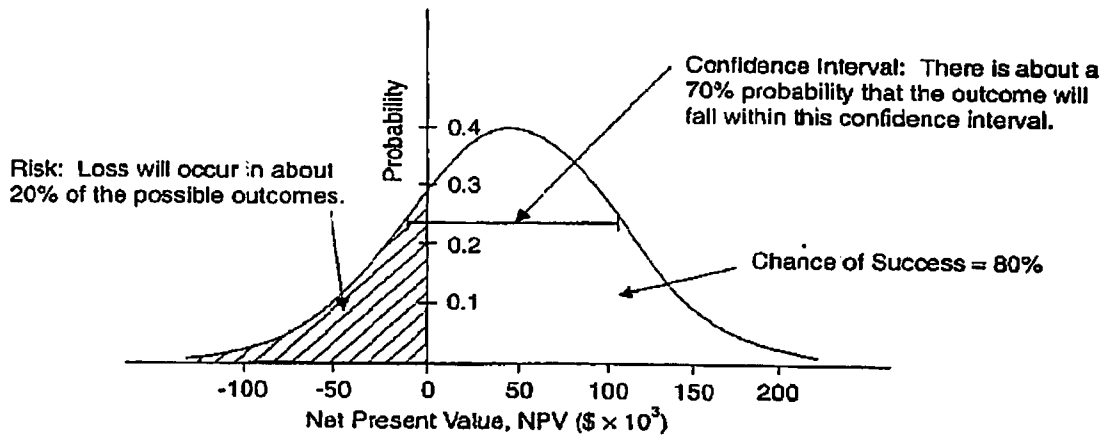

Figure 7(a) probability density function (PDF) of net present value.

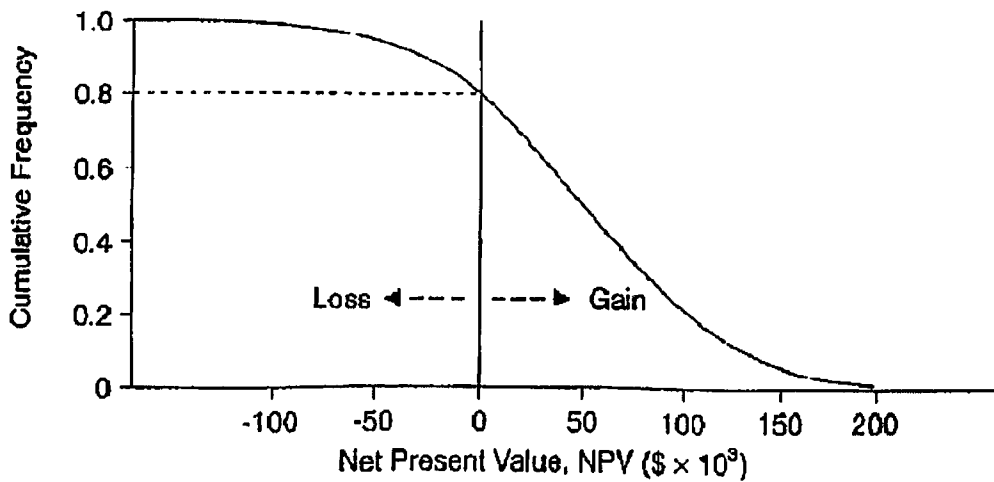

Figure 7(b) cumulative distribution function (CDF) or expectation curve of net present values.

NOTE: 1. Uncertainty is represented by the fact that an outcome could fall anywhere on the NPV axis with differing probabilities.

2. Chance of success is 80%.

3. Risk of loss is 20%.

4. The mean outcome or expectation is $\$50 \times 10^3$.

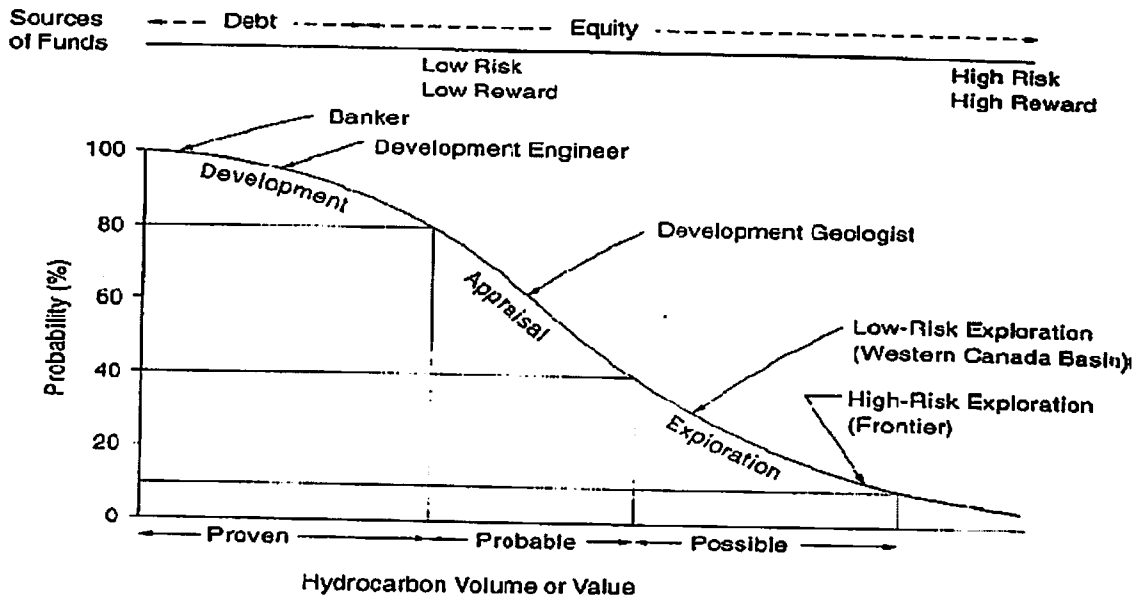

Figure 7(c): expectation curve: (reconciliation of different views of hydrocarbon volumes and values.

For better understanding of the economics following examples have been illustrated:

7.8 EXAMPLE 1: consider an oil field located in northern North Sea (U.K block).

Cash flow has been discounted at rate of 10% from January, 1999

Location: Northern North Sea

Water Depth: 126 meters.

Production Horizon: middle & lower Jurassic and Triassic.

Operator: Total

Recoverable reserves:

320 mmbbls oil

1,967 bcf sales gas

Remaining reserves:

84 mmbbls oil

1,055 bcf sales gas

Discovered: August 1975

Development approval: October 1982

Production start: November 1987

OIL Quality:

- Brent 38-42° API

- Statfjord 48° API

Sulphur = 0.3-0.5 %

GOR = 990-2000 scf/bbl

Year	Production liquids (000b/d)	Gas (mmcf/d)	Gross revenue (£M)	Op costs (£M)	Capital costs (£M)	Royalty (£M)	PRT (£M)	Cop tax (£M)	Total field cash flow (£M)
1982	0	0	0	0	15.4	0	0	0	-15.4
1983	0	0	0	0	135.8	0	0	0	-135.8
1984	0	0	0	0	211.8	0	0	0	-211.8
1985	0	0	0	0	353.9	0	0	0	-353.9
1986	0	0	0	0	342.1	0	0	0	-342.1
1987	2.5	0	10.3	11	301	0	0	0	-301.7
1988	75	226	342	69.8	65	0	0	0	207.2
1989	90	247.5	499.3	74.3	25	0	0	0	400
1990	94	255	597.6	75.5	45	0	0	0	477.1
1991	92	279	558.6	76.4	30	0	0	0	452.2
1992	82.5	257.5	503	73.1	10	0	0	114.6	305.2
1993	67	275.5	470.6	70.8	0	0	0.8	124.3	274.6
1994	44.5	231.5	335.2	63.4	20	0	0	121.4	130.3
1995	30	172.5	248.9	50.5	20	0	0	75.2	103.2
1996	23	171.5	242.4	35.8	20	0	39	53	94.6
1997	21.5	193.5	246.1	38.5	20	0	38.3	42.8	106.5
1998	22.5	188	228.3	33.5	25	0	52.2	40.3	77.2
1999	25	115.1	175.8	28.4	69.7	0	8.4	42.2	27
2000	26	165.1	210.4	31.6	89.2	0	0	36.2	53.4
2001	26	155.1	188.2	27.6	88.8	0	0	40.7	31.1
2002	20	180	187.7	29	49.1	0	13.2	31.8	64.7
2003	25	200	224.4	36.4	29.3	0	71.9	23.9	62.8
2004	22	250	252.9	39.6	0	0	99.6	18.4	95.3

2005	18	210	216.5	35.7	0	0	94.5	21.4	64.9
2006	13	210	202.5	35.8	0	0	85.1	19.1	62.4
2007	10	210	195.8	36.2	0	0	80.7	19	59.9
2008	9	210	197.1	36.9	0	0	80.1	19.4	60.7
2009	8	200	190.5	34.4	0	0	78.5	20.7	56.9
2010	7	180	175.3	33.7	0	0	72.7	20.9	48
2011	6	155.1	155	29.9	0	0	64.6	19.3	41.2
2012	5	120	124.9	28.1	0	0	52	17.3	27.4
2013	4	100	106.2	26.5	0	0	42	13.5	24.3
2014	3	85.1	91	22.1	0	0	35.9	11.2	21.8
2015	2	75.1	79.2	18.4	0	0	31.4	9.7	19.6
2016	2	70	76.7	18.6	0	0	29.4	8.7	20
2017	0	0	0	0	137.1	0	-61.1	8.4	-84.3
2018	0	0	0	0	0	0	0	-20.8	20.8
Totals									
=	875.5	5388.1	7332.4	1221.5	2103.2	0	1009.2	952.6	2045.3

SUMMARY OF RESULTS:

INTERNAL RATE OF RETURN USING EXCEL FUNCTION = 12.72%

NET PRESENT VALUE (NPV) POST-TAX = 2045.3£M

NET PRESENT VALUE (NPV) PRE-TAX = 4007.1£M

RECOVERABLE RESERVES:

Oil = $875.5 \times 1000 \times 365 = 320$ mmbls

Gas = 1967 bcf sales gas

REMAINING RESERVES AS ON 1/1/1999

Oil = 84 mmbls

Gas = 1055 bcf sales gas

IRR post-tax = 12.72 %

IRR pre-tax = 16.16 %

Payback period = 9.6 yrs

RESERVE LIFE AT CURRENT PRODUCTION = 16.3 yrs

7.9 EXAMPLE 2: Consider an oil field situated on the shores of lipan river (U.S.A, Texas).

Basic data:

Production decline rate = 0.83591841/year (exponential decline)

Current oil price = 25\$ /barrel

Oil price escalation = 1.5% /year

Current contr. Overhead = 10, 00,000 /year

OH escalation = 2% /year

Current DOC:

Fixed = 1. 20, 00,000 \$ /year

Variable = 4.50 \$ /barrel

DOC escalation = 2.0 % /year

Contract terms:

NOC share of profit oil = 80 %

Contr. Share profit oil = 20 %

Cost oil limit = 40 % of gross revenue.

Royalty = 20% of gross revenue.

Income tax = 0% (paid by NOC)

· Hurdle rate = 10 %

(1)	(2)	(3)	(4)	(5)	(6)	(7)	(8)
	EXPL.& DEV INVESTMENT	BONUSES	YR.END PROD.RATE	ANNUAL PROD.	OIL PRICE	GROSS REVENUE	ROYALTY PAYMENTS
<u>Y</u> <u>R.</u>	<u>(\$)</u>	<u>(\$)</u>	<u>(BBL/DAY)</u>	<u>(BBL)</u>	<u>(\$/BBL)</u>	<u>(\$)</u>	<u>(\$)</u>
1	\$1.00,00,000	\$1.50,00,000	0	0	\$25.00	\$0	\$0
2	\$2.00,00,000	\$0	0	0	\$25.38	\$0	\$0
3	\$5.00,00,000	\$50,00,000	0	0	\$25.76	\$0	\$0
4	\$15.00,00,000	\$0	15,000	27,37,500	\$26.14	\$7,15,63,614	\$1,43,12,723
5	\$8.00,00,000	\$50,00,000	30,000	82,12,500	\$26.53	\$21,79,11,204	\$4,35,82,241
6		\$0	45,000	1,36,87,500	\$26.93	\$36,86,33,120	\$7,37,26,624
7		\$0	45,000	1,64,25,000	\$27.34	\$44,89,95,140	\$8,97,99,028
8		\$0	45,000	1,64,25,000	\$27.75	\$45,57,30,067	\$9,11,46,013
9		\$0	45,000	1,64,25,000	\$28.16	\$46,25,66,018	\$9,25,13,204
10		\$0	45,000	1,64,25,000	\$28.58	\$46,95,04,509	\$9,39,00,902
11		\$0	41,391	1,57,66,412	\$29.01	\$45,74,39,113	\$9,14,87,823
12		\$0	38,072	1,45,02,050	\$29.45	\$42,70,66,851	\$8,54,13,370
13		\$0	35,019	1,33,39,081	\$29.89	\$39,87,11,195	\$7,97,42,239
14		\$0	32,211	1,22,69,375	\$30.34	\$37,22,38,249	\$7,44,47,650
15		\$0	29,628	1,12,85,452	\$30.79	\$34,75,23,009	\$6,95,04,602
16		\$0	27,252	1,03,80,433	\$31.26	\$32,44,48,769	\$6,48,89,754

17		\$0	25,066	95,47,991	\$31.72	\$30,29,0 6,573	\$6,05,81,315
18		\$0	23,056	87,82,305	\$32.20	\$28,27,9 4,699	\$5,65,58,940
19		\$0	21,207	80,78,023	\$32.68	\$26,40,1 8,179	\$5,28,03,636
20		\$0	19,506	74,30,219	\$33.17	\$24,64,8 8,350	\$4,92,97,670
21		\$0	17,942	68,34,364	\$33.67	\$23,01,2 2,437	\$4,60,24,487
22		\$0	16,503	62,86,293	\$34.18	\$21,48,4 3,160	\$4,29,68,632
23		\$0	15,180	57,82,174	\$34.69	\$20,05,7 8,370	\$4,01,15,674
24		\$0	13,963	53,18,482	\$35.21	\$18,72,6 0,710	\$3,74,52,142
25		\$0	12,843	48,91,975	\$35.74	\$17,48,2 7,293	\$3,49,65,459
26		\$0	11,813	44,99,671	\$36.27	\$16,32,1 9,408	\$3,26,43,882
27		\$0	10,866	41,38,827	\$36.82	\$15,23,8 2,245	\$3,04,76,449
28		\$0	9,994	38,06,920	\$37.37	\$14,22,6 4,628	\$2,84,52,926
29		\$0	9,193	35,01,630	\$37.93	\$13,28,1 8,784	\$2,65,63,757
30		\$0	8,456	32,20,823	\$38.50	\$12,40,0 0,109	\$2,48,00,022
To tal	\$31,00,00,00 0	\$2,50,00,000		25,00,00,000		7,64,08,5 5,803	1,52,81,71,161

(9)	(10)	(11)	(12)	(13)
		← - - -	COST ACCOUNT	OIL - - - →
OVERHEAD	TOTAL DOC	CURRENT	TO CONTR.	UNPAID BALANCE
(\$)	(\$)	(\$)	(\$)	(\$)
\$10,00,000	0	\$1,10,00,000	\$0	\$1,10,00,000
\$10,20,000	0	\$2,10,20,000	\$0	\$3,20,20,000
\$10,40,400	0	\$5,10,40,400	\$0	\$8,30,60,400
\$10,61,208	\$2,58,07,252	\$17,68,68,460	\$2,86,25,446	\$23,13,03,415
\$10,82,432	\$5,29,91,819	\$13,40,74,252	\$8,71,64,482	\$27,82,13,185
\$11,04,081	\$8,12,53,447	\$8,23,57,527	\$14,74,53,248	\$21,31,17,464
\$11,26,162	\$9,67,51,429	\$9,78,77,591	\$17,95,98,056	\$13,13,96,999
\$11,48,686	\$9,86,86,457	\$9,98,35,143	\$18,22,92,027	\$4,89,40,115
\$11,71,659	\$10,06,60,187	\$10,18,31,846	\$15,07,71,961	\$0
\$11,95,093	\$10,26,73,390	\$10,38,68,483	\$10,38,68,483	\$0
\$12,18,994	\$10,11,14,189	\$10,23,33,183	\$10,23,33,183	\$0
\$12,43,374	\$9,60,62,134	\$9,73,05,508	\$9,73,05,508	\$0
\$12,68,242	\$9,13,46,212	\$9,26,14,454	\$9,26,14,454	\$0
\$12,93,607	\$8,69,46,131	\$8,82,39,738	\$8,82,39,738	\$0
\$13,19,479	\$8,28,42,860	\$8,41,62,339	\$8,41,62,339	\$0
\$13,45,868	\$7,90,18,555	\$8,03,64,424	\$8,03,64,424	\$0
\$13,72,786	\$7,54,56,485	\$7,68,29,271	\$7,68,29,271	\$0
\$14,00,241	\$7,21,40,962	\$7,35,41,204	\$7,35,41,204	\$0
\$14,28,246	\$6,90,57,279	\$7,04,85,526	\$7,04,85,526	\$0
\$14,56,811	\$6,61,91,648	\$6,76,48,459	\$6,76,48,459	\$0
\$14,85,947	\$6,35,31,144	\$6,50,17,091	\$6,50,17,091	\$0
\$15,15,666	\$6,10,63,650	\$6,25,79,316	\$6,25,79,316	\$0

\$15,45,980	\$5,87,77,812	\$6,03,23,792	\$6,03,23,792	\$0
\$15,76,899	\$5,66,62,987	\$5,82,39,886	\$5,82,39,886	\$0
\$16,08,437	\$5,47,09,202	\$5,63,17,639	\$5,63,17,639	\$0
\$16,40,606	\$5,29,07,112	\$5,45,47,718	\$5,45,47,718	\$0
\$16,73,418	\$5,12,47,963	\$5,29,21,381	\$5,29,21,381	\$0
\$17,06,886	\$4,97,23,551	\$5,14,30,438	\$5,14,30,438	\$0
\$17,41,024	\$4,83,26,196	\$5,00,67,220	\$5,00,67,220	\$0
\$17,75,845	\$4,70,48,701	\$4,88,24,546	\$4,88,24,546	\$0
Total =				
\$4,05,68,079	\$1,92,29,98,755	\$2,27,35,66,834	\$2,27,35,66,834	

(14)	(15)	(16)	(17)	(18)
← - - - -	PROFIT OIL	- - - - - →		
TOTAL	NOC	CONTR.	CONTR'S.	CUMULATIVE CONTR'S
	80%	20%	NCF	NCF
(\$)	(\$)	(\$)	(\$)	(\$)
\$0	\$0	\$0	(\$2,60,00,000)	(\$2,60,00,000)
\$0	\$0	\$0	(\$2,10,20,000)	(\$4,70,20,000)
\$0	\$0	\$0	(\$5,60,40,400)	(\$10,30,60,400)
\$2,86,25,446	\$2,29,00,356	\$57,25,089	(\$14,25,17,925)	(\$24,55,78,325)
\$8,71,64,482	\$6,97,31,585	\$1,74,32,896	(\$3,44,76,874)	(\$28,00,55,199)
\$14,74,53,248	\$11,79,62,598	\$2,94,90,650	\$9,45,86,370	(\$18,54,68,829)
\$17,95,98,056	\$14,36,78,445	\$3,59,19,611	\$11,76,40,076	(\$6,78,28,753)
\$18,22,92,027	\$14,58,33,622	\$3,64,58,405	\$11,89,15,289	\$5,10,86,536
\$21,92,80,854	\$17,54,24,683	\$4,38,56,171	\$9,27,96,286	\$14,38,82,822
\$27,17,35,124	\$21,73,88,099	\$5,43,47,025	\$5,43,47,025	\$19,82,29,847
\$26,36,18,107	\$21,08,94,486	\$5,27,23,621	\$5,27,23,621	\$25,09,53,469
\$24,43,47,973	\$19,54,78,378	\$4,88,69,595	\$4,88,69,595	\$29,98,23,063
\$22,63,54,502	\$18,10,83,601	\$4,52,70,900	\$4,52,70,900	\$34,50,93,963
\$20,95,50,861	\$16,76,40,689	\$4,19,10,172	\$4,19,10,172	\$38,70,04,136
\$19,38,56,068	\$15,50,84,854	\$3,87,71,214	\$3,87,71,214	\$42,57,75,349
\$17,91,94,591	\$14,33,55,673	\$3,58,38,918	\$3,58,38,918	\$46,16,14,268
\$16,54,95,987	\$13,23,96,790	\$3,30,99,197	\$3,30,99,197	\$49,47,13,465
\$15,26,94,555	\$12,21,55,644	\$3,05,38,911	\$3,05,38,911	\$52,52,52,376
\$14,07,29,018	\$11,25,83,214	\$2,81,45,804	\$2,81,45,804	\$55,33,98,180
\$12,95,42,221	\$10,36,33,777	\$2,59,08,444	\$2,59,08,444	\$57,93,06,624
\$11,90,80,859	\$9,52,64,687	\$2,38,16,172	\$2,38,16,172	\$60,31,22,795
\$10,92,95,212	\$8,74,36,169	\$2,18,59,042	\$2,18,59,042	\$62,49,81,838

\$10,01,38,905	\$8,01,11,124	\$2,00,27,781	\$2,00,27,781	\$64,50,09,619
\$9,15,68,682	\$7,32,54,945	\$1,83,13,736	\$1,83,13,736	\$66,33,23,355
\$8,35,44,195	\$6,68,35,356	\$1,67,08,839	\$1,67,08,839	\$68,00,32,194
\$7,60,27,808	\$6,08,22,247	\$1,52,05,562	\$1,52,05,562	\$69,52,37,756
\$6,89,84,415	\$5,51,87,532	\$1,37,96,883	\$1,37,96,883	\$70,90,34,639
\$6,23,81,265	\$4,99,05,012	\$1,24,76,253	\$1,24,76,253	\$72,15,10,892
\$5,61,87,808	\$4,49,50,246	\$1,12,37,562	\$1,12,37,562	\$73,27,48,453
\$5,03,75,541	\$4,03,00,433	\$1,00,75,108	\$1,00,75,108	\$74,28,23,562
Total \$3,83,91,17,808	= \$3,07,12,94,246	\$76,78,23,562	\$74,28,23,562	

We have calculated contr's NCF and cumulative contr's NCF, now we shall calculate these values at a hurdle rate of 10 % and then find out NPV.

CONTR.NCF	CONTR. CUM. NCF	PV TOTAL INVESTMENT	PV CONTR.NCF	PV CONTR.CUM. NCF
<u>(\$)</u>	<u>(\$)</u>	<u>10%</u>	<u>10%</u>	<u>10%</u>
(\$2.60,00,000)	(\$2,60.00,000)	\$2,38.36,565	(\$2.47,90,027)	(\$2,47,90,027)
(\$2.10,20,000)	(\$4,70.20,000)	\$1,73.35,683	(\$1,82,19,803)	(\$4,30,09,831)
(\$5.60,40,400)	(\$10,30,60,400)	\$4,33.39,209	(\$4,41,59,029)	(\$8,71,68,859)
(\$14,25,17,925)	(\$24,55,78,325)	\$10,74,52,583	(\$10,20,92,795)	(\$18,92,61,654)
(\$3.44,76,874)	(\$28,00,55,199)	\$5,53.54,361	(\$2,24,52,298)	(\$21,17,13,952)
\$9,45,86,370	(\$18,54,68,829)		\$5,59,97,520	(\$15,57,16,433)
\$11,76,40,076	(\$6,78,28,753)		\$6,33,14,451	(\$9,24,01,982)
\$11,89,15,289	\$5,10,86,536		\$5,81,82,524	(\$3,42,19,458)
\$9,27,96,286	\$14,38,82,822		\$4,12,75,541	\$70,56,083
\$5,43,47,025	\$19,82,29,847		\$2,19,75,829	\$2,90,31,912
\$5,27,23,621	\$25,09,53,469		\$1,93,81,261	\$4,84,13,173
\$4,88,69,595	\$29,98,23,063		\$1,63,31,379	\$6,47,44,552
\$4,52,70,900	\$34,50,93,963		\$1,37,53,416	\$7,84,97,968
\$4,19,10,172	\$38,70,04,136		\$1,15,74,925	\$9,00,72,893
\$3,87,71,214	\$42,57,75,349		\$97,34,541	\$9,98,07,433
\$3,58,38,918	\$46,16,14,268		\$81,80,282	\$10,79,87,715
\$3,30,99,197	\$49,47,13,465		\$68,68,125	\$11,48,55,840
\$3,05,38,911	\$52,52,52,376		\$57,60,784	\$12,06,16,623
\$2,81,45,804	\$55,33,98,180		\$48,26,685	\$12,54,43,309
\$2,59,08,444	\$57,93,06,624		\$40,39,094	\$12,94,82,403
\$2,38,16,172	\$60,31,22,795		\$33,75,374	\$13,28,57,777
\$2,18,59,042	\$62,49,81,838		\$28,16,362	\$13,56,74,138
\$2,00,27,781	\$64,50,09,619		\$23,45,835	\$13,80,19,973
\$1,83,13,736	\$66,33,23,355		\$19,50,064	\$13,99,70,037
\$1,67,08,839	\$68,00,32,194		\$16,17,430	\$14,15,87,467

\$1,52,05,562	\$69,52,37,756		\$13,38,101	\$14,29,25,568
\$1,37,96,883	\$70,90,34,639		\$11,03,760	\$14,40,29,329
\$1,24,76,253	\$72,15,10,892		\$9,07,372	\$14,49,36,701
\$1,12,37,562	\$73,27,48,453		\$7,42,986	\$14,56,79,687
\$1,00,75,108	\$74,28,23,562		\$6,05,572	\$14,62,85,258
Total = \$74,28,23,562		\$24,73,18,401	\$14,62,85,258	

. Summary of results:

Initial total recoverable reserves = 25, 00, 00, 000 barrels

Contractor's NCF = \$74, 28, 23.562

$$\text{Profit to investment ratio} = \frac{\text{undiscounted NCF}}{\text{total investment}} = \frac{74,28,23,562}{33,50,00,000} = 2.217 \text{ or } 221.7\%$$

NPV at a hurdle rate of 10% = \$14, 62, 85, 258

$$\text{DROI at a hurdle rate of } 10\% = \frac{14,62,85,258}{24,73,18,401} = 0.591$$

Payout time un-discounted = 7.57 yrs (calculated from cum. NCF)

Payout time present value = 8.83 yrs (calculated from cum. pv NCF @10%)

. IRR using excel function = 19.77%

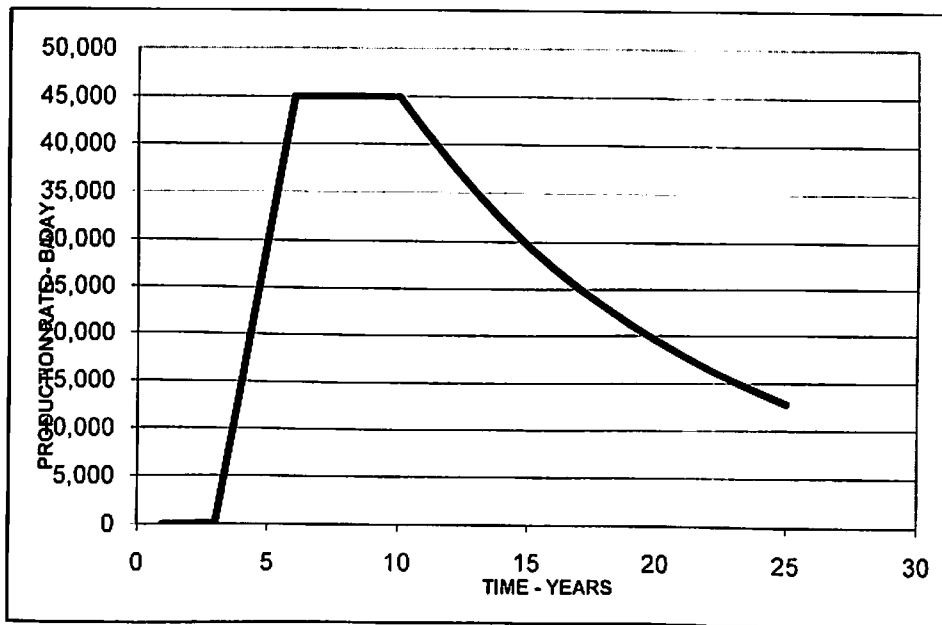

Figure-7(d): plot of production rate Vs time

Chapter 8: CASE STUDY

Objective: To provide Technological Scheme for Development of an oil field.

8.1 Introduction: Oil and natural gas play an immense role in the growth of industry and so the upliftment of the country.

The Development of the reservoir starts as soon as the hydrocarbon bearing area is delineated and only few wells have been drilled. It is required to produce the hydrocarbons from this area so as to achieve maximum recovery with minimum production cost. This scheme is classified as the Technological scheme for the development of the oil/gas field. This scheme is based on the meager data available from the few wells drilled as exploratory wells and is basically to get the financial sanctions. The plan is supposed to give the value of oil/gas reserves present, how to produce, technique of production, economic life of field etc.

The conditions for rational development of reservoir are that

- a) Wells should be spaced so as to have minimum interference between adjoining wells for production of oil/gas.
- b) Reservoir energy to be utilized to the maximum to achieve maximum recovery and
- c) The cost of development of reservoir should be as low as possible

To meet this objective following studies are carried out:

- 1) prepare a geological model
- 2) Estimate oil/gas reserves
- 3) Indicate the number of locations where wells are to be drilled to produce hydrocarbons.
- 4) Predict the oil, gas and water production rates from the field.
- 5) Assess the technique of production of hydrocarbons
- 6) To make performance prediction for about 15-20 yrs.
- 7) Indicate the self flow period and when it is necessary to install artificial mechanism for production of oil.
- 8) EOR technique or pressure maintenance if any,
- 9) Techno-economic analysis etc...

8.2 Well Spacing:

The subject of well spacing is one of vital importance to the petroleum industry. Efficient exploitation of oil and gas reserves demands careful choice of well location and well spacing.

After discovering hydrocarbon and delineation, it is desired to develop this area so as to obtain optimum production.

The well spacing mainly depends on permeability of formation, wider spacing for high permeable reservoirs and narrow for low permeable reservoirs. Efficient exploitation of oil and gas reserves demands careful choice of well location and well spacing. The well spacing must take into account the productivity and injectivity of the production and injection wells respectively. The maximum efficient production rate or the sustained production well deliverability is a function of the reservoir fluids and their characteristics. The deliverability of the heavy oil reservoirs in shallower formations and at lower reservoir pressures tends to be much lower than deeper light oil traps at higher reservoir pressures. The type of well also makes a great deal of difference to the sustained rate a production can deliver. It is therefore; clear that the number of wells and their spacing would also depend upon whether such wells are vertical, deviated or horizontal wells.

The subject of well numbers, their spacing and location and the types of wells etc is quite complex and plays a significant role in the development of hydrocarbon reservoirs. An optimum utilization of the wells is an integral part of any good reservoir performance and is a must for achieving the best possible recovery and commercial gain. The production data needs to be continuously monitored and analyzed to add in-fill wells and recomplete some the existing-wells.

Following criteria should be kept in mind:

- 1) Wells to be drilled at optimum spacing, as the cost of well is very high.
- 2) Wells to be drilled keeping future plan of production in mind such as pressure maintenance or EOR techniques.
- 3) Well completion policy in multi layered reservoirs
- 4) Fluid properties and reservoir characteristics
- 5) Transfer of wells to higher pay zones if any
- 6) Sale price of oil

8.3 Evolution of Well- Spacing Concepts:

Cutler's Rule

In 1924, as part of study to estimate underground oil reserves by oil –well production curves.

Detailed study has shown that physical recoveries of oil from wells on tracts developed to different densities in the same field. He deduces from these data the following tentative rule.

"The ultimate productions for wells of equal size in the same pool where there is interference (shown by a difference in the production decline curves for different spacing) seem approximately to vary directly as the square roots of the areas drained by the wells."

"The recovery from wells of equal size producing under similar conditions in the same pool is proportional to the average distance that the oil moves to get to the well. From this rule, it follows that where interference exists between wells, doubling the distance between wells doubles the ultimate production per well and halves the ultimate recovery per acre"

In most of the analysis it is observed that variations in actual recoveries with well density between different leases in the same field can be attributed to regional migration, that the expenditure of energy for horizontal movement of oil in the reservoir is only a minor and insignificant part of the whole recovery picture.

Relationship between well spacing and recovery:

For many years, operators and technologists have conducted investigations to evaluate the influence of well spacing on oil recovery. Proponents of close spacing failed to recognize intrafield drainage as the basic factor contributing to the higher recoveries obtained by more densely drilled areas.

It was recognized that any attempt to determine the effect of well spacing upon the ultimate recoveries from these fields must first consider other factors such as formation characteristics, the reservoir oil properties, and the degree of control of the available expulsive forces by the operator, all of which are known to exert an influence on the recovery of oil. To isolate and identify a possible effect of well spacing on the ultimate oil recoveries from these fields, it was necessary, then, that the effects of these other influencing and simultaneously occurring factors be systematically evaluated and then eliminated before determining whether a relation exists between oil recovery and well spacing.

The following well patterns are in general considered:

1. **Direct Line Drive:** The locations of wells are kept one below the other. The location of wells in rows can be different from those in the columns depending on the reservoir characteristics. This type of pattern is applicable when the formation is homogeneous and uniform. Ratio of injection wells to production wells in this pattern is one.

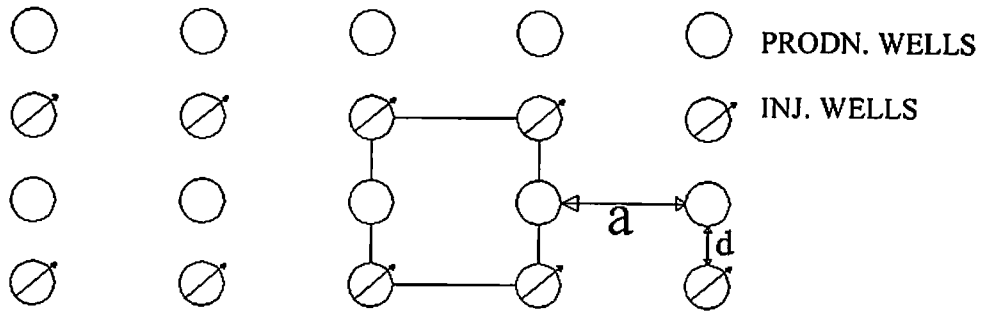

2. **Staggered Line Drive:** The locations of wells are given in a row. However the locations of wells in alternate rows are such that they lie in between the well positions in above and below rows. This pattern is considered when the formation is heterogeneous. The ratio of production wells to injection wells is unity. Here also the alternative rows of wells may be converted to injectors.

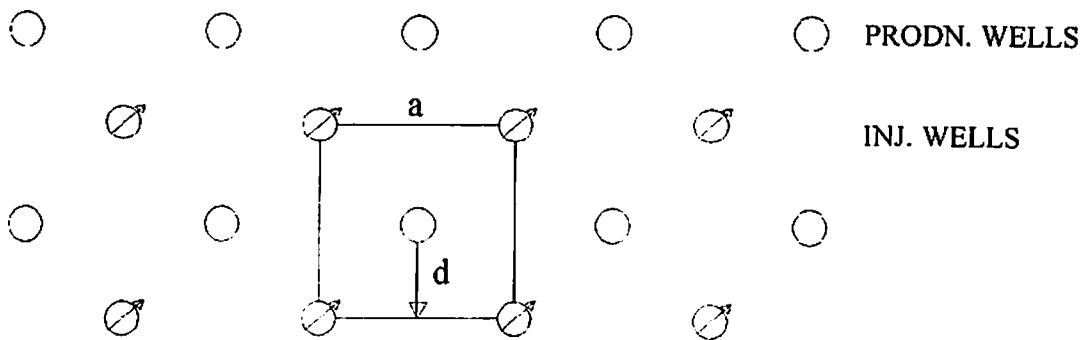

3. **Five Spot Pattern:** Five spot pattern is like a Staggered line Drive. However the distance between locations of wells in row is twice the distance between rows. All other conditions about the reservoir characteristics and fluid properties are the same as in case of staggered line drive.

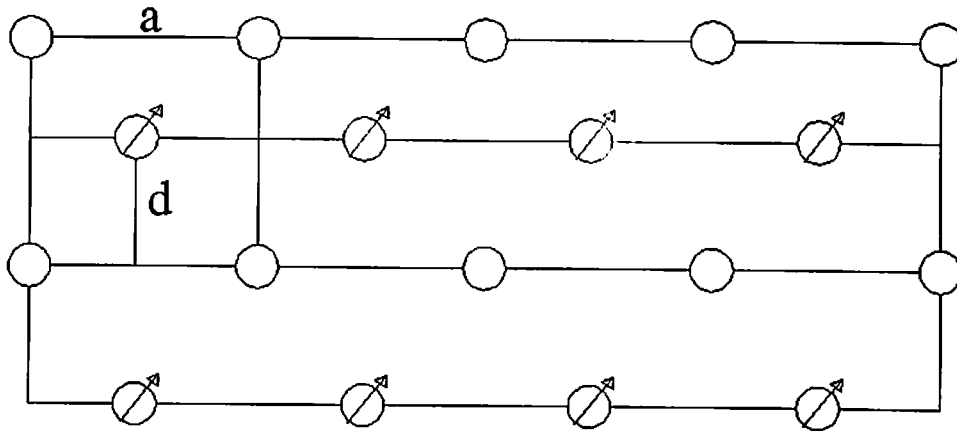

4. **Seven Spot Pattern:** It is in the shape of regular hexagon. Six locations of wells are on each corner of hexagon and seventh location is in the centre. The distance between wells can be different in different formations. Here two types of hexagons are possible. In one case the injection wells is in the centre of hexagon and in other case the central wells are on corners. It is known as normal seven spot when the producing well is at the centre and inverted seven spot in other case.

Normal seven spot pattern is considered for tight formation where injectivity of wells is poor. The sweep efficiency in seven spot patterns is better than in five spot patterns. When the permeability of formation is good, inverted seven spot pattern is chosen. Here one injection well can fill in the voidage created by two production wells. The sweep efficiency is the same as in normal seven spot pattern. The ratio of injection to production wells is 1:2.

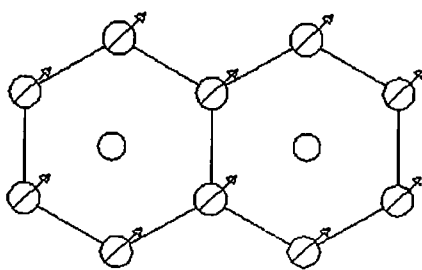

Normal seven spot pattern

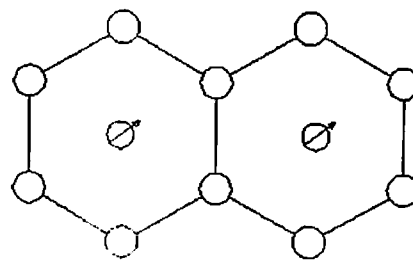

Inverted seven spot pattern

5. **Nine spot Pattern:** the consideration of nine spot pattern wells is the same as in case of seven spot pattern except that the Sweep efficiency is more than in seven spot pattern. Here also nine spot pattern consists of normal nine spot pattern and inverted nine spot pattern. The selection of normal or inverted pattern would depend on formation characteristics. The ratio of injection wells to production wells is 1:3 & 3:1.

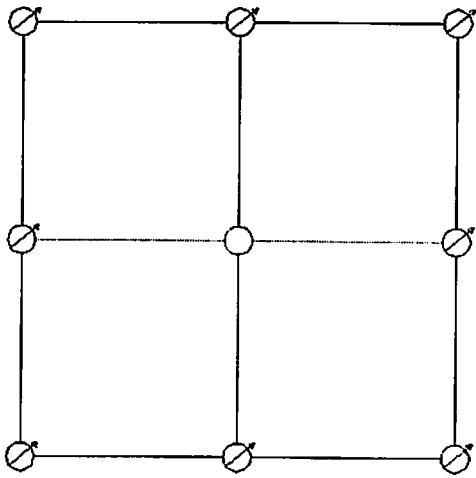

Normal nine spot pattern

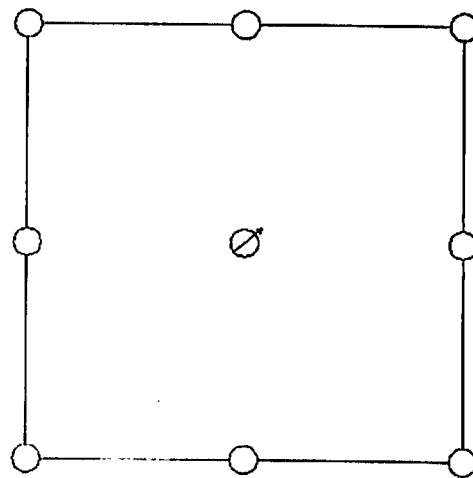

Inverted nine spot pattern

6. **Peripheral Line Drive:** Locations of wells are either on direct line or staggered line drive pattern but injection wells at the time of water injection would be placed on periphery. Water injection can be from one side or both sides. It is always better to convert the producing wells located at the boundary of the reservoir to injectors provided they get flooded before the start of injection. This would save the cost of drilling of wells for injection purposes. In case wells are not available at the periphery or time taken is too long to flood these wells or it is advantageous to inject water immediately, wells may be drilled for injection purposes. The advantages of peripheral line drive is that sweep efficiency is better, water free oil is available for longer period, displacement efficiency is better, water does not enter into the whole of reservoir, less water cut, low cost of development etc. this would result in higher recovery.

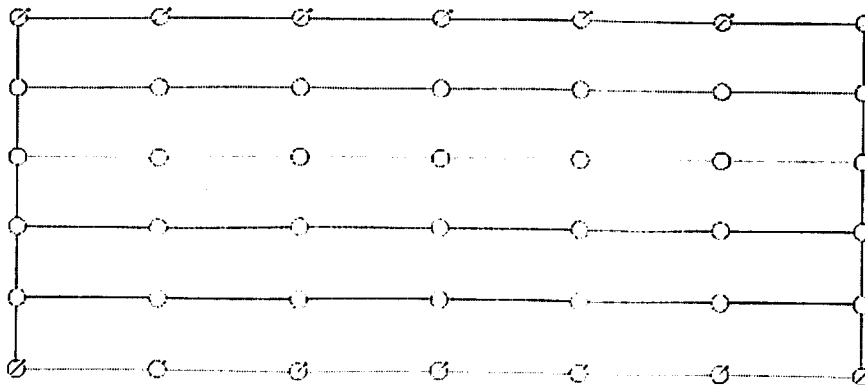

7. **Central line drive:** This system wells pattern is just like line drive. The other conditions regarding reservoir characteristics and fluid properties and advantages are the same as in case of peripheral line drive except the injection row of wells is at the center. This type of pattern is applicable when the reservoir is quite big and there are more than three production rows; the effect of injection is very low and full advantage is not achieved. Therefore it becomes necessary to divide the reservoir in two or more than two parts.

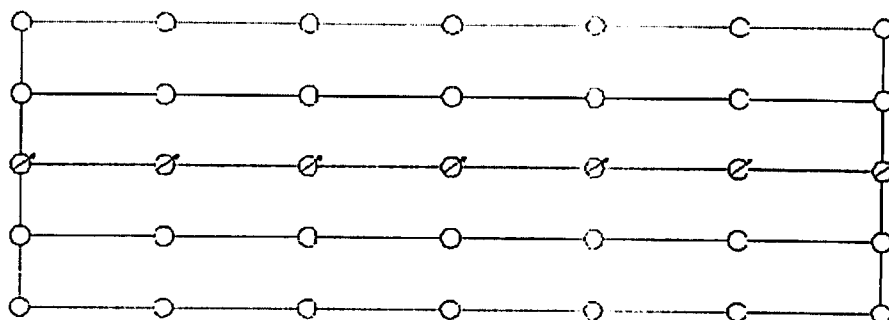

Geology of the Field that has been studied.

Trap: Structural and stratigraphic structure traps

Reservoirs:

- 1) Sandstone/ Siltstone of Eocene/Oligocene in passive margin
- 2) Miocene sandstone
- 3) Fracture Deccan trap volcanic

Source Rock:

Paleocene, Early and Middle Eocene Shale.

Geological background:

- Cambay Basin is an intracratonic graben trending NNW-SSE. In North-West, it is flanked by Aravali ridge, on its east and south by Deccan craton. It is bounded on both the sides by basement margin faults. Cambay basin is divided into four tectonic blocks, namely Ahmedabad -Mehsana , Cambay- Tarapur, Jambusar- Bharuch and Narmada blocks from north to south.

Iso-Pay Thickness Map of Sand-Suraj Pay , Sand I, Santhal:

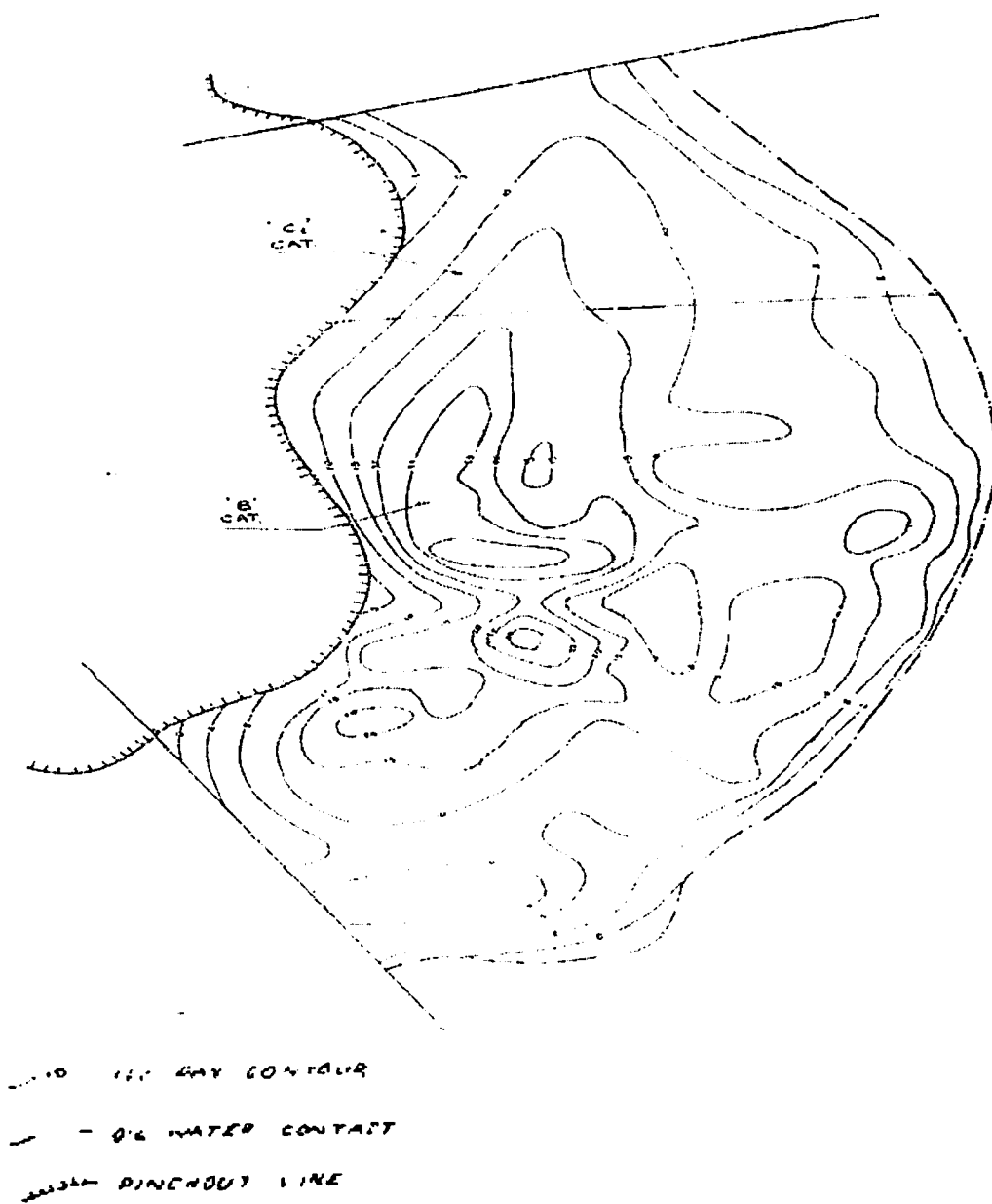
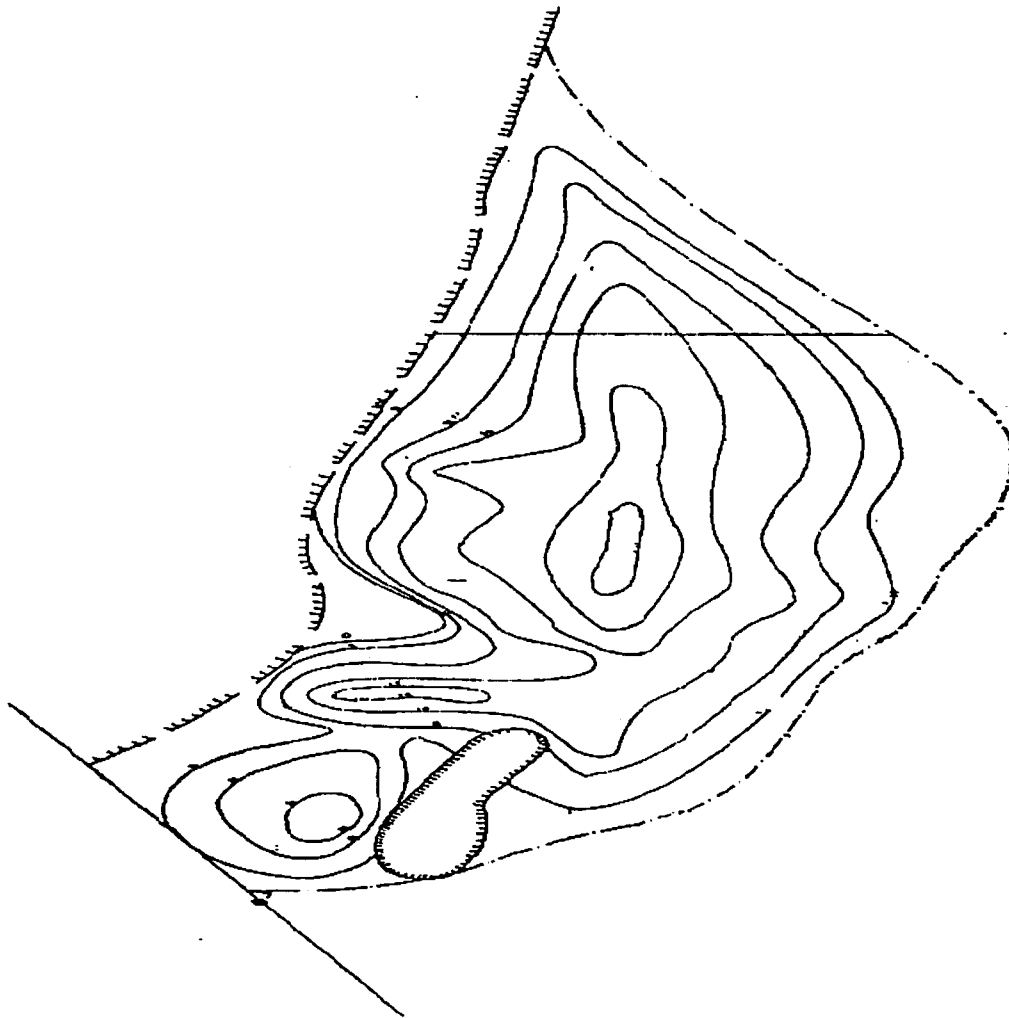

Figure- 8(a) Iso-Pay Thickness Map of Sand-Suraj Pay , Sand I, Santhal

Iso Pay thickness Map of Sand II, Santhal



--- 10' PAY CONTOUR
- - - OIL-WATER CONTACT
—— PINCHOUT LINE

Figure- 8(b) Iso Pay thickness Map of Sand II, Santhal

8.4 Iso Pay Maps: The layerwise information as provided by contour maps are of incomplete use to the geologist, since they by themselves do not provide information on the thickness of each layer. Also the geometry of a sand body, as expressed by an isopach map, gives us the depositional environment of the reservoir. Most importantly, Isopay maps solve the dual purpose of contour maps as well as providing us with layerwise thickness pattern which can give us an idea of reserves in place.

The reservoir that has been considered here is situated in north of cambay basin. And our aim is to develop a technological scheme for the oil field development in santhol.

The reservoir consist of three zones of formation Sand I, Sand II and Sand III+L.S (lower Sands).The depth of SandI zone is (975-1000m). Depth of SandII is (1020-1038m). Depth of Sand III is (1038-1075m).

The cotours are spreaded at the bottom it indicates a flat surface. On moving upwards (oil-water contact) the contours are closely spaced. The Reservoir is a perfect anticline. There is fault on both sides of the Reservoir. On top of the reservoir there is pinch out which implies that it is a Combination Trap.

Geological Cross Section:

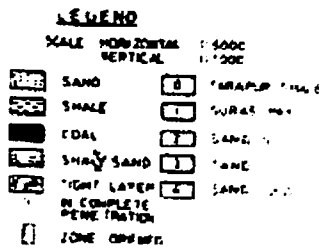
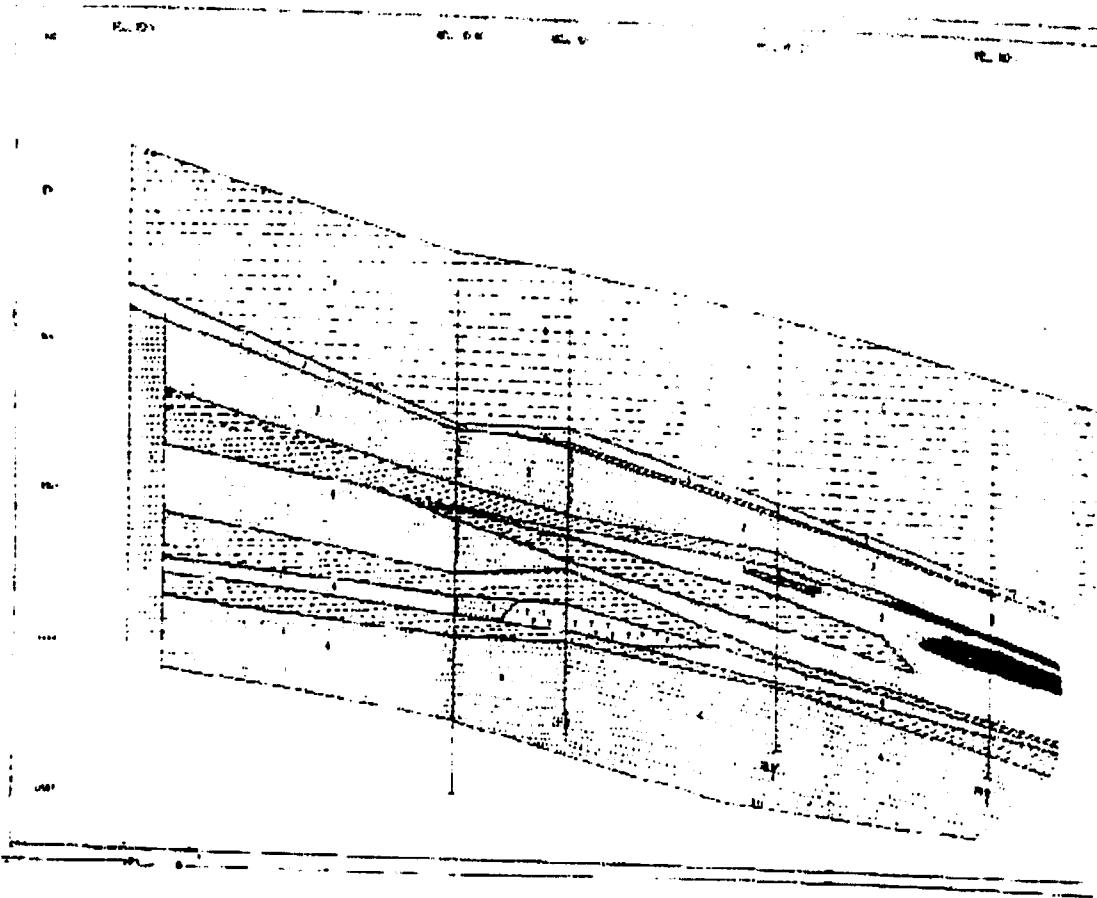

Figure- 8(d-1) Geological Cross Section

Geological Cross Section:

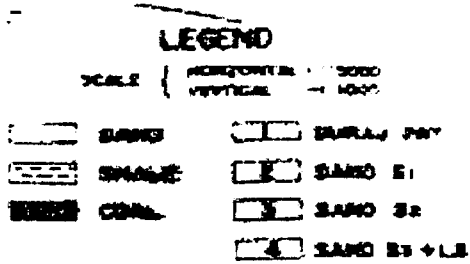
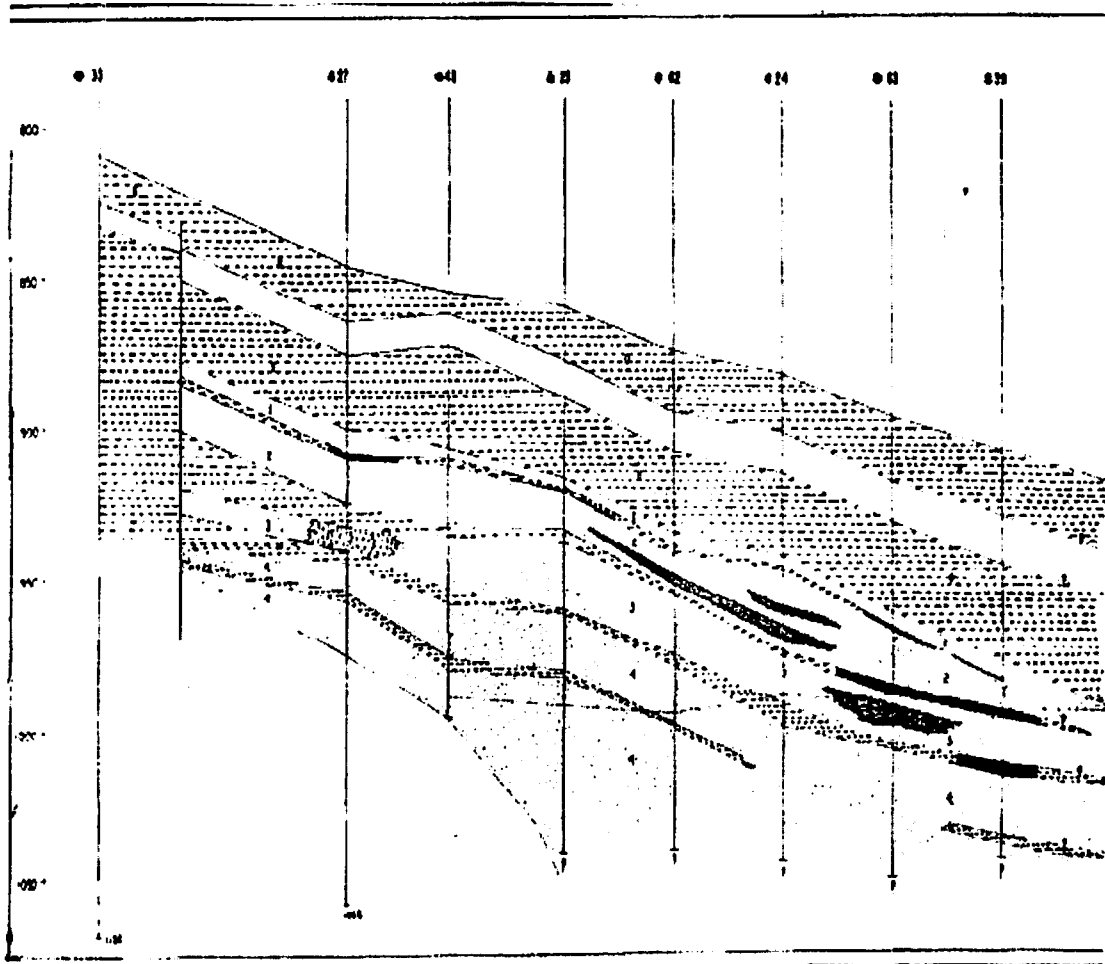

Figure- 8(d-2) Geological Cross Section

Pressure Vs Rs

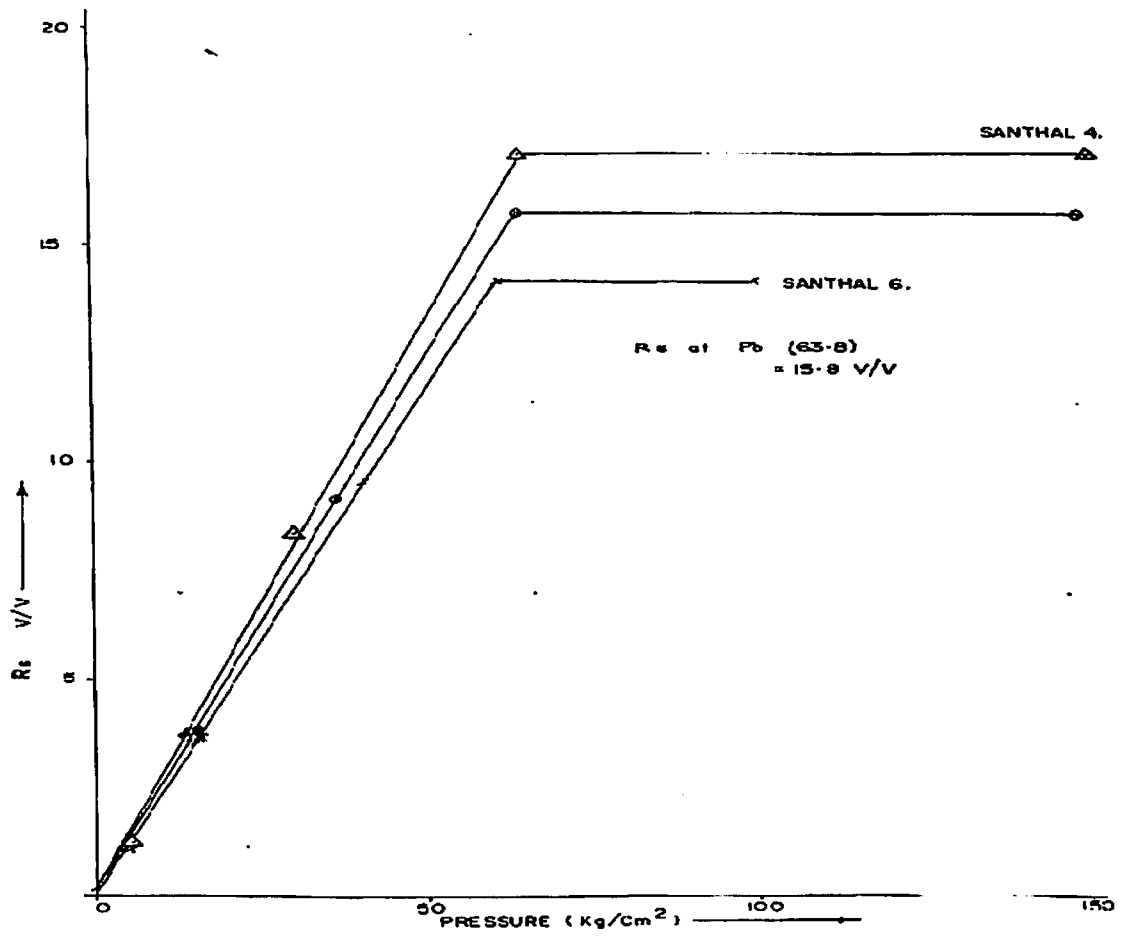

Figure- 8 (e) Pressure Vs Rs

Pressure Vs B_0 (Sand I and Sand II)

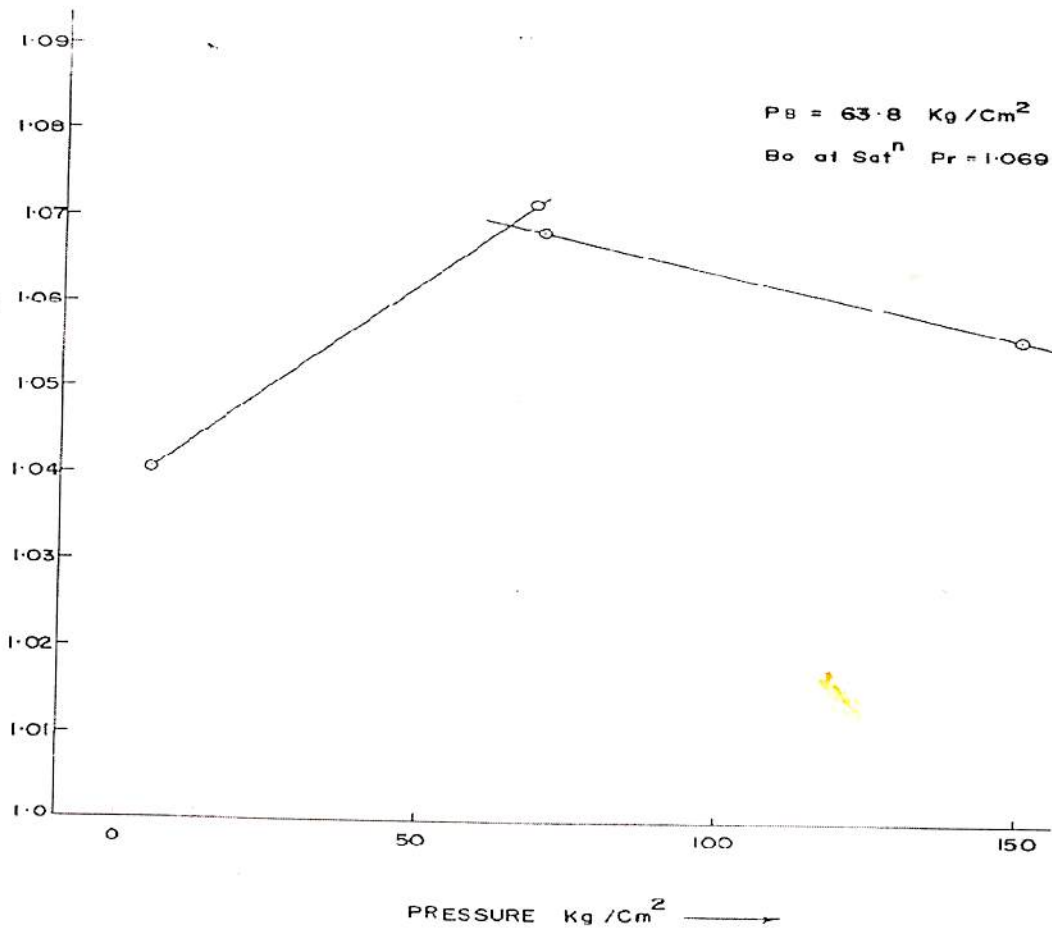

Figure- 8(f) Pressure Vs B_0 (Sand I And Sand II)

Pressure Vs Bo Sand III + Lower sands (L.S)

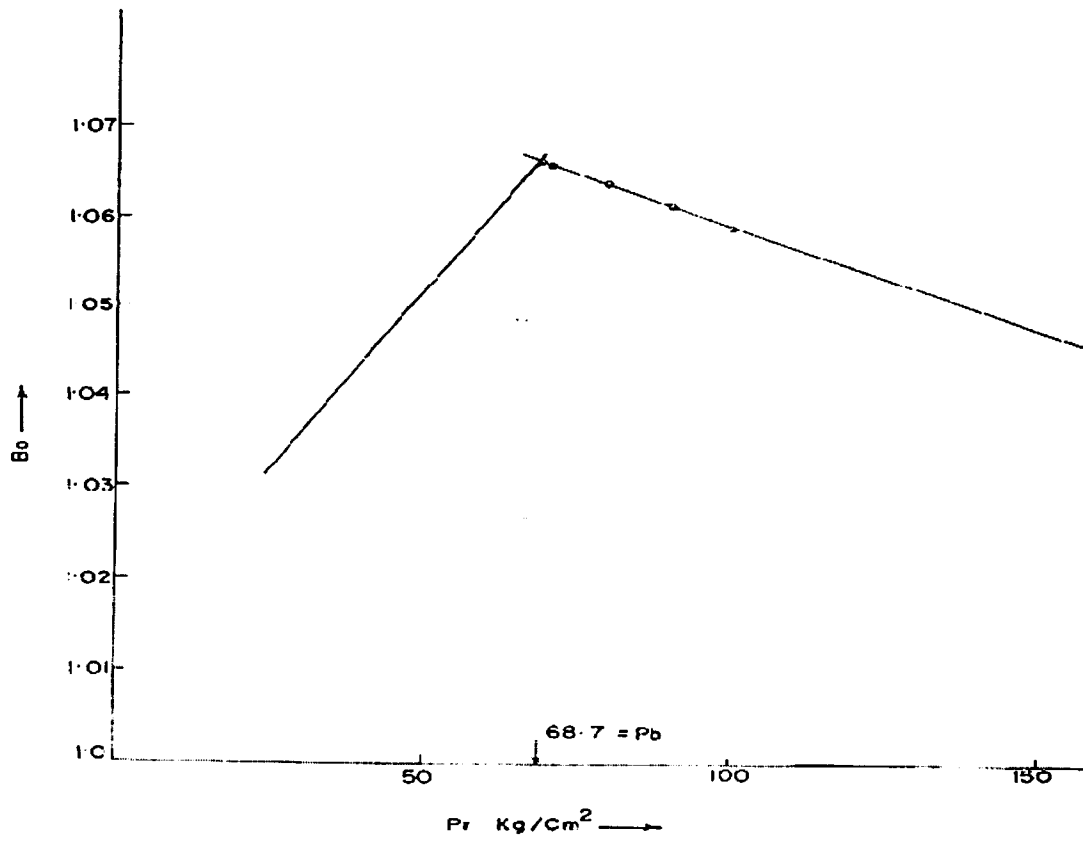

Figure- 8(g) Pressure Vs Bo Sand III + Lower sands (L.S)

Pressure Vs Viscosity (Santhal)

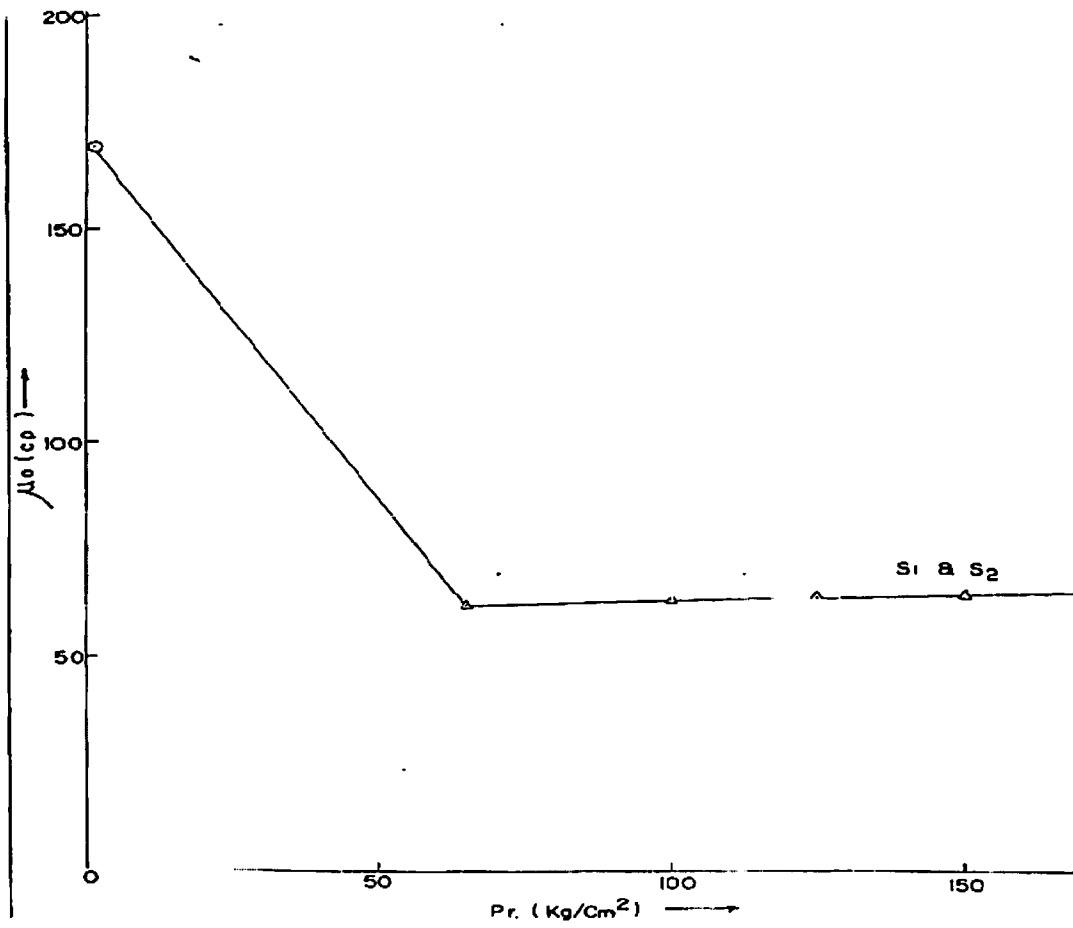

Figure- 8(h) Pressure Vs Viscosity (Santhal)

8.5 Some Properties of the reservoir:

Viscosity $\mu = 65$ cp

Bubble point pressure of sand I & sand II = 63.8 kg/cm^2

Bubble point pressure of sand III & Lower sands (L.S) = 68.7 kg/cm^2

Formation volume factor at saturation pressure, $p_b = 1.069$

Solution gas oil ratio of sand I = 15.8 V/V

Solution gas oil ratio of sand II = 16.3 V/V

Solution gas oil ratio of sand III = 19.3 V/V

Initial reservoir pressure, $p_i = 98.12 \text{ kg/cm}^2$

Due the presence of a strong aquifer the pressure decline in the reservoir is very less, also, the drive of the reservoir is a depletion drive and most important point is that throughout the life time of the reservoir the pressure of the reservoir is above bubble-point pressure.

Indicator Diagram of 300×300 m² spacing:

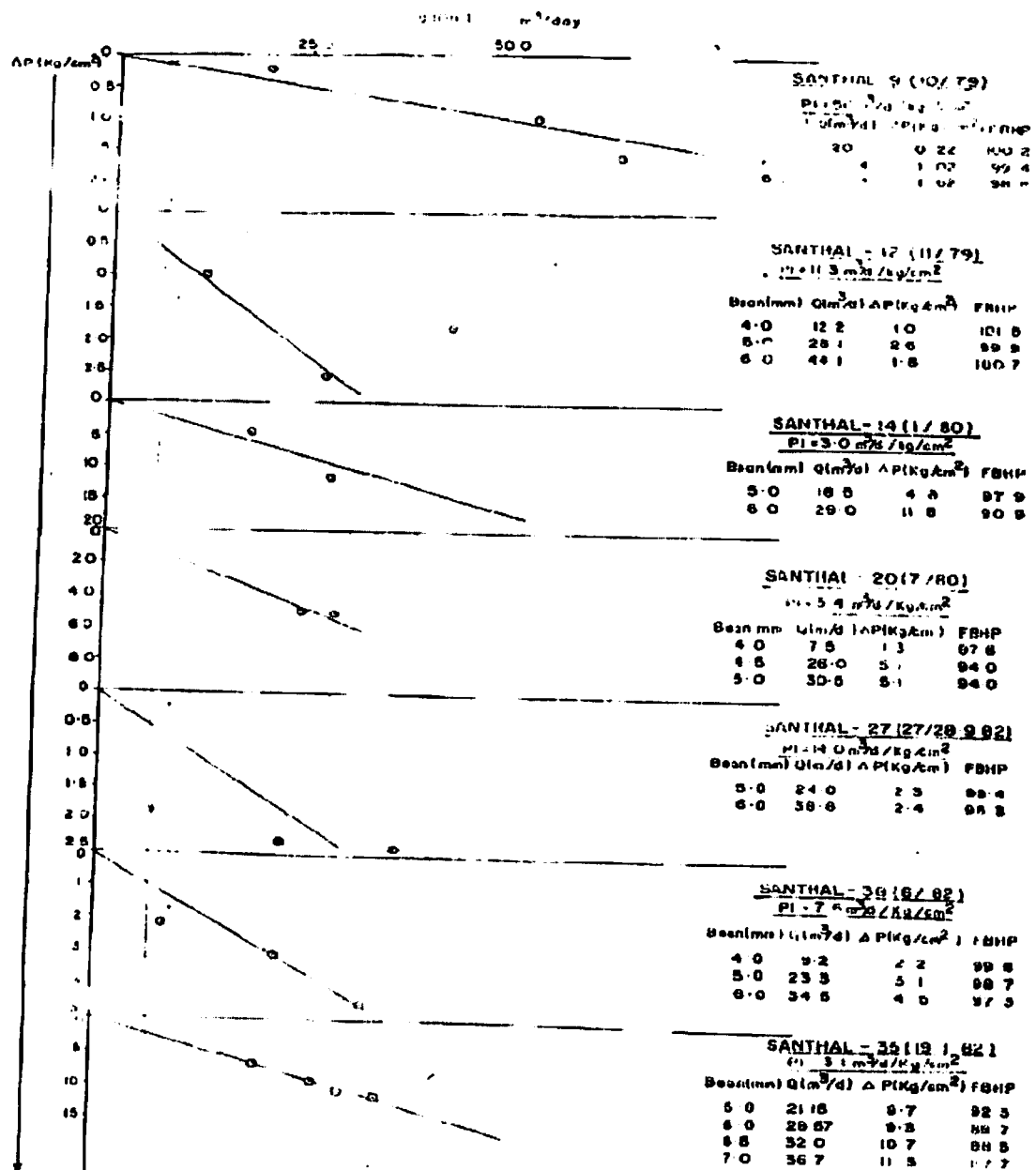

Figure- 8(i) Indicator Diagram of 300×300 m² spacing:

Indicator diagram of 250×300 m² spacing:

For well no: 9

bean (mm)	Q (m ³ /daY)	ΔP (kg/cm ²)
5	18	0.18
6	54	0.98
6.5	60	1.55

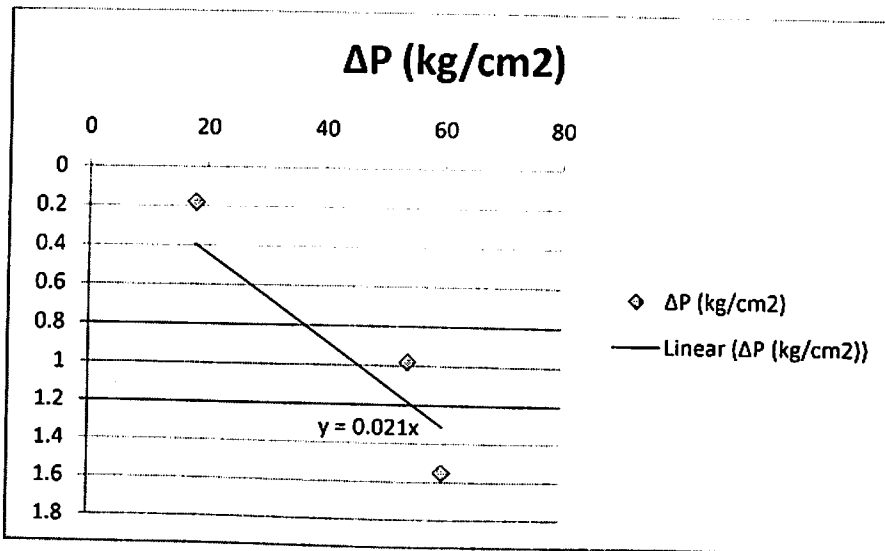

Figure- 8 (j-1) Indicator Diagram of 250×300 m² spacing for well no: 9

$$\text{Productivity index (P.I)} = \frac{1}{0.029} = 47.62 \text{ m}^3/\text{day}/\text{kg}/\text{cm}^2$$

Indicator diagram of 250×300 m² spacing:

For well no: 14

bean (mm)	Q (m ³ /day)	Δp (kg/cm ²)
5	18.5	4.2
6	29	10.8

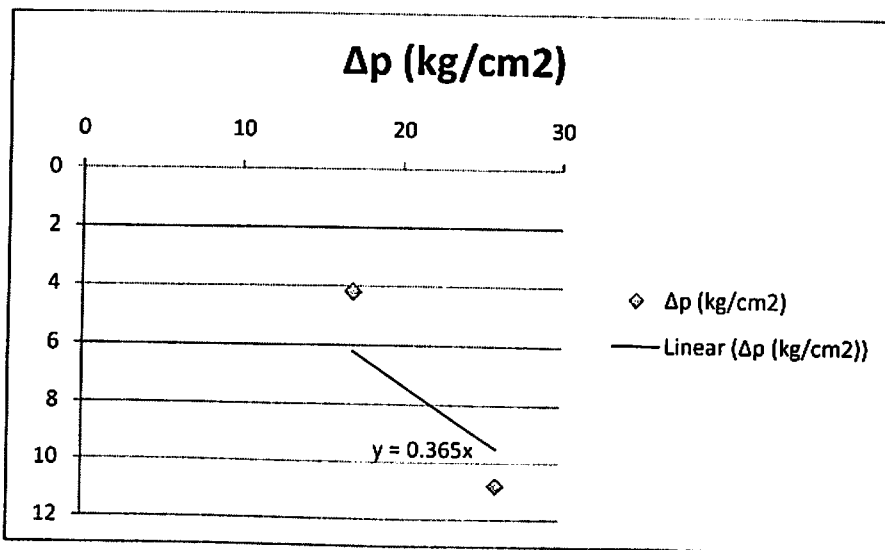

Figure- 8 (j-2) Indicator Diagram of 250×300 m² spacing for well no: 14

Productivity index (P.I) = 2.74 m³/day/kg/cm²

Indicator diagram of 250×300 m² spacing:

For well no: 38

bean (mm)	Q (m ³ /day)	Δp (kg/cm ²)
4	8.7	1.9
5	21.6	2.8
6	32.3	4.1

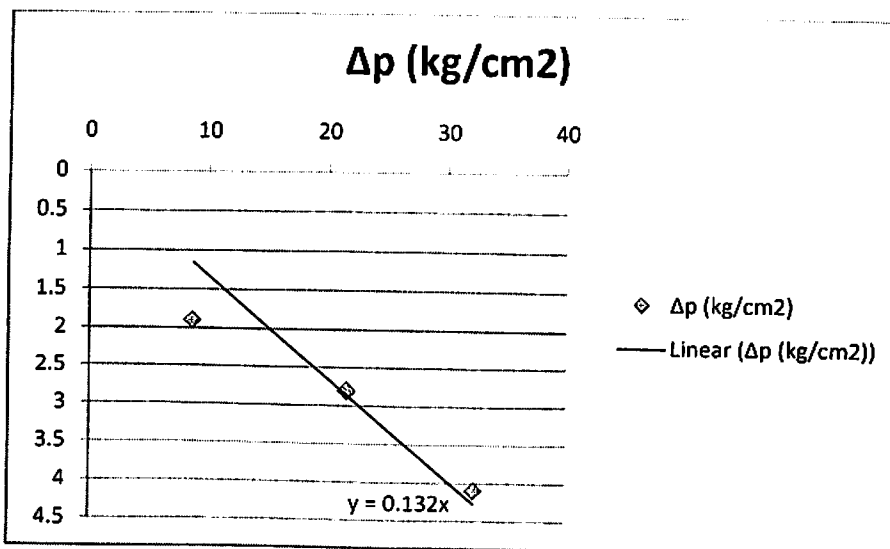

Figure- 8 (j-3) Indicator Diagram of 250×300 m² spacing for well no: 38

Productivity index (P.I) = 7.58 m³/day/kg/cm²

Indicator diagram of 250×300 m² spacing:

For well no: 35

bean (mm)	Q (m ³ /day)	Δp (kg/cm ²)
5	20.05	5.9
6	26.627	8.8
6.5	29.82	10.3
7	35.3	10.9

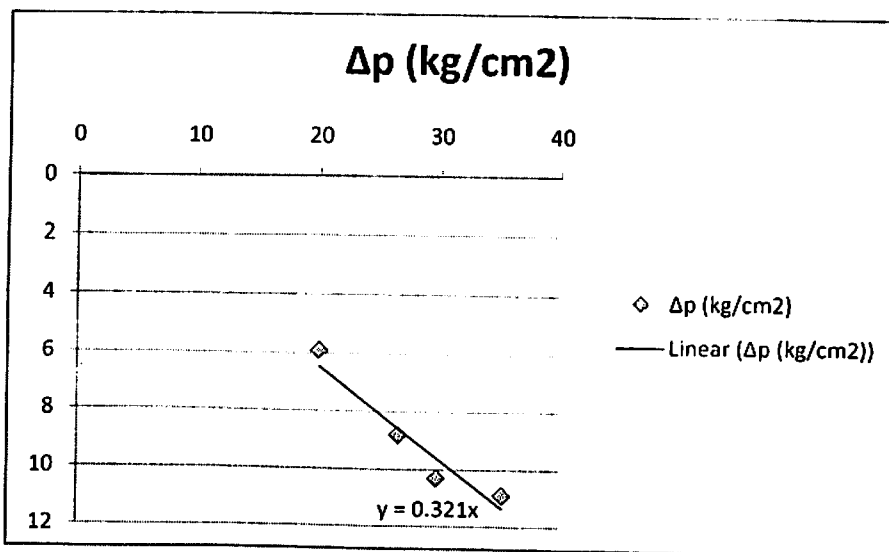

Figure- 8 (j-4) Indicator Diagrams of 250×300 m² spacing for well no: 35

Productivity index (P.I) = 3.16 m³/day/kg/cm²

Pressure Build-up plot of well no: 9

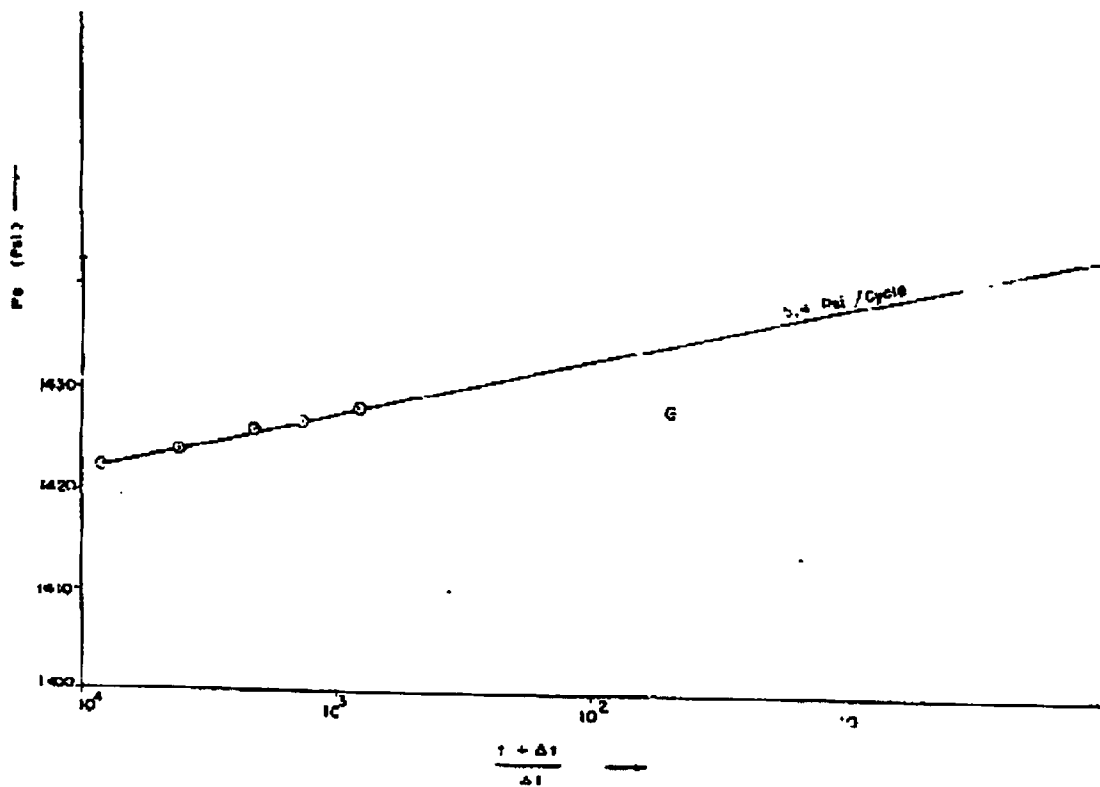

Figure- 8(k) Pressure Build-up plot of well no: 9

Pressure build-up plot of Well no14:

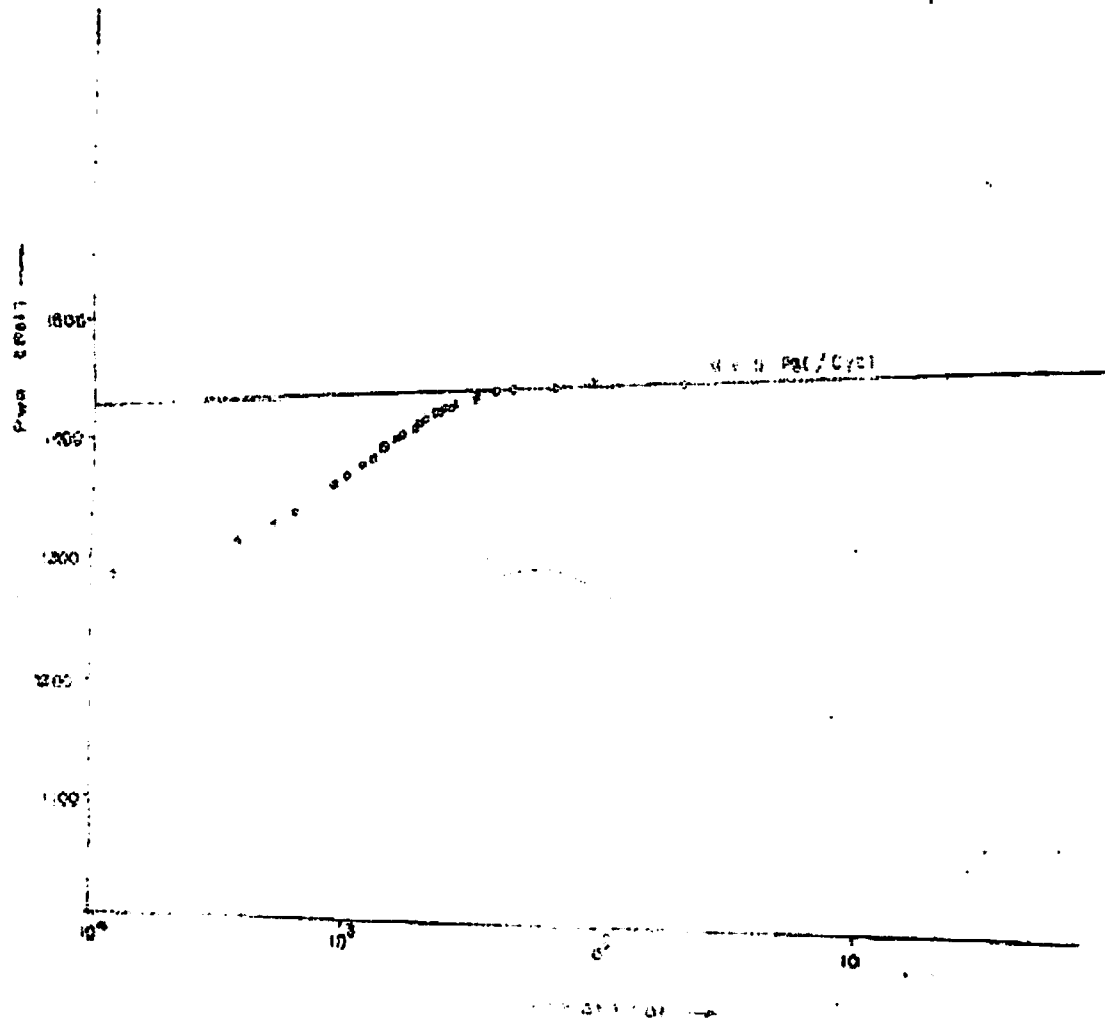

Figure- 8(1) Pressure build-up plot of Well no14

Pressure build-up plot of well no 38:

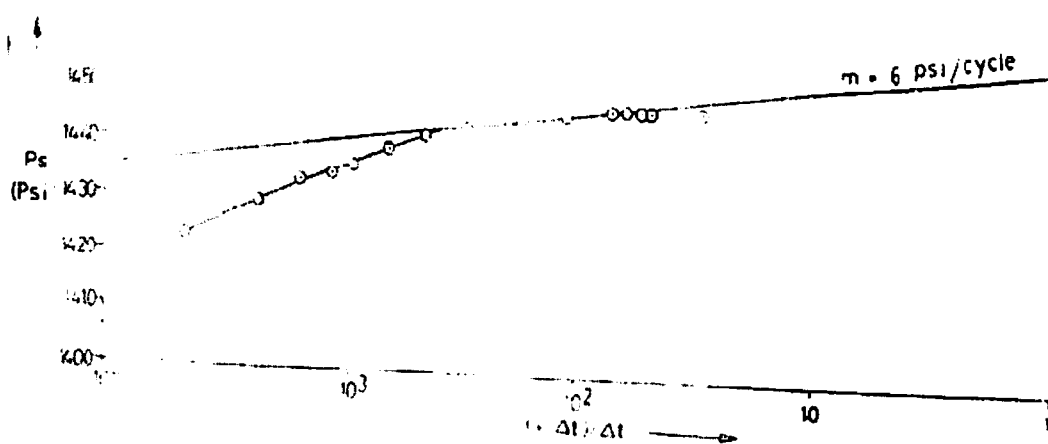

Figure- 8(m) Pressure build-up plot of well no 38

Pressure Build-up plot of well no 41

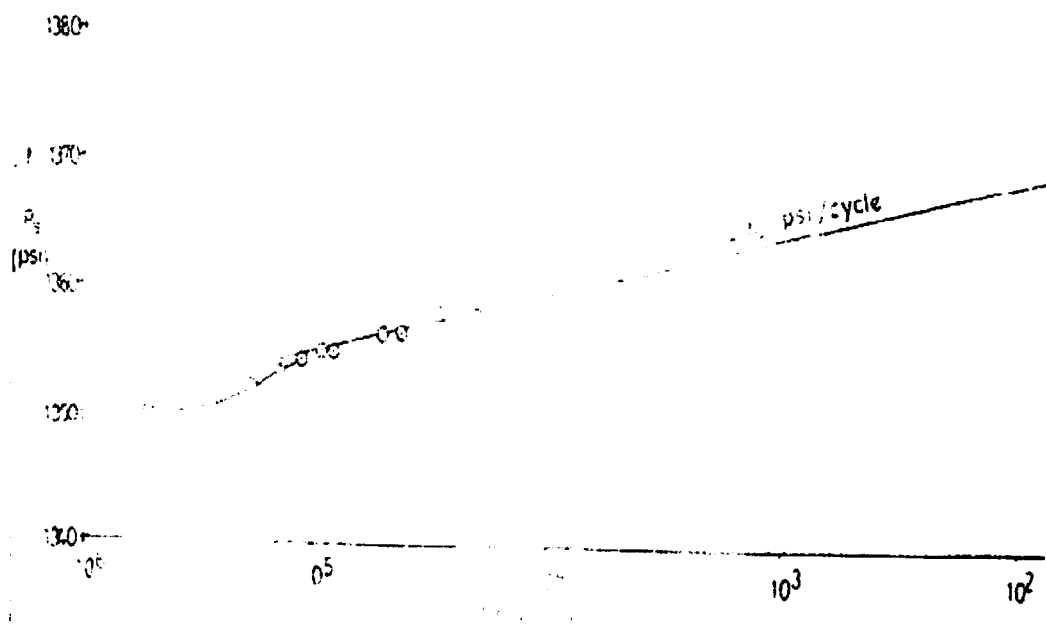

Figure- 8(n) Pressure build-up plot of well no 41

8.6 Calculation of reservoir permeability:

From above following indicator diagrams and pressure build up curves following calculations have been performed.

From fig: 8(k) for well no: 9

Slope = M = 5.4 psi/cycle

As it is a Horner's plot, slope is equal to,

$$M = \frac{2.303 b q \mu}{4 \pi K h} = 5.4 \text{ psi/cycle}$$

Also h = 22.5 mts, q = 24 m³/day

(And all other values are mentioned earlier)

$$M = \frac{5.4}{14.7} = \frac{2.303 * 1.069 * 24 * 10^6 * 65}{4 * 3.14 * K * 22.5 * 100 * 86400}$$

K = 4460 md. (Permeability)

From fig: 8(l) for well no: 14

Slope = M = 11 psi/cycle

Also h = 8.5 mts, q = 19 m³/day

After substituting all the known values in Horner's slope, we get,

K = 4404 md. (Permeability)

From fig: 8 (m) for well no: 38

Slope = M = 6 psi/cycle, h = 14 mts, q = 24 m³/day

After substituting all the known values in Horner's slope, we get,

K = 6193 md. (Permeability)

As we have discussed about two different spacing's $250 \times 300 \text{ m}^2$ and $300 \times 300 \text{ m}^2$. Now we shall see which spacing would yield better recovery.

$$\text{Productivity index} = P.I = \frac{Q}{\Delta P} = \frac{2 \times \pi \times K \times h}{B_0 \times \mu \times \ln \frac{r_e}{r_w}}$$

Case I: let the flow rate, q , be constant then from the above equation we can see that Δp is directly proportional to $\ln r_e$ and as drainage radius increases, Δp increases.

$$\Delta p = p_i - p_{wf}$$

Where,

Δp = draw down pressure, kg/cm^2

P_i = well bore pressure, kg/cm^2

p_{wf} = bottom hole flowing pressure

Which means that as drainage radius increases then the bottom hole flowing pressure decreases. Drainage radius, $\ln r_e$ is directly proportional to bottom hole-flowing pressures.

For $250 \times 300 \text{ m}^2$ well spacing the drainage radius is less than that of $300 \times 300 \text{ m}^2$ well spacing pattern.

Which in turn means that reservoir with $250 \times 300 \text{ m}^2$ spacing would require higher bottom hole pressure compared to $300 \times 300 \text{ m}^2$ well spacing at constant flow rate.

The self flowing pressure of $250 \times 300 \text{ m}^2$ would be more than $300 \times 300 \text{ m}^2$. Thus, The reservoir with $250 \times 300 \text{ m}^2$ spacing would deplete before $300 \times 300 \text{ m}^2$ well spacing patterned reservoir and thereby decreasing the ultimate recovery from a reservoir.

Case 2: let the draw down pressure, Δp , be constant then we see that flow rate, q , is inversely proportional to, $\ln r_e$.

As the drainage radius, r_e , decreases flow rate, q increases.

Thus flow rate of oil in $250 \times 300 \text{ m}^2$ spacing would be more than that of $300 \times 300 \text{ m}^2$ spacing.

Thus we conclude that out $300 \times 300 \text{ m}^2$ well spacing would yield best recovery for this reservoir.

In generally wider spacing's are not concerned because in wider spacing the wells would have greater drainage radius, r_e , but in actual drainage radius must be such that all of the oil in drainage radius must move towards the well-bore radius.

Also, the other disadvantage of wider spacing is that the reservoir would not be exploited completely and thus decreasing the ultimate recovery from the reservoir.

Since the viscosity of the field is very high staggered line drive pattern is recommended.

With increase in spacing distance the flow rate increases, ultimate recovery decreases, thereby, decreasing the life time of the reservoir and also the profit.

Well spacing for sand-I formation:

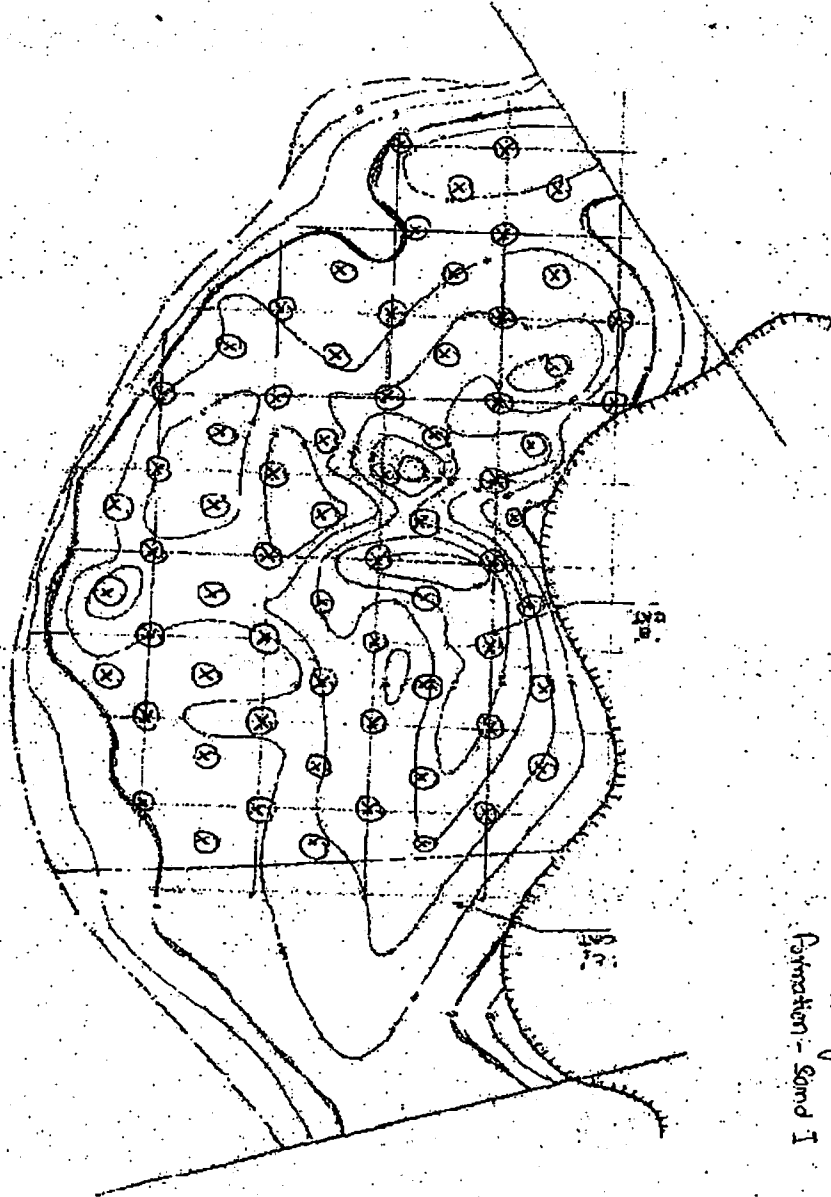

Figure-(8o-1): well spacing pattern for sand-I formation

Well spacing for sand-I formation:

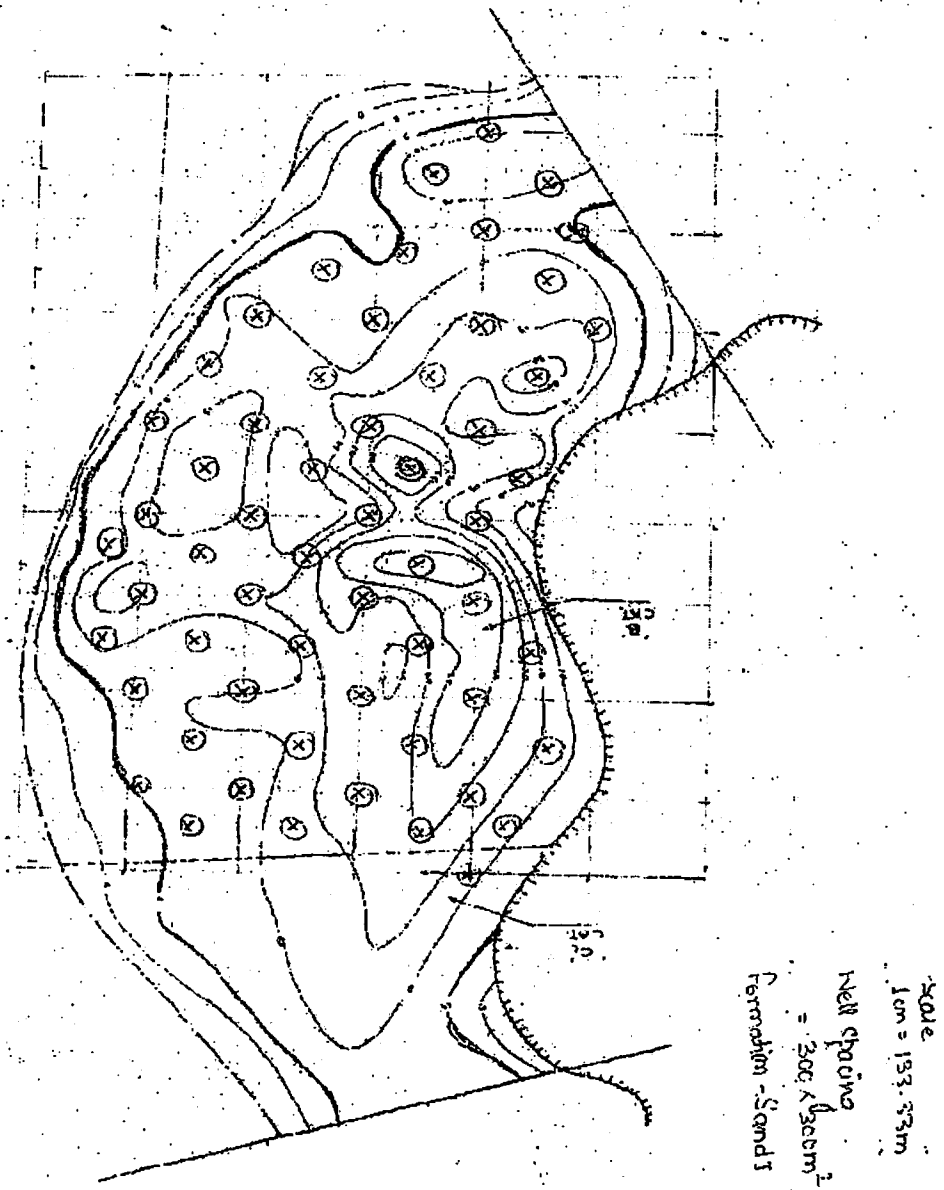

Figure-(80-2): well spacing pattern for sand-I formation

Well spacing for sand-II formation:

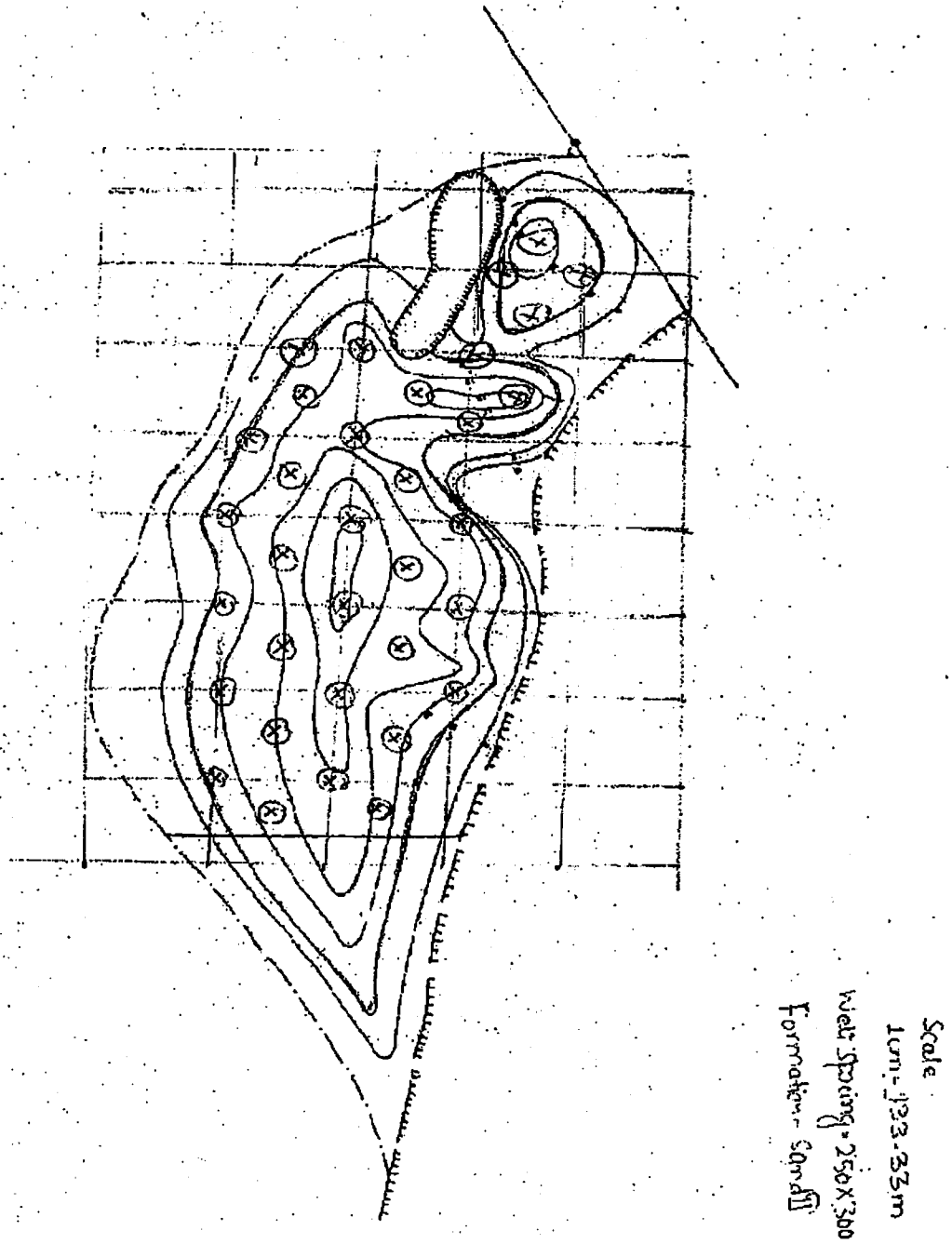
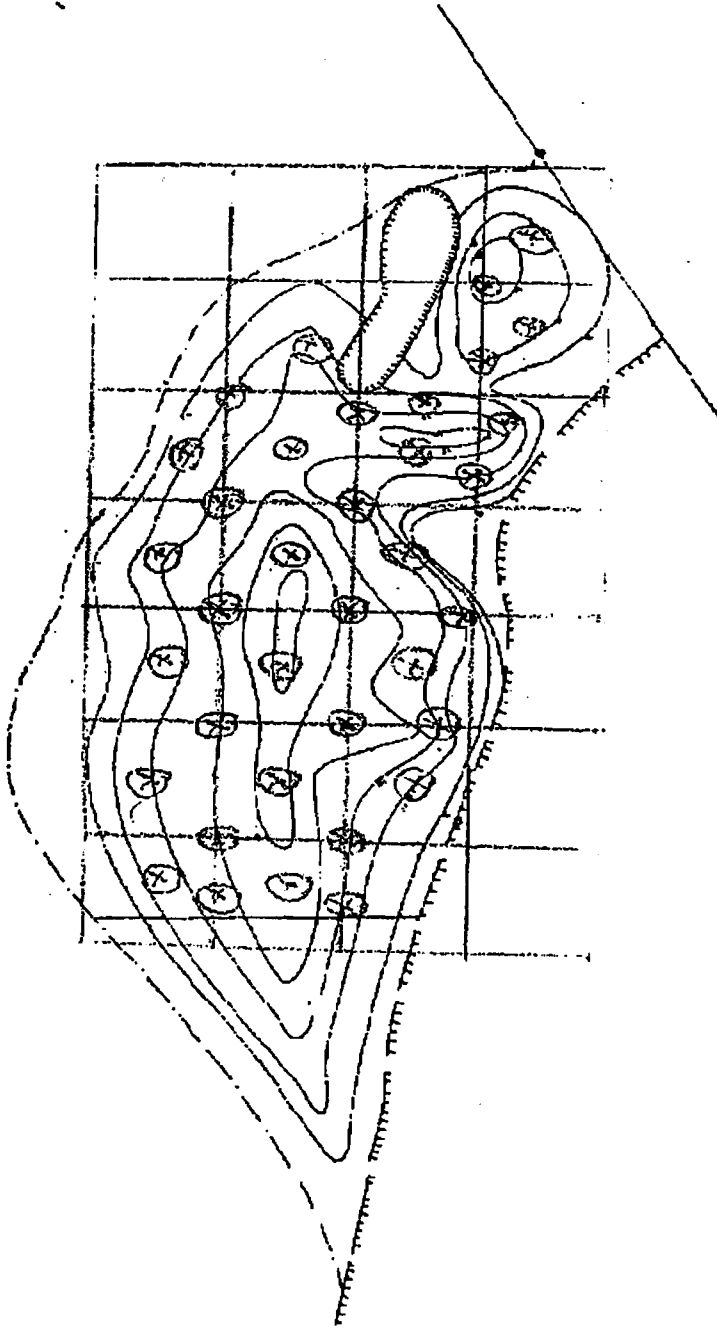

Figure-(8p-1): well spacing pattern for sand-II formation

Well spacing for sand-II formation:



Scale
1cm = 123.23m
Well spacing = 300 x 300m
Formation = Sand II

Figure-(8p-2): well spacing pattern for sand-II formation

Well spacing for sand-III formation:

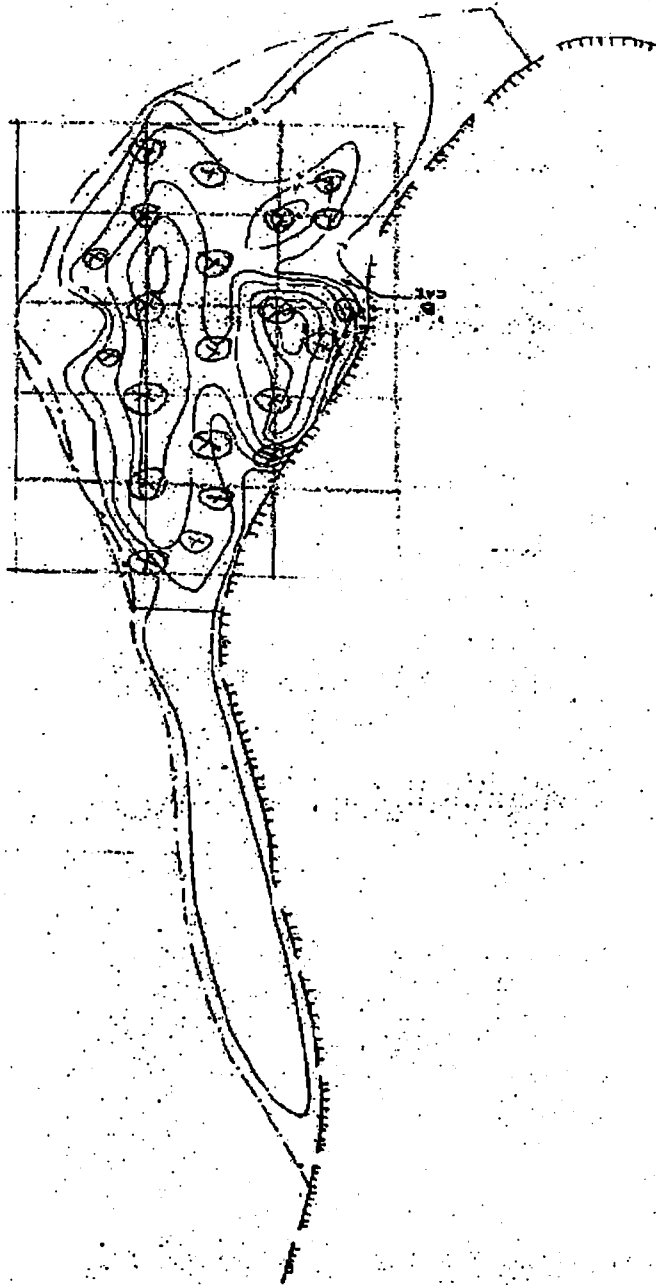

Scale
1 cm = 133.33 m
Well spacing - 270x300 m²
Formation - sand III

Figure-(8q-1): well spacing pattern for sand-III formation

Well spacing for sand-III formation:

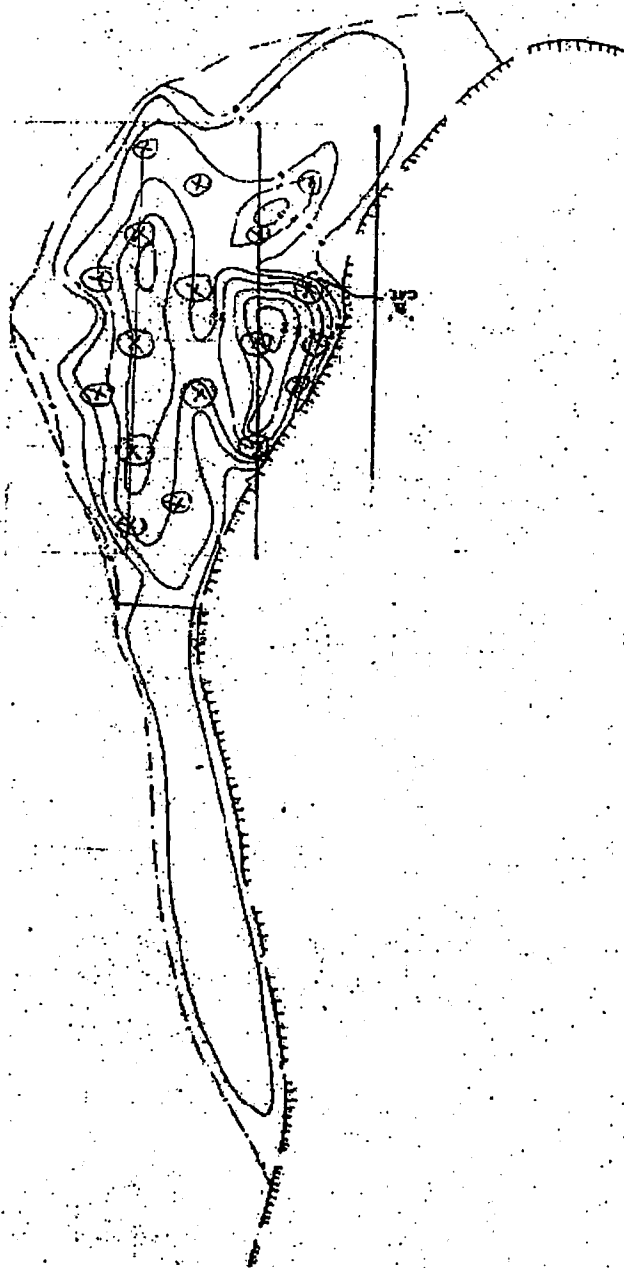

Scale
1cm = 150-300 m
Well spacing - 500x300
Formation - sand III

Figure-(8q-2): well spacing pattern for sand-III formation

Average flow rate of sand I formation is:

$$q = \frac{2 \pi K h \Delta P}{B_o \mu \ln \frac{r_e}{r_w}} \dots \dots \dots (8.1)$$

For 300×300m² well's spacing:

Where, K= 5000 md (Average value); h = 13.5 mts (Average value); B_o= 1.069;

ΔP = 2.5 kg/cm²; μ = 65 cp; r_e = 150 m (for 300×300 m² spacing); r_w = 3.5 cm

Substituting all the above values in equation (8.1), we get

$$q = 182.37 \text{ cm}^3/\text{sec} = 15.76 \text{ m}^3/\text{day} \text{ (sand I formation)}$$

For sand II formation, q = 13.39 m³/day and for sand III formation, q = 11 m³/day

For 250×300 m² well's spacing:

All the parameters are same expect that r_e = 125 m; ΔP = 2.0 kg/cm²

q = 12.9 m³/day (sand I formation)

q = 10.95 m³/day (sand II formation)

q = 9.02 m³/day (sand III formation)

From the above graphs:

250×300 m² well's-spacing pattern:

Formation	Num: of wells	Flow rate per- well Q (m ³ /day)	Annual flow rate per-well Q (m ³ /yr)	Total flow rate of the reservoir (m ³ /yr)	Flow rate after Efficiency factor (0.8) (m ³ /yr)
Sand I	58	12.9	4,708.5	2,73,093	2,18,474
Sand II	31	10.95	3,996.75	1,23,899.25	99,119.4
Sand III	13	9.02	3,292	42,796	34,236.8
Total =				4,39,788.25	3,51,830.2

300×300 m² well's-spacing pattern:

Formation	Num: of wells	Flow rate per-well Q(m ³ /day)	Annual flow rate Per well Q (m ³ /yr)	Total flow rate of the reservoir (m ³ /yr)	Flow rate after Efficiency factor (0.8) (m ³ /yr)
Sand I	47	15.76	5,752.4	2,70,362.8	2,16,290.25
Sand II	32	13.39	4,887.35	1,56,395.2	1,25,116
Sand III	14	11	4,015	56,210	44,968
Total =				4,82,968	3,86,374.25

*efficiency factor of the reservoir is taken to be 80%

From above two tables we see that 300×300 m² spacing would yield better recovery than 250×300 m² spacing.

In generally, different spacing patterns are tried for a reservoir and then from each well-spacing pattern ultimate recovery and techno-economic variant are calculated. The pattern with highest recovery and better profit will be selected.

Well spacing's are given in the beginning of the exploratory drilling program, after a careful study of the reservoir rock and fluid properties, configuration of the reservoir...etc.

VOLUMETRIC RESERVE CALCULATION:

$$G = \frac{7758 V_b \Phi (1 - S_w)}{B_o}$$

Bulk volume calculated through contour maps of:

Sand I formation; V_b: 7400 ac-ft

Sand II formation; V_b: 5000 ac-ft

Sand III formation; V_b: 3330 ac-ft

$$O.I.I.P = \frac{7758 \times 7400 \times 0.2 \times 0.75}{1.069} = 8.056 \times 10^7 \text{ bbl (Sand I formation)}$$

$$O.I.I.P = \frac{7758 \times 5000 \times 0.2 \times 0.75}{1.069} = 5.443 \times 10^7 \text{ bbl (Sand II formation)}$$

$$O.I.I.P = \frac{7758 \times 3330 \times 0.2 \times 0.75}{1.069} = 3.6265 \times 10^7 \text{ bbl (Sand III formation + Lower sands)}$$

Chapter 9: CONCLUSION

If accepts the foregoing presentation of evidence the drainage can occur over great distances within a continuous reservoir and the, further, the ultimate recovery is independent of the physical distance between wells, then the determination of the well spacing program for a reservoir primarily rest upon the following considerations:

1. Sufficient wells must be drilled to provide adequate geological data, structural configuration of the reservoir, the continuity and characteristics of reservoir rock, and the total amounts of oil, gas and water contained in the reservoir.
2. Sufficient wells must be drilled to drain the reservoir adequately under the type of drive operative and to permit effective control of the recovery mechanism throughout the entire process.
3. Only sufficient number of wells must be provided that are physically capable of withdrawing oil at maximum rate to be produced from the reservoir under the available or chosen recovery mechanism. This number of wells further should be sufficient to produce this total volume of oil from the reservoir without incurring inefficient well performance in the form of local excessive disturbance in reservoir pressure that might cause local variations in the dominant recovery mechanism or would lead to irregular advance of gas or water through channeling, fingering, or coning.

It is recognized that in many reservoirs the variations in lease ownership and the right of individual operators to share proportionately in the field production have introduced complicating factors in securing a proper spacing program for each individual field. The drilling of unnecessary wells in many fields has resulted from these factors, and in some instances excessive wells have actually lead to wasteful production practices. A sound well-spacing pattern, coupled with a sound allocation program, however, is possible through acquisition and interchange of knowledge and through co-operative effort to eliminate the unnecessary well.

REFERENCES

1. "Dr. Kumar, Sant"-Development of Oil and Gas Fields.
2. "Dr. kumar , sant"- Testing of oil and gas wells & its analysis.
3. "LEVERSON, A.I."- "Geology of Petroleum", W.H. Freeman and Company, Inc.,san Francisco,1954.
4. Amyx, James W, Bass, Daniel M. Jr., and Whiting Robert, L- "Petroleum Reservoir Engineering- Physical Properties" McGraw- Hill Book Company, New York, 1960.
5. Craft and Hawkins- "Applied Petroleum Reservoir Engineering" Prentice-Hall Inc.,Englewood Cliffs NJ(USA).
6. "Dake, L.P"- Fundamentals of reservoir Engineering . Elsevier, 1978
7. "Thomas, C. Frick"- Reservoir Engineering Vol-II, Society of Petroleum Engineers of AIME, Dalls , Texas.
8. "Pirson, S.J"- Oil Reservoir Engineering, Mcgraw- Hill Book Company, Inc., NewYork, 1958.
9. "Nind, TEW"- Principles of Oil Well Production, Mcgraw-Hill Book Company Inc., NewYork
- 10."Ahmed, Tarek"- Reservoir Engineering Handbook.
- 11."Serra. O,"-Fundamentals of well log Interpretation, ELSEVIER SCIENCE PUBLISHING COMPANY INC, New York, NY 10017, U.S.A.
- 12."Darling ,Toby" - Well Logging & Formation Evaluation, Elsevier Inc.,2005

13. "Schlumberger,." - log interpretation Principles/application, Schlumberger 1991
14. "Pinczewski, Val."- RESERVOIR ENGINEERING - Part A, School of Petroleum Engineering University of New South Wales, AUSTRALIA, January, 2007.
15. "Pinczewski, Val."- Reservoir Simulation, School of Petroleum Engineering University of New South Wales, AUSTRALIA, January, 2007.
16. "John, Lee"- Well Testing.
17. "Amanat, U. Chaudhry"- Oil Well Testing Handbook, Elsevier Inc.
18. "Karen, Schou, Pederson", "Peter, L. Christensen"- Phase Behaviour of Petroleum reservoir fluids, Taylor and Francis Group, LLC.
19. "Bath"- Introduction to Well Testing, England, March 1998.
20. "Papay, Jozsef"- Development of petroleum reserves.