

Name:

Enrolment No:



UNIVERSITY OF PETROLEUM AND ENERGY STUDIES

End Semester Examination, July 2020

Programme Name: B.Tech Mechanical

Course Name : Fluid Mechanics and Machines

Course Code : MECH2026

Semester : IV

Time : 03 hrs

Max. Marks : 100

Instructions:

- Section A constitutes of 20 Marks (4 questions x 5 marks); Attempt All.
- Section B constitutes of 40 Marks (4 questions x 10 marks). Attempt All (One choice question).
- Section C constitutes of 40 Marks (2 questions x 20 marks). Attempt All (One choice question).

SECTION A

SN			CO
Q1		5	CO1
Q 2	It is desired to record the variation of the pressure at an interval of every 0.5 second inside an IC Engine. Suggest a strategy to take these measurements.	5	CO1
Q 3	Read these statements and answer the question that follow Mohan: Forced vortex is rotational. Murari: Free Vortex is irrotational. MadanMohan: Free Vortex is rotational. Madhusudan: Forced Vortex is irrotational. Madhava: Forced and Free Vortex are irrotational. MuraliMohan: Forced and Free Vortex are Rotational. Who is/are correct? Justify your answer with examples.	5	CO1
Q 4	Imagine you are a pilot of a Boeing 757 Jet commercial aircraft. While flying this aircraft, when (and why) would you use: <ul style="list-style-type: none">• Leading edge slats• Trailing edge flaps	5	CO1

SECTION B

Q 5

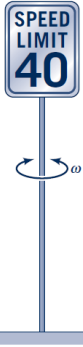

Under certain conditions, wind blowing past a rectangular speed limit sign can cause the sign to oscillate with a frequency ν . Assume that ν is a function of the sign width, b , sign height, h , wind velocity, V , air density, ρ , and an elastic constant, k , for the supporting pole. The constant, k , has dimensions of FL . Develop a suitable set of pi terms for this problem.

10

CO2

Q 6

Determine the gage pressure in kPa at point a , if liquid A has $SG = 1.20$ and liquid B has $SG = 0.75$. The liquid surrounding point A is water, and the tank on the left is open to the atmosphere.

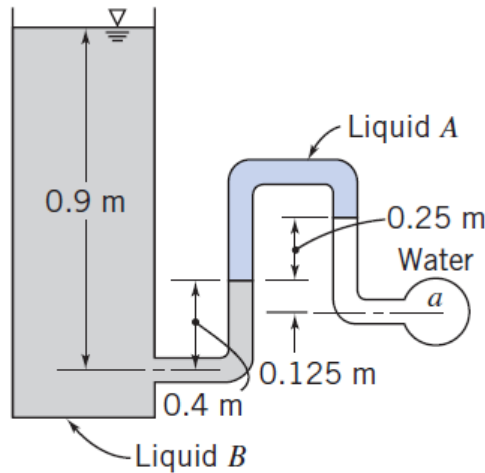

OR

The Pelton turbine at Seera de Cubatao (Brazil) is a double overhung, two nozzle, horizontal type and develops 85,000 HP under a head of 710 m. Determine its specific speed, provided that the electricity production in Brazil is at same frequency as India.

10

CO2

Q 7

The pressure at section (2) shown in Fig. P8.73 is not to fall below 60 psi when the flowrate from the tank varies from 0 to 1.0 cfs and the branch line is shut off. Determine the minimum height, h , of the water tank under the assumption that minor losses are not negligible.

10

CO4

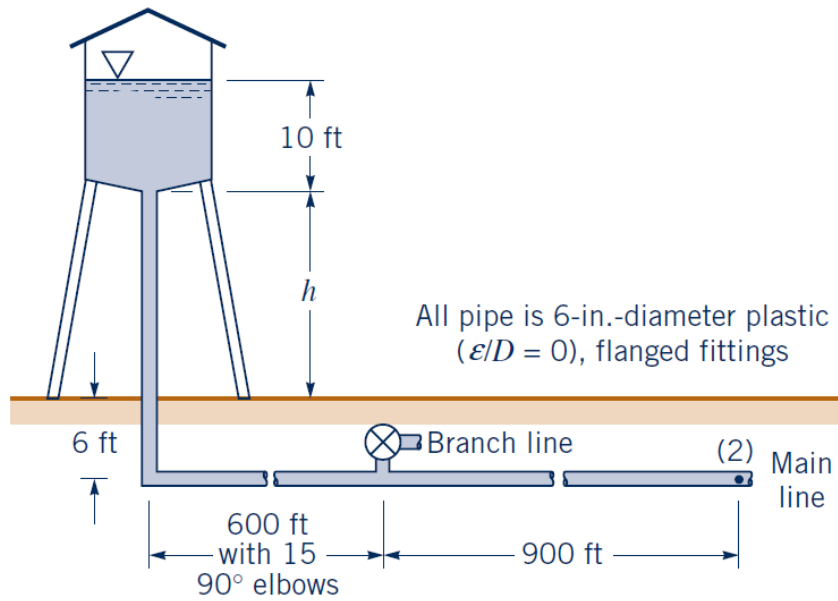

Q 8 The velocity profile in a hypothetical boundary layer is approximated by the power law equation

$$\frac{u}{U} = \left(\frac{y}{\delta}\right)^{1/6}$$

- a) Find displacement thickness.
- b) Find momentum thickness.
- c) Compare the case of turbulent BL with Laminar BL.

10 CO3

SECTION C

Q 9 According to a recent report by National Renewable Energy Laboratory (NREL), there is an average wind speed below $\sim 3\text{m/s}$ in Uttarakhand at heights of 80-100 m and a wind density of $\rho \text{ kg/m}^3$. Assuming Uttarakhand Council of Science and Technology (UCOST) plans to install a single horizontal-axis wind turbine (shown) with the following specifications:

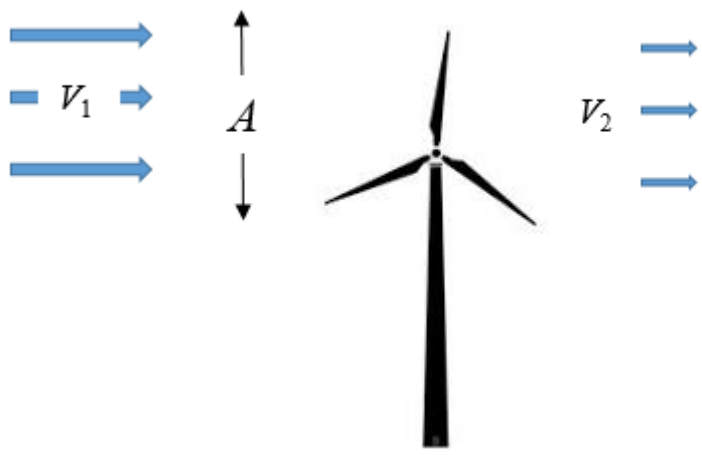

20 CO4

a) Let the total incident power in the wind over the span area of the turbine be denoted by P_1 (dependent upon V_1). **Express P_1** as a function of V_1 .

b) Express mass flow rate through the span area of wind turbine, **using the velocity obtained by taking the mean** of the incident (V_1) and exit velocities (V_2).

c) The total power extracted by the turbine, P can be described as the change in rate of kinetic energy before and after it has passed through blades. Use the mass flow rate obtained in part (b).

d) Get an expression for P/P_1 as a function of V_2/V_1 .

e) What is the maximum possible value of P/P_1 ?

OR

Find the force exerted on the plate in the given situation below

(a) Plate velocity in a direction normal to the plate

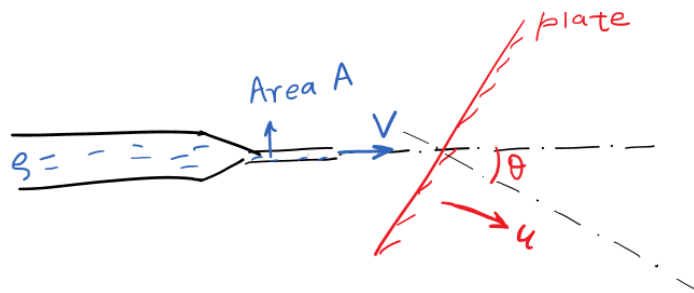

(b) plate velocity being vertical

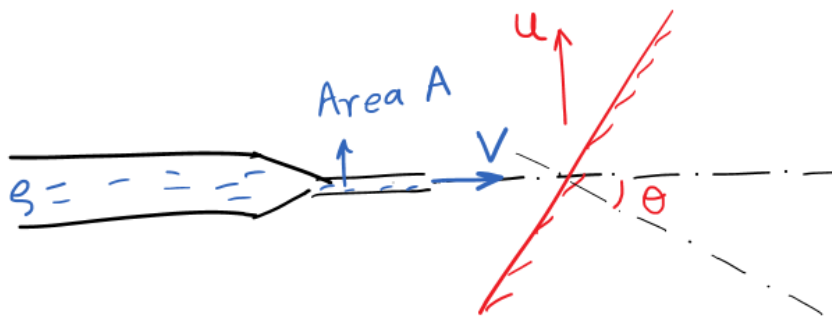

(c) plate velocity is horizontal.

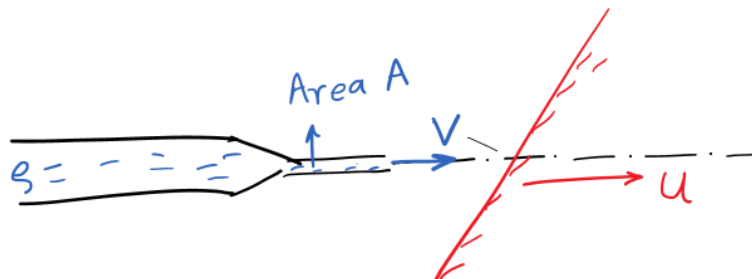

The inlet water velocity corresponding to the hydropower plant is 100 m/s and the blade (flat plate, in our case) velocity at the centerline is 60 m/s. Answer these:

- Is there a single case, which is best, as far as the **net** force is concerned, irrespective of θ , at the minimum blade velocity?
- If the answer to the above question is yes, is there a clear second best, irrespective of all values of θ , at the minimum blade velocity?

Q 10 A tornado (shown on the left) can be modeled by the superposition of a sink of strength 3000 m²/s and a free vortex of circulation 6000 m²/s. Further, the stream function and velocity potentials for some basic potential flows are shown below:

Description of Flow Field	Velocity Potential	Stream Function	Velocity Components ^a
Uniform flow at angle α with the x axis (see Fig. 6.16b)	$\phi = U(x \cos \alpha + y \sin \alpha)$	$\psi = U(y \cos \alpha - x \sin \alpha)$	$u = U \cos \alpha$ $v = U \sin \alpha$
Source or sink (see Fig. 6.17) $m > 0$ source $m < 0$ sink	$\phi = \frac{m}{2\pi} \ln r$	$\psi = \frac{m}{2\pi} \theta$	$v_r = \frac{m}{2\pi r}$ $v_\theta = 0$
Free vortex (see Fig. 6.18) $\Gamma > 0$ counterclockwise motion $\Gamma < 0$ clockwise motion	$\phi = \frac{\Gamma}{2\pi} \theta$	$\psi = -\frac{\Gamma}{2\pi} \ln r$	$v_r = 0$ $v_\theta = \frac{\Gamma}{2\pi r}$
Doublet (see Fig. 6.23)	$\phi = \frac{K \cos \theta}{r}$	$\psi = -\frac{K \sin \theta}{r}$	$v_r = -\frac{K \cos \theta}{r^2}$ $v_\theta = -\frac{K \sin \theta}{r^2}$



- For the tornado shown above, determine :
- The expression for velocity potential.
 - The expression for stream function.
 - The radial and tangential velocities
 - The radius beyond which the flow is incompressible.
 - Find the gauge pressure at that radius

20 CO3

Appendix

Haaland Equation

$$\frac{1}{\sqrt{f}} = -1.8 \log \left[\frac{6.9}{Re} + \left(\frac{\epsilon/D}{3.7} \right)^{1.11} \right]$$

Name:

Enrolment No:



UNIVERSITY OF PETROLEUM AND ENERGY STUDIES

End Semester Examination, May 2020

Programme Name: B.Tech Mechanical

Semester : IV

Course Name : Fluid Mechanics and Machines

Time : 03 hrs

Course Code : MECH2026

Max. Marks : 100

Instructions:

- Section A constitutes of 20 Marks (4 questions x 5 marks); Attempt All.
- Section B constitutes of 40 Marks (4 questions x 10 marks). Attempt All (One choice question).
- Section C constitutes of 40 Marks (2 questions x 20 marks). Attempt All (One choice question).

Please answer the sub-parts of a question together. Highlight the numerical answers.

SECTION A

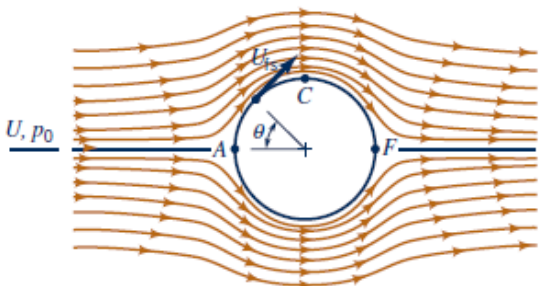
S. No.			CO
Q 1	<p>Read these statements and answer the question that follow</p> <p>Raghav: All inviscid flows are irrotational. Raghunath: All irrotational flows are inviscid. Raghuram: All viscous flows are rotational. Raman: All viscous flows are irrotational. Ramesh: All irrotational flows are inviscid.</p> <p>Who is/are correct? Justify your answer with examples. (None/All of the choices may also be correct)</p>	5	CO1
Q 2	<p>A European Fluid Dynamicist, D' Alambert, once observed to his great surprise that</p>  <p>1) For $\mu = 0$, Drag Force $F_D = 0$ 2) For $\mu \sim 0$, Significant drag force F_D 3) As μ is increased, F_D is independent of μ.</p> <p>How do you explain such strange observations?</p>	5	CO1
Q 3	<p>Why is it that sometimes on narrow industrial Chimneys, spirals are made on the circumference? What specific purpose do they serve? Explain the underlying phenomenon.</p>	5	CO1
Q 4	<p>Citing the specific example of the recently launched <i>Speedtail MaLaren</i> sports car, enumerate what specific features can be had on a high speed car, to enable it to attain extremely high speeds? Present only the Fluid Mechanics perspectives.</p>	5	CO1

SECTION B

Q 5 A cylinder with a diameter D floats upright in a liquid as shown in the figure. When the cylinder is displaced slightly along its vertical axis it will oscillate about its equilibrium position with a frequency, ν . Assume that this frequency is a function of the diameter, D , the mass of the cylinder, m , and the specific weight, γ , of the liquid. Determine, with the aid of dimensional analysis, how the frequency is related to these variables. If the mass of the cylinder were increased, would the frequency increase or decrease?

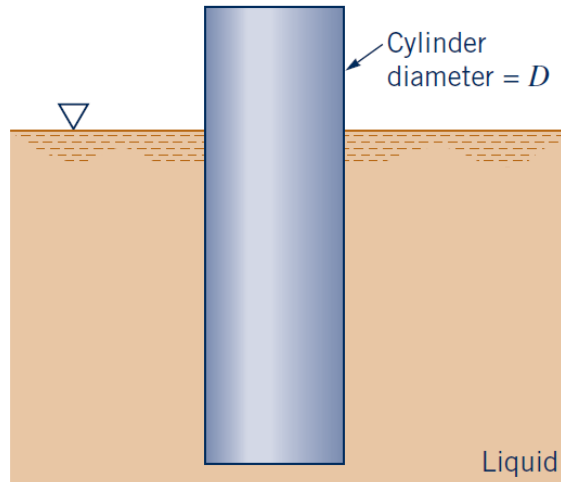

10 CO2

Q 6 For flow over a hypothetical flat plate of length L , the velocity profile can be approximated as

$$\frac{u}{U} = 0.7 \frac{y}{\delta}$$

Find:

- a) Boundary layer thickness at a distance x .
- b) Shear stress at a distance x
- c) Local drag coefficient
- d) Coefficient of Drag

10 CO2

Q 7 A partitioned tank as shown contains water and mercury. What is the gage pressure in the air trapped in the left chamber? What pressure would the air on the left need to be pumped to in order to bring the water and mercury free surfaces level?

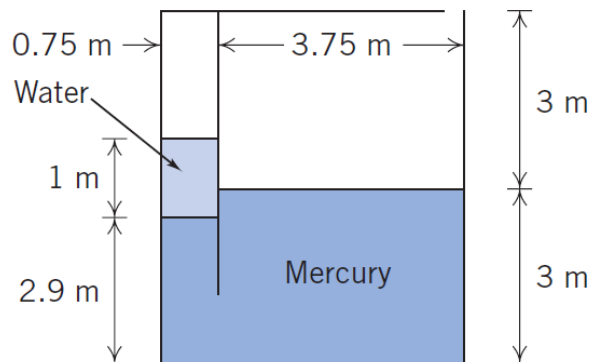

10 CO3

OR

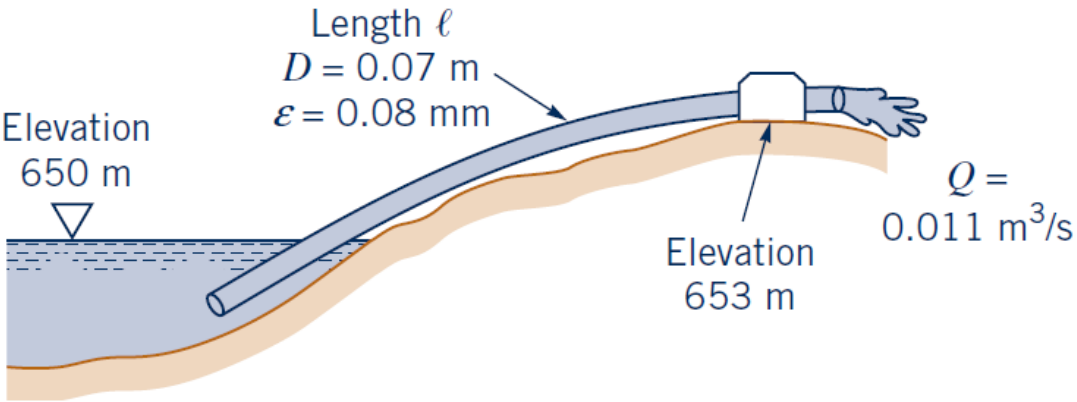
	<p>It is proposed to develop 2000 HP at a site where 150 m of head is available. What type of turbine would be employed if it had to run at 300 rpm?</p> <p>If the power requirements are stringent, but a compromise is possible to be made between N and H, Can you suggest alternative values of N, which are possible? How does the N-vs-H curves appear?</p>		
Q 8	<p>Water at 20 deg C is pumped from a lake as shown in the figure. If the flowrate is 0.011 m³/s, what is the maximum length inlet pipe, L, that can be used without cavitation occurring?</p>  <p>The diagram shows a pipe of length ℓ and diameter $D = 0.07$ m with roughness $\epsilon = 0.08$ mm. The pipe is drawn from a lake at an elevation of 650 m to a pump at an elevation of 653 m. The flow rate Q is 0.011 m³/s.</p>	10	CO4
SECTION C			
Q 9	<p>Using Continuity and Navier-Stokes Equation in cylindrical coordinates for fluid flow through a pipe, derive expressions for</p> <ol style="list-style-type: none"> Velocity profile in a pipe of diameter D Relationship between discharge and pressure drop over length L of this pipe. 	20	CO3
Q 10	<p>According to a recent report by National Renewable Energy Laboratory (NREL), there is an average wind speed below ~3m/s in Uttarakhand at heights of 80-100 m and a wind density of ρ kg/m³. Assuming Uttarakhand Council of Science and Technology (UCOST) plans to install a single horizontal-axis wind turbine (shown) with the following specifications:</p>	20	CO4

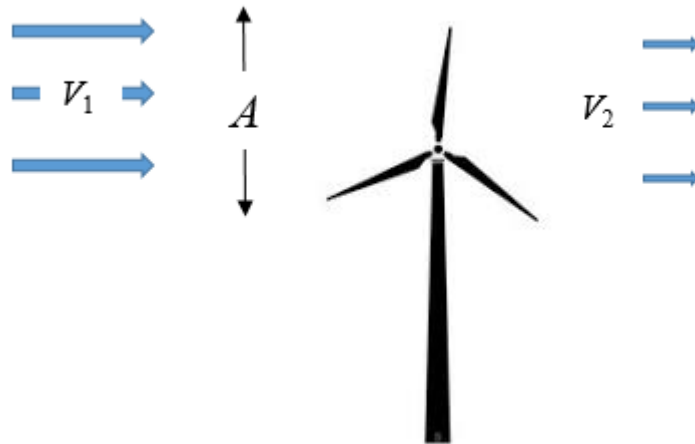

- Let the total incident power in the wind over the span area of the turbine be denoted by P_1 (dependent upon V_1). **Express P_1** as a function of V_1 .
- Express mass flow rate through the span area of wind turbine, **using the velocity obtained by taking the mean** of the incident (V_1) and exit velocities (V_2).
- The total power extracted by the turbine, P can be described as the change in rate of kinetic energy before and after it has passed through blades. Use the mass flow rate obtained in part (b).
- Get an expression for P/P_1 as a function of V_2/V_1 .
- What is the maximum possible value of P/P_1 ?

OR

Answer these questions on the design of Pelton Wheels:

- The highest head so far used anywhere in the world till date is for running a Pelton turbine, installed at REISSECK (Austria) which is rated as 31, 400 BHP at 750 rpm under an effective head of 1770 meters. Determine the least diameter of jet, the mean diameter of Pelton runner and the number of buckets of Pelton runner (Use Dr. Taygun's expression). Assume suitable values of speed coefficients and the turbine efficiency etc.
- Design a Pelton turbine with the following data:
Head of water = 305 m; Rate of flow = 240 liters/sec; Speed of turbine = 750 rpm
Assume suitable constants.

Appendix

Haaland Equation

$$\frac{1}{\sqrt{f}} = -1.8 \log \left[\frac{6.9}{Re} + \left(\frac{\varepsilon/D}{3.7} \right)^{1.11} \right]$$

Conservation Equations in Cylindrical Coordinates:

Continuity Equation:

$$\frac{\partial \rho}{\partial t} + \frac{1}{r} \frac{\partial (r \rho v_r)}{\partial r} + \frac{1}{r} \frac{\partial (\rho v_\theta)}{\partial \theta} + \frac{\partial (\rho v_z)}{\partial z} = 0$$

Momentum Equation:

(r direction)

$$\begin{aligned} \rho \left(\frac{\partial v_r}{\partial t} + v_r \frac{\partial v_r}{\partial r} + \frac{v_\theta}{r} \frac{\partial v_r}{\partial \theta} - \frac{v_\theta^2}{r} + v_z \frac{\partial v_r}{\partial z} \right) \\ = -\frac{\partial p}{\partial r} + \rho g_r + \mu \left[\frac{1}{r} \frac{\partial}{\partial r} \left(r \frac{\partial v_r}{\partial r} \right) - \frac{v_r}{r^2} + \frac{1}{r^2} \frac{\partial^2 v_r}{\partial \theta^2} - \frac{2}{r^2} \frac{\partial v_\theta}{\partial \theta} + \frac{\partial^2 v_r}{\partial z^2} \right] \end{aligned}$$

(θ direction)

$$\begin{aligned} \rho \left(\frac{\partial v_\theta}{\partial t} + v_r \frac{\partial v_\theta}{\partial r} + \frac{v_\theta}{r} \frac{\partial v_\theta}{\partial \theta} + \frac{v_r v_\theta}{r} + v_z \frac{\partial v_\theta}{\partial z} \right) \\ = -\frac{1}{r} \frac{\partial p}{\partial \theta} + \rho g_\theta + \mu \left[\frac{1}{r} \frac{\partial}{\partial r} \left(r \frac{\partial v_\theta}{\partial r} \right) - \frac{v_\theta}{r^2} + \frac{1}{r^2} \frac{\partial^2 v_\theta}{\partial \theta^2} + \frac{2}{r^2} \frac{\partial v_r}{\partial \theta} + \frac{\partial^2 v_\theta}{\partial z^2} \right] \end{aligned}$$

(z direction)

$$\begin{aligned} \rho \left(\frac{\partial v_z}{\partial t} + v_r \frac{\partial v_z}{\partial r} + \frac{v_\theta}{r} \frac{\partial v_z}{\partial \theta} + v_z \frac{\partial v_z}{\partial z} \right) \\ = -\frac{\partial p}{\partial z} + \rho g_z + \mu \left[\frac{1}{r} \frac{\partial}{\partial r} \left(r \frac{\partial v_z}{\partial r} \right) + \frac{1}{r^2} \frac{\partial^2 v_z}{\partial \theta^2} + \frac{\partial^2 v_z}{\partial z^2} \right] \end{aligned}$$