

**UNIVERSITY OF PETROLEUM & ENERGY STUDIES
Dehradun**

Examination : End Semester Exam Dec 2017	Semester : III
Program : B.Tech (ADE)	Duration : 3 Hrs
Subject : Automotive electrical and electronics System	Max. Marks : 100
Subject Code : ADEG 213	

SECTION A

All questions are compulsory and carry equal marks. 4x5 = 20

- Q1. Illustrate role of commutator in generator and slip ring in alternator.
- Q2. Draw a circuit using electromechanical relay which will drive two different circuits
 - a. To ON DC motor (Motor required 12V DC power supply)
 - b. To ON horn system which requires 24V DC
- Q3. Elaborate need of voltage regulator. With neat diagram explain working of electromechanically type voltage regulator.
- Q4. How long lead acid battery will work if 20 amp hour battery will give 10 A of current. Assume discharge time is 20 hour and pukert constant is 0.7.
- Q5. In the below figure 1 identify the components of cut out relay of an automobile.

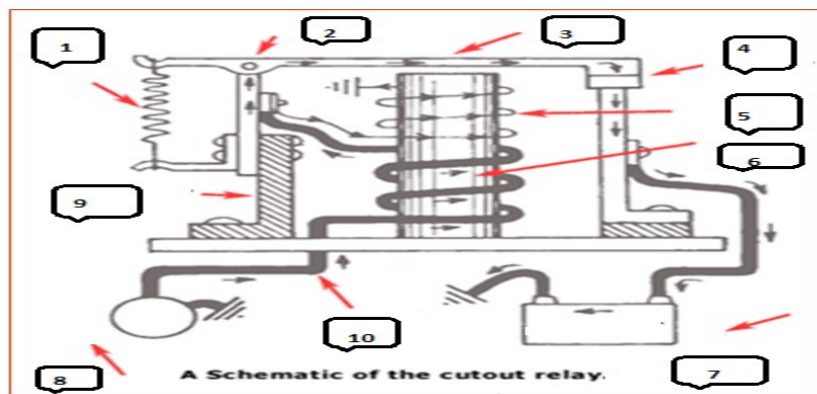

SECTION B

All questions are compulsory and carry equal marks. 5x8 = 40

- Q6. Match the following [8x1 = 8]

- | | |
|--|--|
| a. Third brush regulation | to overcome armature reaction; |
| b. Electromagnetic induction law | when conductor cuts magnetism a Voltage is induced in the conductor; Used in series configuration; |
| c. ECU used in automobile need | in kilo Volt ;
5-12 AC input;
5-12 DC input; |
| d. Positive plate | uses Pb ; |
| e. Negative Plate | Uses PbO ₂ ; |
| f. Temperature and Voltage In CCA rating | 25 deg; 1.75 V; |
| g. Temperature and Voltage In RC rating | 25 deg; 1.2V; |
| h. Voltage level in spark plug | - 18 deg; 1.2 V;
Voltage level is proportional to the rate at which the conductor cuts magnetism; For constant Voltage; |

Q7. Analyses why alternator prefers with respect with DC generator? Describe with the help of neat diagram the construction and working details of alternator.

Q8. What is third brush regulation? Elaborate the limitation of armature reaction.

Q9. Explain working of overrunning clutch based drive techniques used in conventional automobile with neat diagram.

Q10. With neat circuit diagram explain the operation of starting system.

OR

Discuss the various possible causes and their remedies for the following:

- Overcharging of batteries
- Low output from alternator/generator
- No cranking of engine , Light dim slightly
- Lamps do not give sufficient illumination

SECTION C

All questions are compulsory and carry equal marks.

2x20 =40

Q11. From below diagram assume following data:

[20]

- Crankshaft weight is 8 Kg. (Consist of Crankshaft, pistons and connecting rods for a typical internal combustion engine).
- Crankshaft required 400 RPM to start the engine.
- Gear reduction between flywheel ring gear and motor pinion gear is 18: 1
- Starter Motor rating (efficiency is 80%, Voltage = 12V).
- Starter motor shaft diameter is 15 Centimeter.



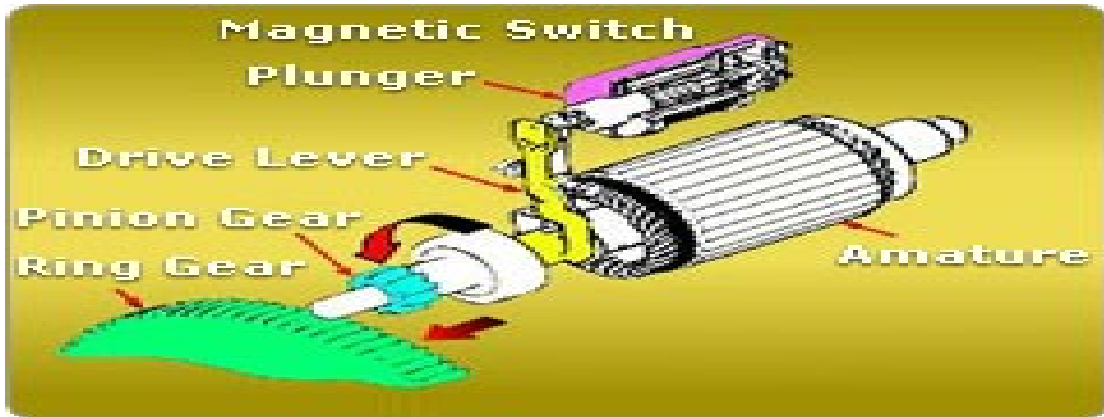

Calculate the following component:

- i. Power required to run the engine. (Without Loss) (in Horse Power)
- ii. Power required to run the engine. (With Loss) (in Horse Power)
- iii. Mechanical output in watts.
- iv. What should be RPM of the Motor?
- v. How much current required to run the Engine.
- vi. What should be rating of battery to run the engine (CCA rating)?

Q12. For the below figure determine:

a) Draw Basic Electrical circuit with respect to Voltage, resistor, Inductor, capacitor and Switches. [7]

b) Assume $L = 50 \mu\text{H}$, $R_{\text{Coil}} = 1 \Omega$, Contact Breaker Switching speed = 5000 RPM. Calculate Primary Voltage. [7]

c) If ratio of Number of turns between primary and secondary is 1: 10 then Calculate voltage developed across spark plug which is connected across secondary side of Ignition coil. [6]

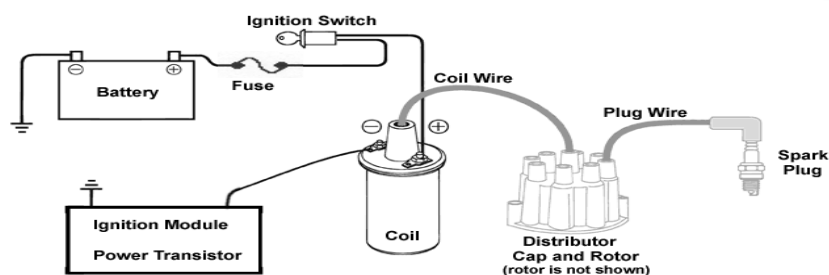

OR

A) Design a dip - dim lighting circuit with appropriate electromechanical relay. When ignition switch is OFF no light will glow. Whenever user presses **light switch** at the same time ignition switch is on then low beam of main head light should glow and whenever user presses **dip/dim switch** high beam of main head light has to glow. [10]

- B) Elaborate on board diagnosis (OBD) techniques and its different version till date. [5]
- C) Discuss Electromagnetic Interference and Compatibility with respect to automotive industry. [5]



Roll No.....

**UNIVERSITY OF PETROLEUM & ENERGY STUDIES
Dehradun**

Examination : End Semester Exam DEC 2017 Semester : III
Program : B.Tech (ADE) Duration : 3 Hrs
Subject : Automotive electrical and electronics System Max. Marks : 100
Subject Code : ADEG 213

SECTION A

All questions are compulsory and carry equal marks.

5x4 =20

- Q1. Write symbols used for following electrical devices used in Automobile [4]
- | | |
|---------------------|------------|
| Heavy duty switches | Rectifiers |
| Fuse | Condenser |
- Q2. Explain principle and operation of Air mass flow sensor used in Engine. [4]
- Q3. Make a sketch to show the speed versus torque characteristics of a series, shunt and compound motor. [4]
- Q4. What is Pukert's law? How long lead acid battery will work if 100 amp hour battery will give 10 A of current. Assume discharge time is 20 hour and Pukert constant is 1.4. [4]
- Q5. Describe with the help of illustration the principle of a direct current generator of an automobile. How the field winding and armature winding is connected in generator? [4]

SECTION B

All questions are compulsory and carry equal marks.

5x8 =40

- Q6. What is voltage regulator? With neat diagram explain working of electromechanically type voltage regulator. [8]
- Q7. A) What is alternator? [2]

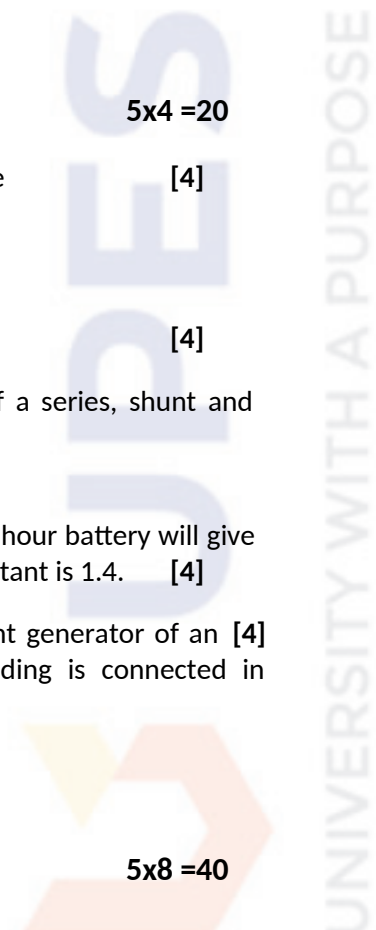

- B) Differentiate alternator and generator. [3]
 C) In the below diagram how current is flowing in charging circuit. [3]

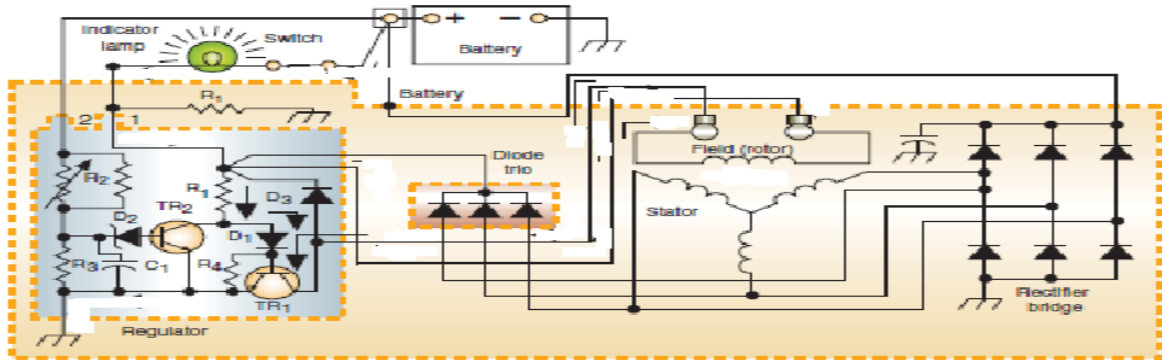

Q8. What is armature reaction? With neat diagram explain it clearly. [8]

OR

Explain role of commutator in generator and slip ring in alternator. [8]

Q9. Match the following [8]

- | | |
|--|---|
| a. Voltage level in spark plug | 25 deg; 1.75 V;
Generator |
| b. Third brush regulation | 5-12 V DC input;
to overcome armature reaction;
when conductor cuts magnetism a
Voltage is induced in the conductor;
used in shunt configuration; |
| c. Electromagnetic induction law | in kilo Volt ;

5-12V AC input;

used in Compound configuration; |
| d. ECU used in automobile need | uses Pb ;
Uses PbO ₂ ;
used in series configuration; |
| e. Positive plate | 25 deg; 1.2V;
- 18 deg; 1.2 V;
Voltage level is proportional to the rate
at which the conductor cuts magnetism;
For constant Voltage |
| f. Stator motor | |
| g. Temperature and Voltage In CCA rating | |
| h. Temperature and Voltage In RC rating | |

OR

Explain starting system with neat diagram. Also explain the operation of the cranking motor. [8]

Q10. In the below figure identify the component. Also explain working of folo thru drive mechanism used in conventional automobile. [8]

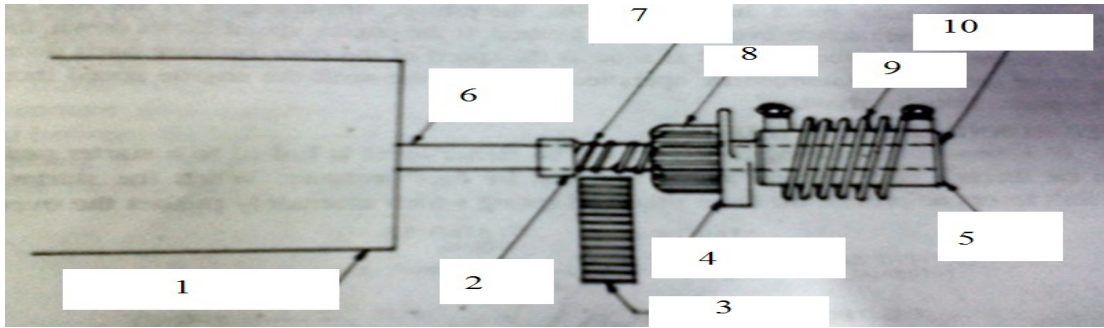

OR

Discuss following automotive technology (Any two)

[8]

- a. CAN bus system
- b. In Vehicle Networking
- c. Wire harness system

SECTION C

All questions are compulsory and carry equal marks.

2x20 =40

Q11. A) Explicate the various possible causes and their remedies for the following: [12]

- a. Overcharging of batteries
- b. Run down battery
- c. No output from alternator/generator
- d. Low output from alternator/generator
- e. No cranking of engine, No light
- f. No cranking of engine , Light dim slightly
- g. Solenoid plunger chatters
- h. Lamps do not give sufficient illumination

B) Design a dip - dim lighting circuit with appropriate electromechanical relay. When ignition switch is OFF no light will glow. Whenever user presses **light switch** at the same time ignition switch is on then low beam of main head light should glow and whenever user presses **dip/dim switch** high beam of main head light has to glow. [08]

Q12. A) Why cut relay has two types of winding i.e series and shunt winding. With neat diagram explain cut out relay. [10]

B) Make a clearly labelled sketch of the engagement and disengagement mechanism of an overrunning clutch type starter. [10]

OR

A 4-pole, 220 V DC series motor has a wave connected armature with 1200 conductors. The flux per pole is 20×10^{-3} wb, when the motor is drawing 46A. Iron and friction losses amount to 900W. Armature and series field resistance are 0.25Ω and 0.15Ω respectively. Find followings

[20]

- a. Speed of motor
- b. Total torque
- c. Shaft Power

d. Shaft Torque

e. Efficiency of motor