

Roll No: -----



**UNIVERSITY OF PETROLEUM AND ENERGY STUDIES**

End Semester Examination, December 2017

Program/course: B.Tech.Civil Engineering (Spl. Infrastr)

Semester – V

Subject: Design of Concrete Structures

Max. Marks : 100

Code : CEEG 311

Duration : 3 Hrs

No. of page/s: 2

**Note: IS 456:2000 & SP-16 Should be given/allowed to every Student**

(Answer all questions of Section A & B and 2 question from Section C)

(Assume all the necessary data if required)

**Section A ( attempt all questions)**

1.	Name three different types of reinforced concrete beams and their specific applications.	[5]	CO1
2.	State the minimum and maximum amounts of $A_{sc}$ and $A_{st}$ in doubly reinforced beams.	[5]	CO1
3.	Determine the anchorage length of 4-20T reinforcing bars going into the support of the simply supported beam shown in. The factored shear force $V_u = 280$ kN, width of the column support = 300 mm. Use M 20 concrete and Fe 415 steel.	[5]	CO1
4.	The tensile steel of a simply supported T-beam of 8 m span using M 20 and Fe 415 subjected to dead load of 9.3 kN/m and imposed loads of 10.7 kN/m at service. Calculate the short- term deflection and check the requirements of IS 456.	[5]	CO1
<b>Section B ( attempt all questions)</b>			
5.	Design a short circular column subjected to a factored load of 1400 kN and a factored moment of 90 kNm. Adopt M25 concrete and Fe415 grade steel and assume mild environment. Design; (a) with helical reinforcement (b) with hoop reinforcement	[20]	CO2, CO3, CO4
6.	Design an isolated footing for a square column of size 400mm x 400mm, supporting a service load of 2200kN. Assume SBC of soil as 250kN/m <sup>2</sup> at a depth of 1.5m below the	[20]	CO2, CO3, CO4

	ground. Use M20 concrete and Fe415 steel for the footing and M30 concrete and Fe 415 steel for the column. Assume that the column is reinforced with eight 25mm bars.		
<b>Section C ( attempt two questions)</b>			
7.	The slab of residential building of size 4.3m x 6m is simply supported on all the four sides on 230mm walls. Assuming an imposed load of 2kN/m <sup>2</sup> and load due to finishes of 1kN/m <sup>2</sup> , design the floor slab. Use M25 concrete and Fe 415 steel. Assume mild exposure.	[20]	CO2, CO3, CO4
8.	Design a staircase consisting of 10 steps having 300mm tread and 160mm rise and two landings. The width of staircase is 1500mm and the length of each landing is 1200mm. the arrangement of staircase is of stair with slab canilevering from spine beam. Assume the imposed load as 5kN/m <sub>2</sub> and mild exposure, and use M20 concrete and Fe 415 steel.	[20]	CO2, CO3, CO4
9.	A cantilever beam projects 2.5m beyond the fixed end, and carries a super imposed load of 12kN/m. Design the cantilever, using M20 concrete and Fe 415 steel. The width of support is 350mm	[20]	CO2, CO3, CO4

Roll No: -----



**UNIVERSITY OF PETROLEUM AND ENERGY STUDIES**

End Semester Examination, December 2017

Program/course: B.Tech.Civil Engineering (Spl. Infrastr)

Semester – V

Subject: Design of Concrete Structures

Max. Marks : 100

Code : CEEG 311

Duration : 3 Hrs

No. of page/s: 2

**Note: IS 456:2000 & SP-16 Should be given/allowed to every Student**

(Answer all questions of Section A, B & C)

(Assume all the necessary data if required)

**Section A ( attempt all questions)**

1.	List the common steps of design of structures by any method of design.	[5]	CO1
2.	How many limit states are there? Should a structure be designed following all the limit states?	[5]	CO1
3.	Define partial safety factors of load and material. Write the expressions to determine the design load and design strength of the material from their respective characteristic values employing the corresponding partial safety factors.	[5]	CO1
4.	What is size effect of concrete? What is its role in determining the material strength of concrete?	[5]	CO1

**Section B ( attempt all questions)**

5.	Design a biaxially loaded braced rectangular column deforming in single curvature for the following data: Factored axial load= 1750 kN Factored Bending Moments $M_{ux1}$ and $M_{uy1}$ at bottom are 200kNm and 100kNm, respectively, factored bending moments $M_{ux2}$ and $M_{uy2}$ at top are 100kNm and 60kNm, respectively, unsupported length $L_u$ is 8.5m, and effective lengths $L_{ex}$ and $L_{ey}$ are 7.5m and 6m, respectively. Consider the size of column as 400mm by 550mm. Assume M25 concrete, Fe 415 steel, and moderate environment.	[20]	CO2, CO3, CO4
6.	Design a rectangular isolated footing of uniform thickness for RC column bearing a vertical load of 600kN and having a base size of 400 x 600 mm. The safe bearing capacity of soil may be taken as 120 kN/m <sup>2</sup> . Use M20 concrete and Fe 415 steel.	[20]	CO2, CO3, CO4

**Section C ( attempt all questions)**

7.	The slab of residential building of size 4.3m x 6m is simply supported on all the four sides on 230mm walls. Assuming an imposed load of 2kN/m <sup>2</sup> and load due to finishes of 1kN/m <sup>2</sup> , design the floor slab. Use M25 concrete and Fe 415 steel. Assume mild exposure.	[20]	CO2, CO3, CO4
----	--	------	---------------------

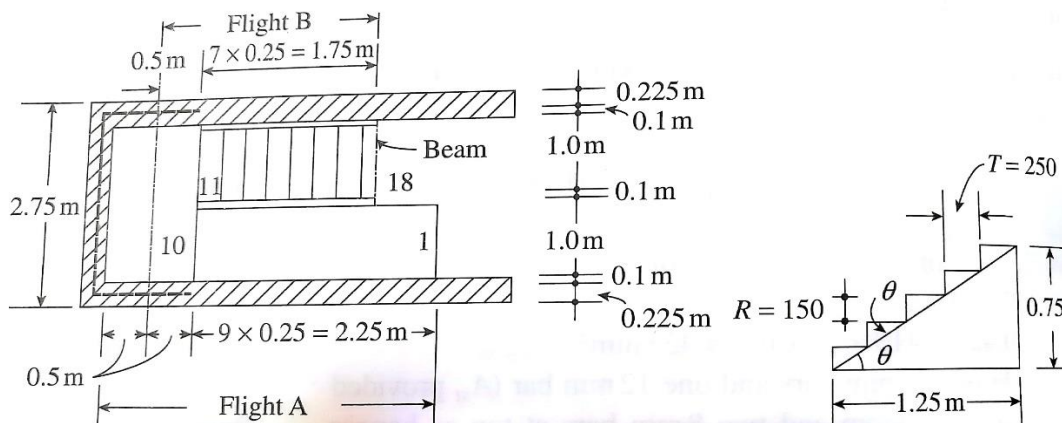
	The corners of the slab are prevented from lifting up by the wall loads due to the floor above.		
8.	<p>Design the waist slab for the longitudinally supported dog legged staircase with;</p> <p>Rise of step=150mm  Tread=250mm  Width of stair=1m  Weight of finishes=0.75 kN/m<sup>2</sup>  M20 grade concrete and Fe 415 steel  Assume mild exposure and stairs not liable for overcrowding.</p> 	[20]	CO2, CO3, CO4