

Roll No: -----



UNIVERSITY OF PETROLEUM AND ENERGY STUDIES

End Semester Examination, December 2017

Program Name: B.tech / ADE

Course Name : Two and three wheeled vehicles

Course Code : ADEG 412

No. of page/s : 04

Semester – VII

Max. Marks : 100

Duration : 3 Hrs

Section – A

(Attempt all questions. All questions carry equal marks)

(4 x 5 = 20 Marks)

1. Classify three wheeled vehicles.
2. Draw the layout of passenger auto rickshaw
3. State various types of two wheelers and specify the special features of it.
4. Mention the types of handle bar in two wheelers and state special features about it.

Section – B

(Attempt all questions. All questions carry equal marks)

(4 x 10 = 40 Marks)

5. Explain the working function of single link and double link type front suspension system of two wheelers.

(Or)

Calculate the maximum power, which should be available from the engine and the gear ratio in second gear if this power is available at 2400r.p.m, and the effective radius of the wheels is 0.419 m. An engine is required to power a vehicle having a gross weight of 20KN. The maximum grade which the vehicle will have to negotiate at 32km/hr. in second gear is expected to be 15% (percentage grade equals $\tan \theta \times 100$). The rolling resistance coefficient is 0.017 and the air resistance coefficient 0.0324 in the formula, total resistance $k_f W + k_a AV^2$ kgf, where A is in m^2 and V in km/hr. The frontal area is $5.2m^2$. The transmission efficiency in second gear is estimated to be 80%. Also, calculate the minimum speed of this vehicle in top gear on level road at the same engine speed assuming a transmission efficiency of 90% in top gear. What is the gear ratio in top gear? The differential has a reduction of 3.92.

6. Enlist various parts of two wheeler engines and state design criteria of any four major components of engines.

7. Explain the construction of drive train layout for passenger auto rickshaws.
8. Describe the working principle of any one type of electronic ignition system of two wheelers.

Section – C

(Attempt all questions. All questions carry equal marks) (2 x 20 = 40 Marks)

Note:

1. **Question number 11 is compulsory**
2. **Question number 11 must be answer in the given question paper sheets only, attach that sheet with your ANSWER SHEET by mention with roll number, and signed from invigilator.**

9. Explain with aid of neat sketch the construction of the following
 - (i) Leaf spring suspension assembly used on loading auto rickshaws
 - (ii) Hand brake operating system in three wheeler

(Or)

10. Classify loading auto rickshaw and with aid of neat sketch briefly explain the characteristics of each layout.

Signature of invigilator

Roll No:

11.

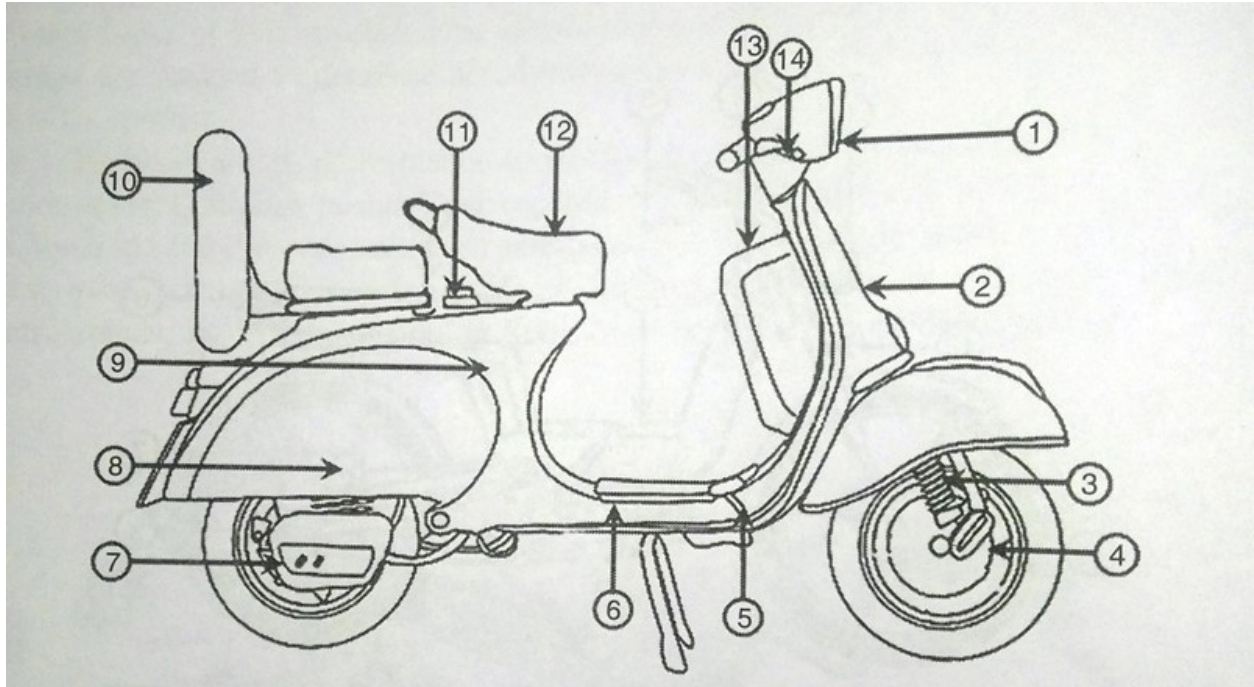

Figure-1

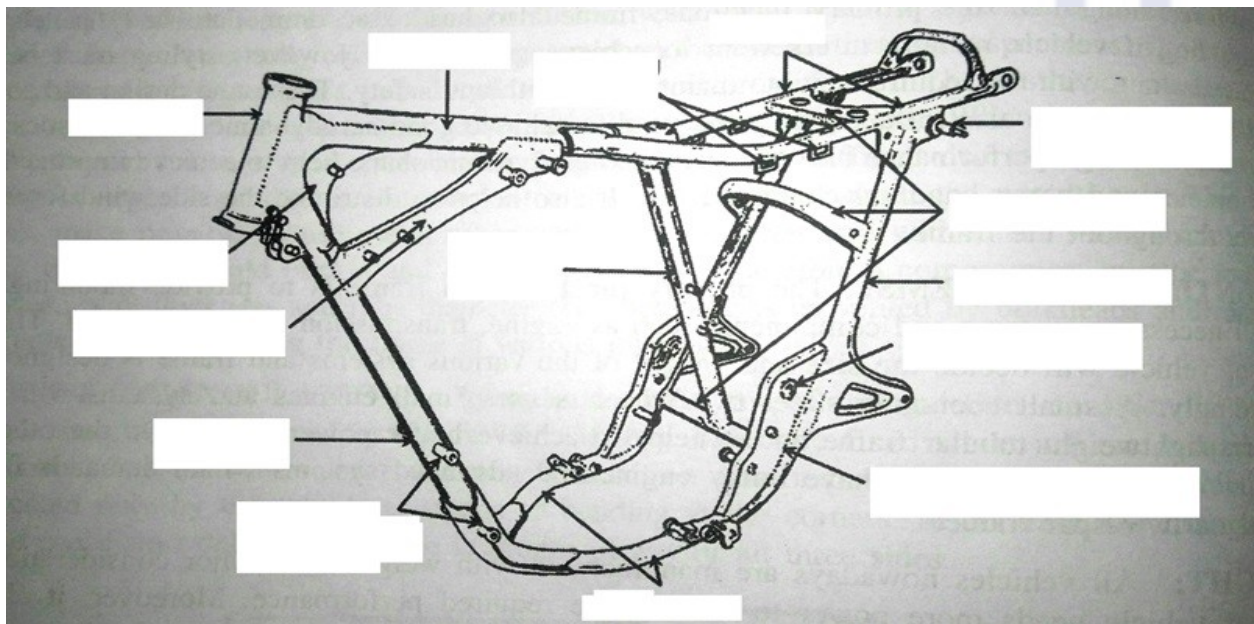

Figure-2

UNIVERSITY WITH A PURPOSE

Signature of invigilator

Roll No:

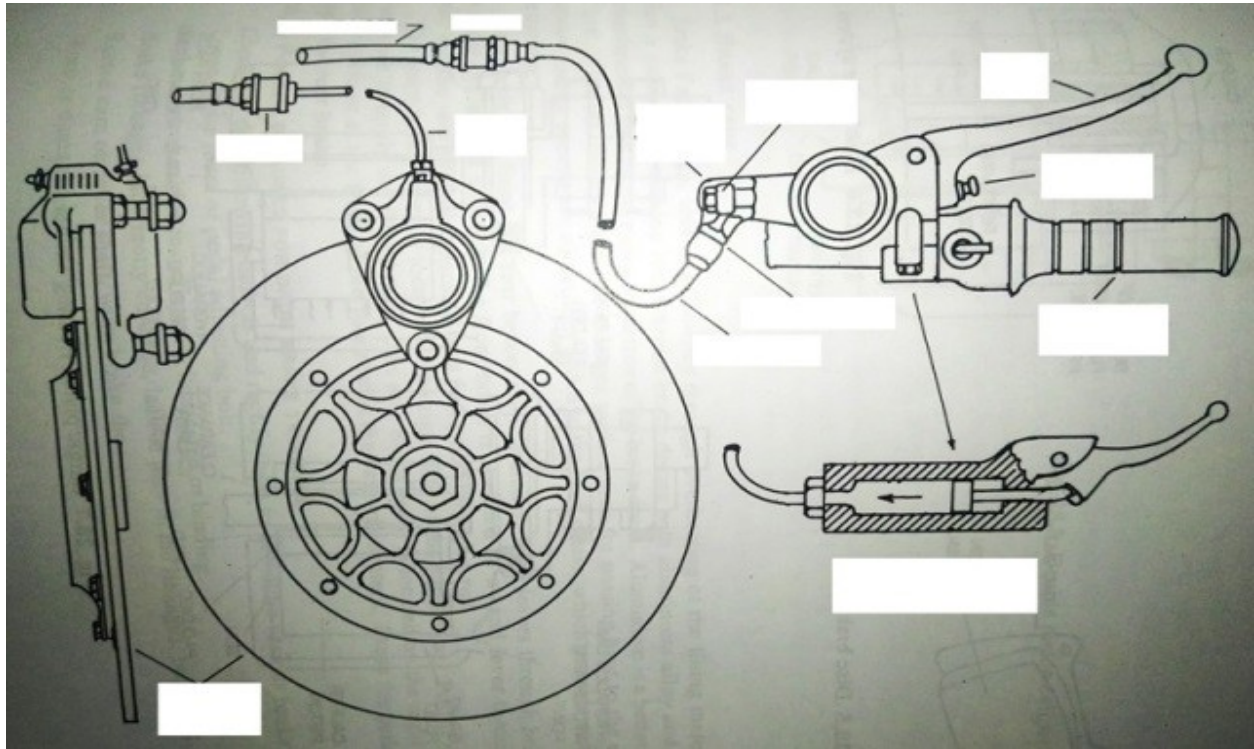

Figure-3

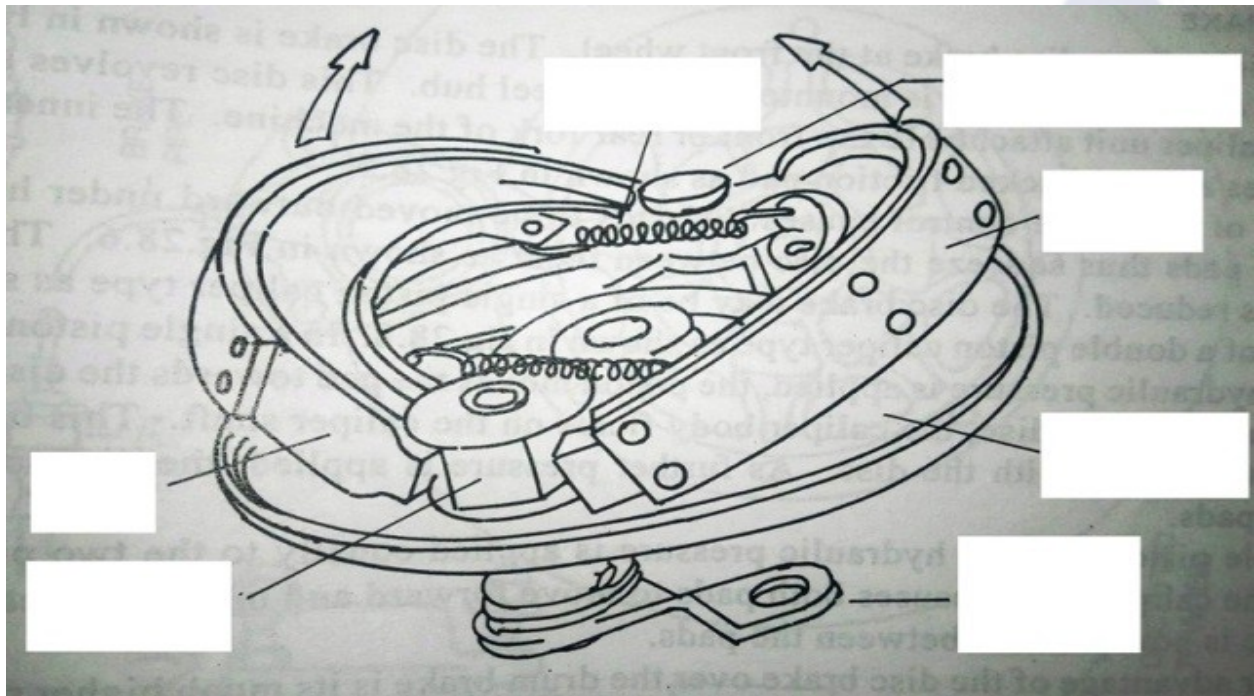

Figure-4

Roll No: -----



UNIVERSITY OF PETROLEUM AND ENERGY STUDIES

End Semester Examination, December 2017

Program Name: B.tech / ADE

Course Name : Two and three wheeled vehicles

Course Code : ADEG 412

No. of page/s : 04

Semester – VII

Max. Marks : 100

Duration : 3 Hrs

Section – A

(Attempt all questions. All questions carry equal marks)

(4 x 5 = 20 Marks)

1. Draw the schematic layout of carbureted fuel supply system of two wheelers.
2. List out various types of front and rear suspension system of two wheelers.
3. State the various types of two wheelers and three wheelers.
4. Write down the various design criteria requirement on any two-engine components of two wheelers.

Section – B

(Attempt all questions. All questions carry equal marks)

(4 x 10 = 40 Marks)

5. Compare the following,
 - a. Radial ply and cross ply tyre
 - b. Tubed and tubeless tyres.

(Or)

A motorcycle and its rider together weigh 1850 N and their combined center of gravity is 520 mm above the road when motorcycle is upright. Each wheel is of 450 mm diameter and has a moment of inertia of 1.08 kgm^2 . The moment of inertia of rotating parts of engine is 0.145 kg m^2 . The engine rotates at 5 times the speed of the vehicle and the same sense. Determine the angle of heel necessary when motorcycle is taking a turn over a track of 36 m radius at a speed of 65 Km/hr.

6. Explain the construction of rear suspension system of passenger auto rickshaw.
7. With aid of neat sketch explain the construction of handle bar assembly and state the characteristics of various types of handle bar.

8. Describe the working principle of any one type of magneto ignition system of two wheelers.

Section – C

(Attempt all questions. All questions carry equal marks) (2 x 20 = 40 Marks)

Note:

- a. Question number 11 is compulsory**
- b. Question number 11 must be answer in the given question paper sheets only, attach that sheet with your ANSWER SHEET by mention with roll number, and signed from invigilator.**

9. Classify loading auto rickshaw and with aid of neat sketch briefly explain the characteristics of each layout.

(Or)

10. Explain the following with aid of neat sketch
- a. Drive train layout for loading auto rickshaws.
 - b. Draw the layout different types of loading auto rickshaw.



Signature of invigilator

Roll No:

11.

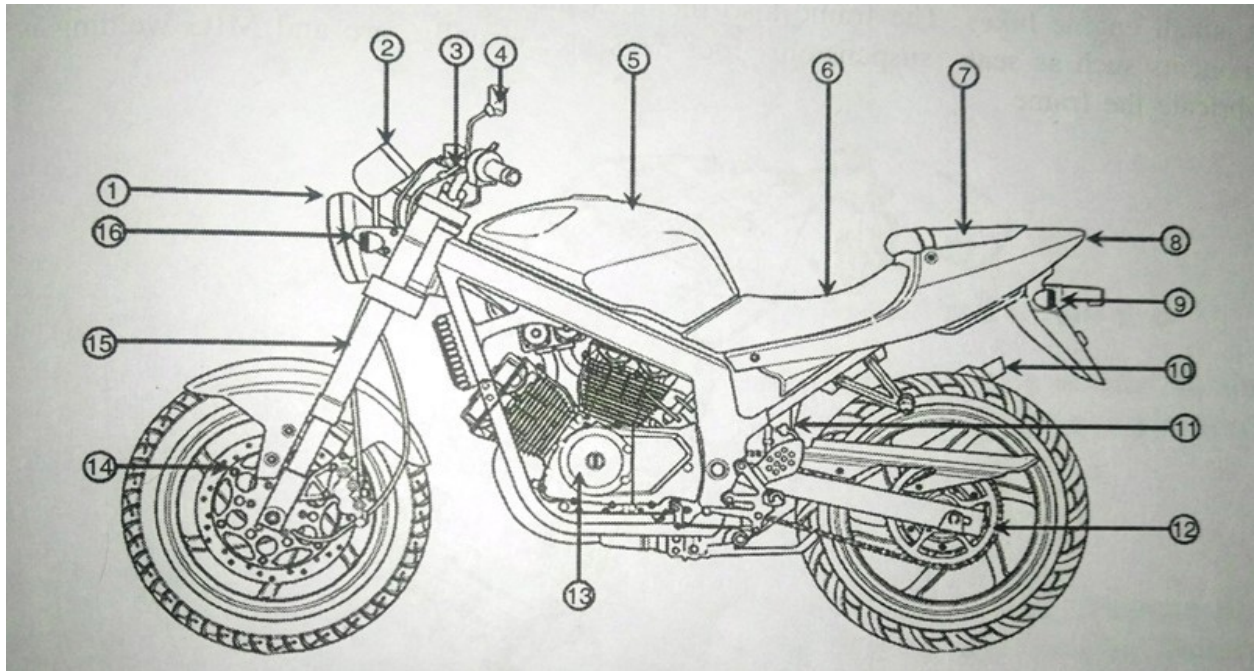

Figure-1

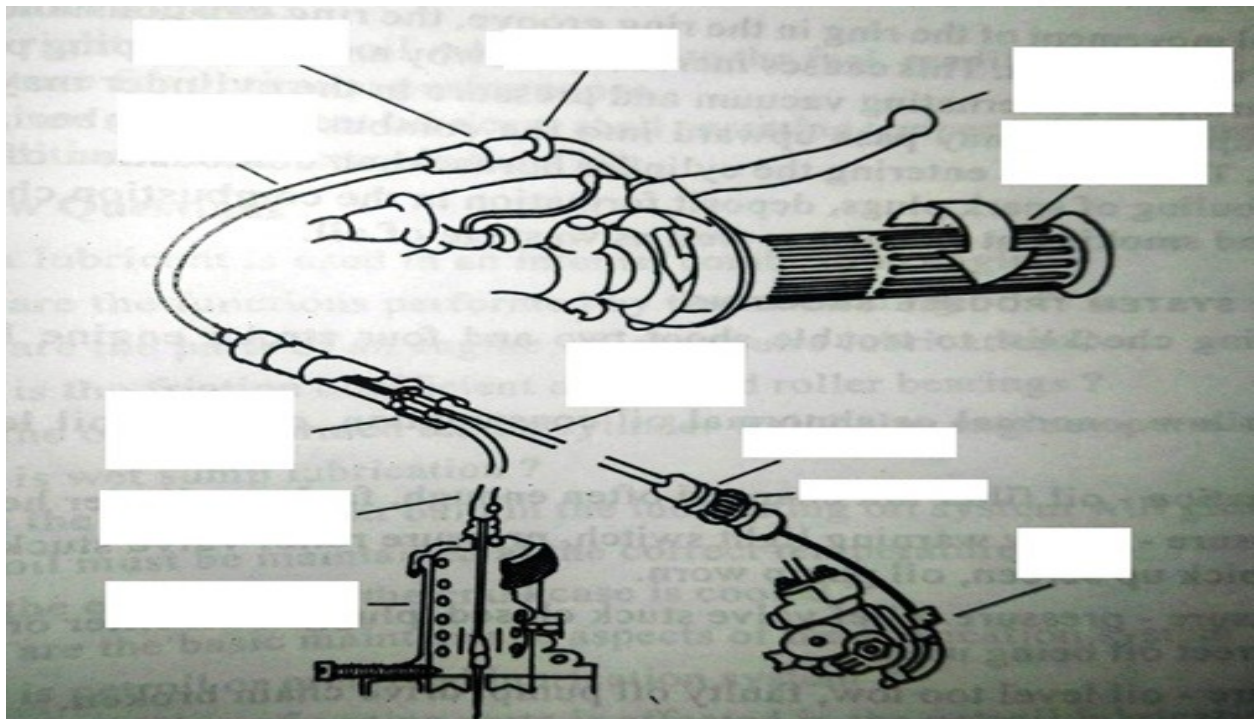

Figure-2

Signature of invigilator

Roll No:

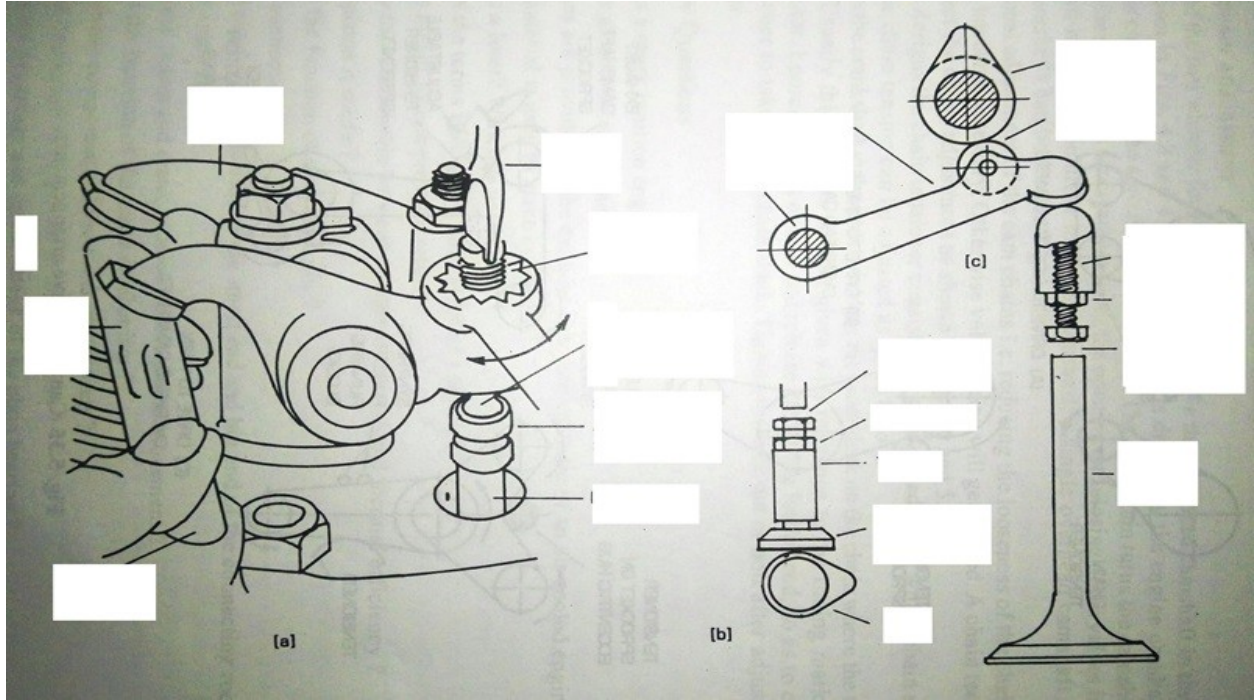

Figure-3

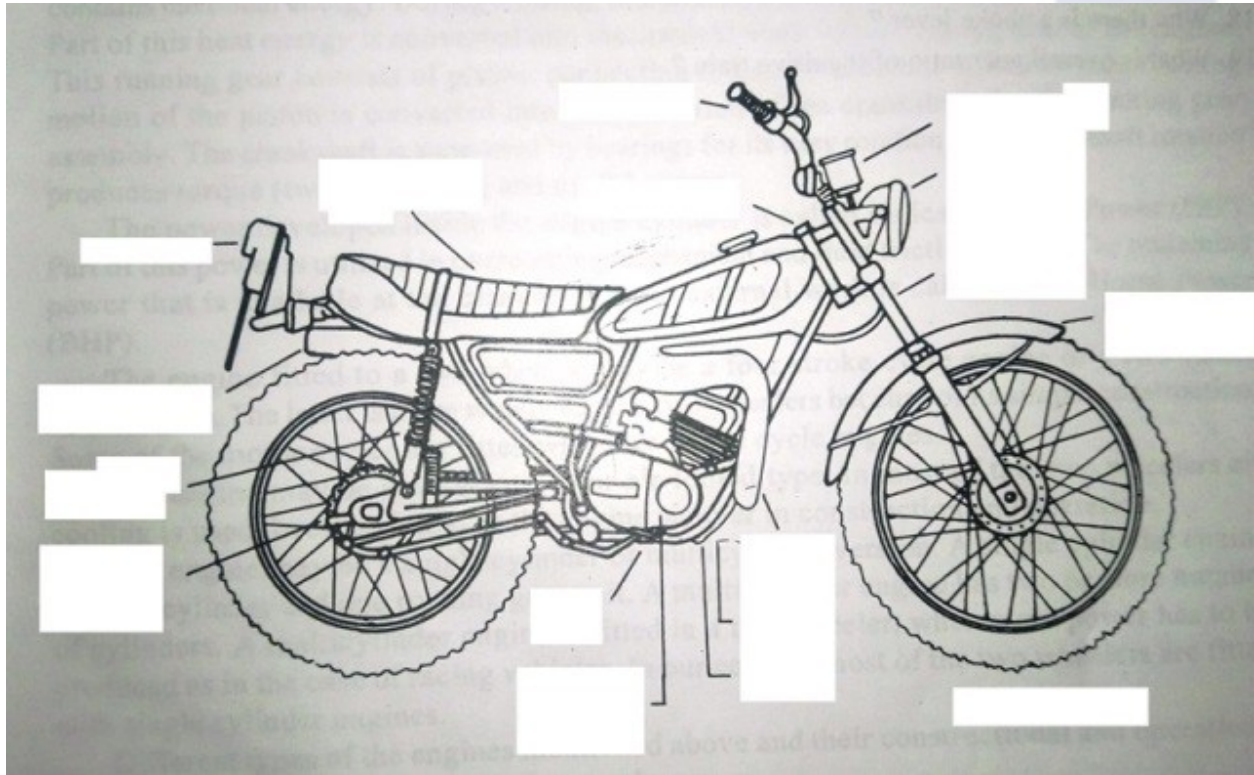

Figure-4