

Roll No: -----



UNIVERSITY OF PETROLEUM AND ENERGY STUDIES

End Semester Examination, December 2017

Program: B.Tech Instrumentation and Control Engg.

Subject (Course): SCADA and Automation

Course Code : ICEG 421

No. of page/s: 6

Semester – VII

Max. Marks : 100

Duration : 3 Hrs

-
- All questions are compulsory.
 - Mention PLC Make, Model and I/O's when required.
 - Assume, if data is unavailable.

Section A

1. Explain the concept of holding/ latching, with its application in automation industry. [5]
2. Do we have to configure alarms for all items of hardware? [5]
3. Choose the correct one: [10]
 - a. The advantage of PLC is
 - i. It has large memory capacity
 - ii. Small size and modulator design
 - iii. Requires modules for interfacing of field devices
 - iv. Programming and operation, training is required
 - b. The meaning of downloading term is
 - i. Transferring program from one PLC to other PLC
 - ii. Transferring program from output device to PLC
 - iii. Transferring program from programming device to PLC
 - iv. Transferring program from memory to PLCs CPU
 - c. If the status indicator of PLC, FORCE LED is flashing it means.
 - i. Power applied to PLC is failed
 - ii. Processor is running the program
 - iii. Processor not configured
 - iv. I/O has been forced ON or OFF
 - d. Module is used to transfer data from one PLC to another
 - i. PID
 - ii. Communication
 - iii. Isolated
 - iv. RTD
 - e. For connection of input-output devices to PLC pair is used

- i. Sinking-sinking
 - ii. Sourcing-sourcing
 - iii. Sinking-sourcing or sourcing- sinking
 - iv. None of the above
- f. The files are stored in of PLC
 - i. Hardware
 - ii. CPU
 - iii. Module
 - iv. Memory
- g. instruction, is the conditional instruction that triggers an event to occur one time.
 - i. One shot rising
 - ii. Unlatch
 - iii. Latch
 - iv. Output energize
- h. instruction is used to test whether one value is less than or equal to another.
 - i. Less than
 - ii. Less than or equal
 - iii. Greater than
 - iv. Masked comparison for equal
- i. Preparing a control system for start up is called
 - i. Commissioning
 - ii. Installation
 - iii. Mounting
 - iv. Testing
- j. If scan time of PLC small, the cost of PLC is
 - i. More
 - ii. Less
 - iii. Moderate
 - iv. Does not depend on scan time

Section B

4. In a process plant liquid A is mixed with liquid B in the following sequence: [12]
- a. If start button is pressed, the system will start operations; if stop button is, pressed system will terminate operations.
 - b. Liquid A is filled into tank by operating valve VIN1, till the level reaches to middle level (M).
 - c. Liquid B is filled into, tank by opening valve VIN2, till the level reaches to U

- d. Move stirrer 20 seconds for mixing the liquids.
- e. Take out liquid from tank by opening valve V_{out} , till liquid level reaches to L.
- f. Go to step no. b

Develop a PLC program to achieve the sequence.

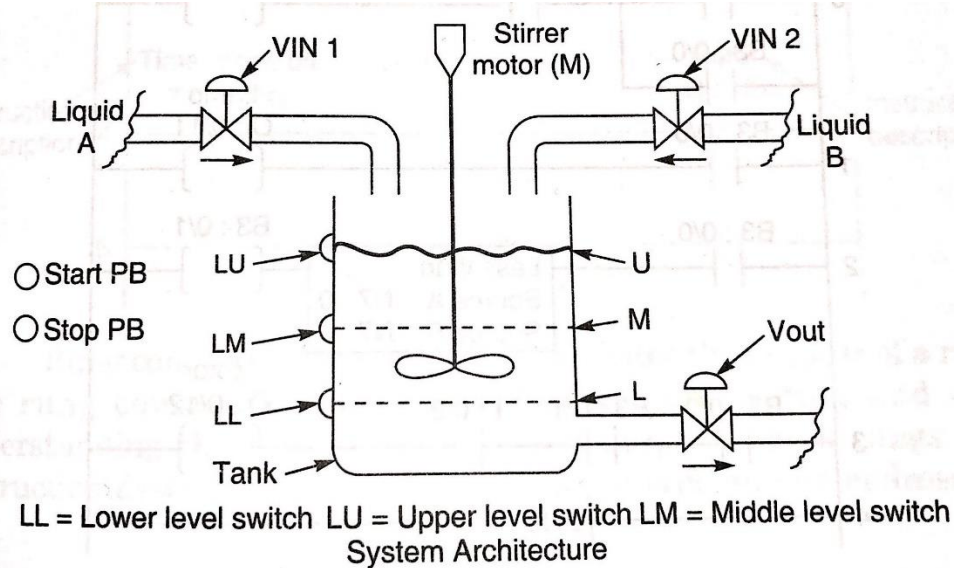

5. Can the PLC and SCADA system be expanded, without re-engineering, to handle future requirements? [5]
6. Design an interfacing circuit for both source type of sensor and PLC. [8]
7. The diesel generator set systems wiring diagram is shown below. It employs four DG's. The global objective is that when there is a mains failure out of four DG's on two DG's. Develop a PLC program to implement the following control function: [15]
 - a. The system keeps monitoring the mains failure input
 - b. When mains fail the DG1 and DG3 starts automatically
 - c. In case there is a fault in DG1 then DG2 starts automatically
 - d. Similarly in case there is fault in DG3 then DG4 starts automatically
 - e. In case there is fault in DG3 or DG4 the respective DG stops
 - f. In case DG2 is running and the fault in DG1 is cleared, then DG2 shall stop and DG1 shall start automatically.
 - g. Similarly in case DG4 is running and the fault in DG3 is cleared, then DG4 shall stop and DG3 shall start automatically.

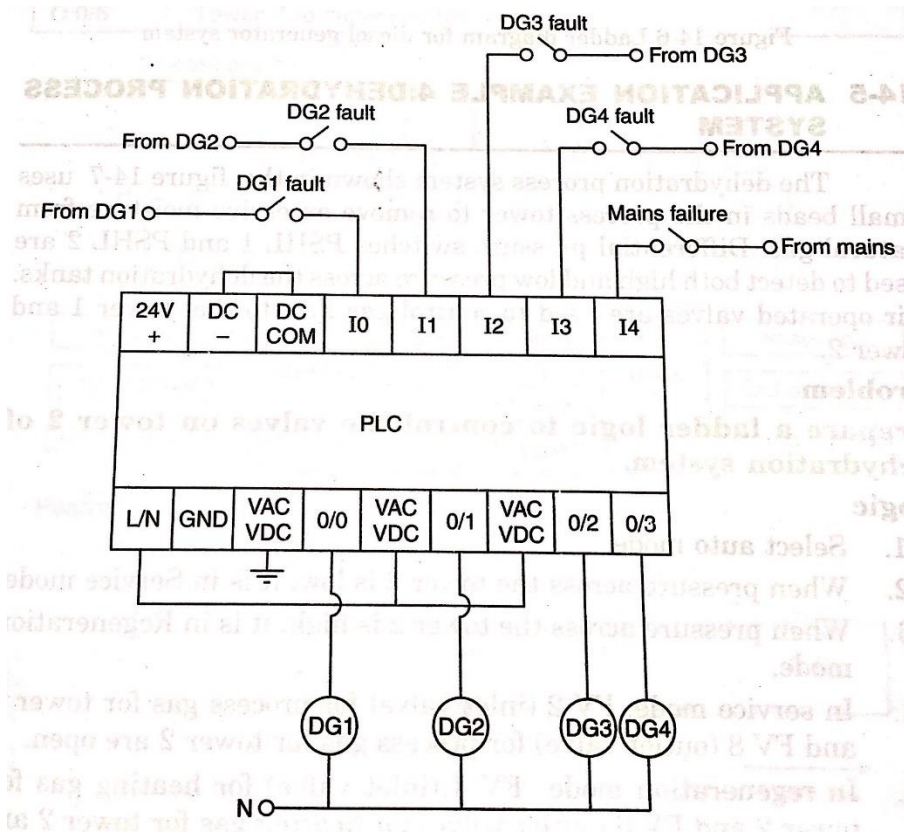

Section C

8. A buzzer game has been organized for 3 participants, following are the game buzzer control requirements for it: [20]
- After the host has finished with question.
 - The three players will press the switch in front of them to fight to be first to answer the question.
 - The buzzer will sound for 10 sec after any one of the players has touched the switch.
 - The light indicator in front of each player will light up and only reset by the host switch.

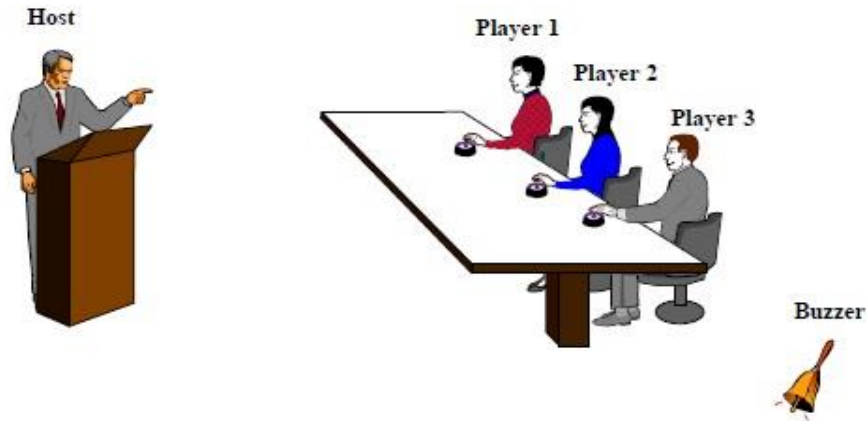

Develop a PLC ladder program to obtain the above result.

9. The water distribution system, shown in the below figure, employs distribution of pure water at 15 user points. [20]

Pure Water (PW) Inlet Valve DV05 is used as an inlet valve for water, Steam Inlet Valve XBV01 is used as inlet valve for steam and Drain Valve XFDV01 is used to drain the water.

High level switch HL SW, Medium level switch ML SW and Low level switch LL SW are used to detect high, medium and low levels of water in the tank.

Pump CFP01/02 is used for pumping the water from tank.

UV sensor is used to purify the water.

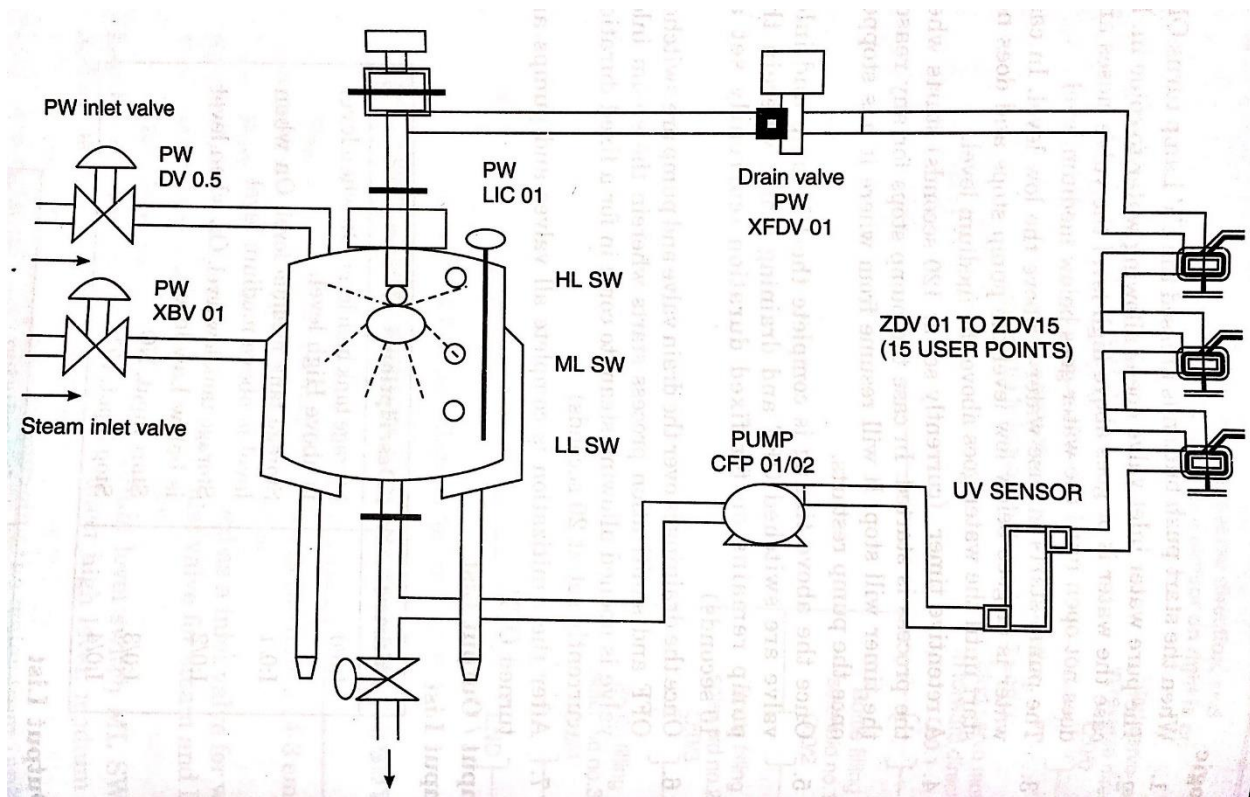

Develop a PLC program to implement the following control function:

- When the start push button is pressed the UV lamp turns ON.
- The pure water inlet valve opens allowing water to come in. In case the water is or goes above high level the valve closes and does not open until the water goes below medium level.
- The pump starts in case water is above the low level. In case water is or goes below low level the pump stops and does not start until the water goes above the medium level.
- A retentive timer (for 120 seconds) starts when the process is started. In case the pump stops for any reason, the timer will stop and resume when the pump starts.
- Once the above timing is complete the UV lamp and inlet valve are switched OFF and draining starts wherein the pump remains on for fixed duration (set at 10 seconds).
- Once the draining is over the drain valve and pump are switched OFF and sanitization process starts wherein the steam inlet valve is opened allowing steam to come in for a fixed duration (set at 20 seconds).
- After the sanitization is complete all valves and pumps are turned OFF.

Roll No: -----



UNIVERSITY OF PETROLEUM AND ENERGY STUDIES

End Semester Examination, December 2017

Program: B.Tech Instrumentation and Control Engg.

Subject (Course): SCADA and Automation

Course Code : ICEG 421

No. of page/s: 4

Semester – VII

Max. Marks : 100

Duration : 3 Hrs

-
- All questions are compulsory.
 - Mention PLC Make, Model and I/O's when required.
 - Assume, if data is unavailable.

Section-A

1. Answer the following: [5]
- True or False: An example of discrete control is:
 - Varying the volume of a music system
 - Turning a lamp ON or OFF
 - Varying the brightness of a lamp
 - Controlling the speed of a fan
 - A solenoid is an example of an output device.
 - True
 - False
 - None of the above
 - To increase the number of inputs and outputs of the PLC, one can use expansion modules.
 - True
 - False
 - None of the above
 - Which one of the following is not a PLC manufacturer?
 - Siemens
 - Mitsubishi
 - Microsoft
 - ABB
 - PLC stands for programmable logic controller.

- a. True
 - b. False
 - c. None of the above
2. Choose the correct one: [6]
- a. PLCs are designed not run on
 - i. Load
 - ii. Power
 - iii. Force
 - iv. fault
 - b. Sets the standards and sizes for PLC enclosures.
 - i. NEMA
 - ii. EMA
 - iii. ISA
 - iv. IEEE
 - c. requires practical analytical, logical skills.
 - i. PLC wiring
 - ii. I/O modules
 - iii. PLC enclosures
 - iv. Troubleshooting
 - d. In a PID controller, the offset has increased. The integral time constant has to be ___ so as to reduce offset:
 - i. Reduced
 - ii. Increased
 - iii. Reduced to zero
 - iv. None of the above
 - e. When derivative action is included in a proportional controller, the proportional band:
 - i. Increases
 - ii. Reduces
 - iii. Remains unchanged
 - iv. None of the above
 - f. In a proportional temperature controller, if the quantity under the heater increases the offset will:
 - i. Increase
 - ii. Reduce
 - iii. Remain unaffected
 - iv. None of the above
3. Implement the following digital operations using PLC ladder logic equivalent. [9]
- a. XOR Gate
 - b. OR Gate
 - c. AND Gate

Section-B

4. Consider a city gas distribution system having following configuration: [12]
- Storage and distribution facility at city gate (centralized storage facility) where SCADA master unit will also be located.
 - 1500 individual household units.
 - 50 commercial units.
 - Master nodes for each 100 household units and 10 commercial units respectively.
- Design a SCADA system along with the detailed architecture of the system so as to highlight the functioning of each and every component.
- Suggest how the system can be made more redundant.
 - Explain various communication modes and medium with various remote units.
5. Explain the architecture of SCADA system and explain in brief. [10]
6. Explain the working of optocouplers in PLC I/O modules. [10]
7. Differentiate between real time and historical trends. [8]

Section-C

8. The system shown in below figure employs washing a car in a washing chamber. [20]
It includes:
- Detecting a car in washing chamber
 - Washing a car by spraying chemical and water
 - Brushing (only upper and right side of the car)
 - Drying a car using hot air
 - START push button is used to start the process; STOP push button is used to stop the process.
 - LS limit switch is used to detect a car in washing chamber
 - M_CONVEYOR is used to drive the conveyor until the car is in a position, as indicated by car present switch LS
 - V1 valve is used to sprinkle water + chemical on a car.
 - V2 valve is used to sprinkle water on a car
 - V3 valve is used to spray hot air on a car
 - M_UPPER motor is used to move the brush on the upper side of the car.
 - M_RIGHT motor is used to move the brush on the right side of the car.
- Develop a PLC program for the following sequence:
- When START push button is pushed, the function starts.
 - On M_CONVEYOR motor, when LS is off
 - Off M_CONVEYOR motor, when LS is on.
 - On V1 valve, on M_UPPER, on M_RIGHT for 100 seconds when LS is on.
 - Off V1 valve, after 100 seconds.
 - On V2 valve, when valve V1 is off.
 - Off V2 valve, after 50 seconds.

- h. On V3 valve, when V2 valve is off.
- i. Off V3 valve, after 50 seconds.
- j. On M_CONVEYOR motor again and repeat the cycle from step *b* to *i*.

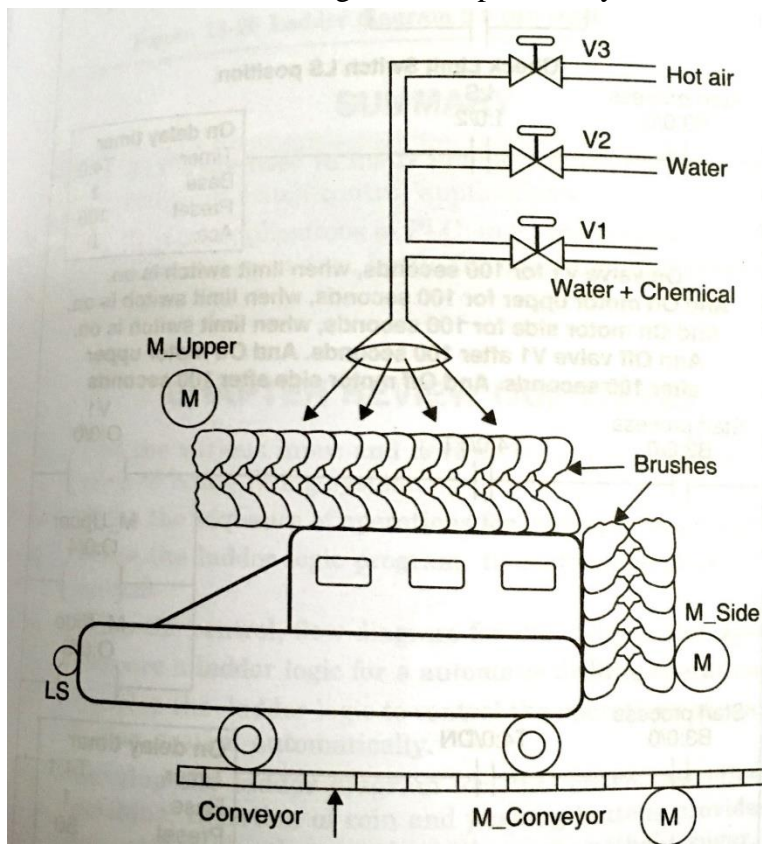

9. In a gasoline distribution center each storage tank is connected to distribution lines via 3 pumps. (2-normal operation, 1-stnadby) In auto mode the selector logic configuration is for activation of motors are as follows: [20]
- e. 1 Motor Running mode: the first pump available in the sequence will start.
 - f. 2 Motor Running mode: the second available pump will start on receiving 'ADD 1 ON' command from the control room, when the first motor trips.
 - g. 3 Motor Running mode: The third pump will start on receiving 'ADD 2 ON' from the control room, when the second motor trips.

When a motor trips, fault sensor activates. Also, the auto selector ensures that if any other pump is selected, the former pump selection shall be reset and the later shall be selected. Develop a ladder logic program to achieve so.