

Roll No: -----



UNIVERSITY OF PETROLEUM AND ENERGY STUDIES

End Semester Examination, December 2017

Program: B. Tech ASE, ASE+AVE
Subject (Course): Applied Fluid Mechanics
Course Code: GNEG225
No. of page/s: 02

Semester – III
Max. Marks : 100
Duration : 3 Hrs

Note: Make use of sketch/plots to elaborate your answer. All sections are compulsory

Section-A [5 X 4 = 20 Marks]

- 1) Explain the concept of stream function as a direct consequence of the principle of continuity. What is the value of stream function along a streamline?
- 2) What is a system? Explain the different types of system clearly stating the properties for each.
- 3) Does a velocity field given by $\vec{V} = 5x^3\vec{i} - 15x^2y\vec{j} + t\vec{k}$ represent a possible incompressible flow of a fluid?
- 4) What is a plane circular vortex flow? Derive the equation describing the velocity and pressure distribution for a free vortex flow.
- 5) What is Buoyancy? Derive the formulation to calculate the buoyant force on a submerged body.

Section-B [4 X 10 = 40 Marks]

- 6) A fluid has a viscosity of $0.048 \text{ N/m}^2\text{s}$ and a specific gravity of 0.913. For the flow of such a fluid over a flat solid surface, the velocity at a point 75 mm away from the surface is 1.125 m/s. Calculate the shear stresses at the solid boundary, at points 25 mm, 50 mm and 75 mm away from the boundary surface. Assume (i) a linear velocity distribution and (ii) a parabolic velocity distribution with the vertex at the point 75 mm away from the surface where the velocity is 1.125 m/s.
- 7) A hollow cylinder of 0.6 m diameter, open at the top, contains some liquid and spins about its vertical axis, producing a forced vortex motion.
 - (a) Calculate the height of the vessel so that the liquid just reaches the top of the vessel and begins to uncover the base at 100 rpm.
 - (b) If the speed is now increased to 130 rpm, what area of the base will be uncovered?

- 8) What is the principle of conservation of mass? Derive the continuity equation in the differential form at a point in a fluid enclosed by an elementary control volume. What force components F_x and F_y are required to hold the black box of Fig. 1 stationary? Assume no mass to be accumulated inside the black box and all pressures are zero gauge.

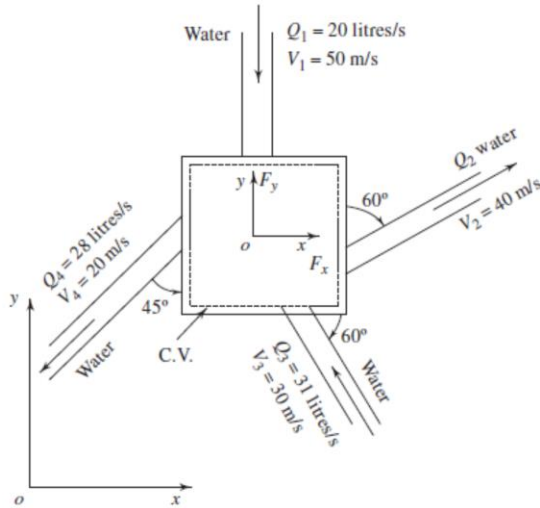

Fig. 1

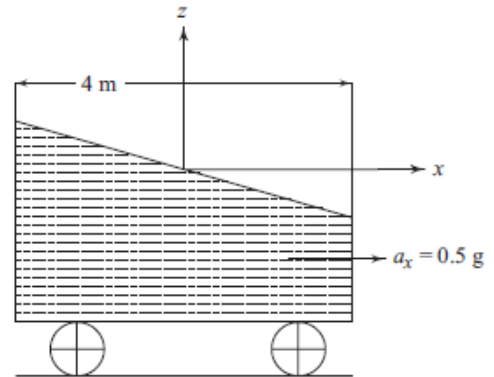

Fig. 2

- 9) Derive the equation of motion for a fluid flow with constant acceleration. Using the derived equation, determine the equation of free surface of water in a tank 4 m long, moving with a constant acceleration of 0.5 g along the x-axis as shown in Fig. 2.

Section-C [2 X 20 = 40 Marks]

- 10) Applying the Bernoulli's theorem, formulate the equation to calculate the velocity at the throat section of an inclined venturimeter. Why is the actual flow rate different than the theoretical flow rate? Water flows through a 300 mm \times 150 mm venturimeter at the rate of 0.037 m³/s and the differential gauge is deflected 1 m, as shown in the Fig. 3. Specific gravity of the gauge liquid is 1.25. Determine the coefficient of discharge of the meter.

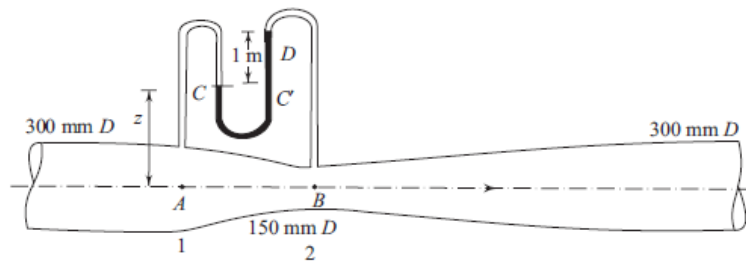

Fig. 3

- 11) Applying the momentum theorem for an inertial control volume, derive the equation to calculate the forces due to flow through an expanding pipe bend.

OR

Derive the equation to calculate the dynamic forces on an inclined plane surface due to the impingement of liquid jet.

Roll No: -----



UNIVERSITY OF PETROLEUM AND ENERGY STUDIES

End Semester Examination, December 2017

Program: B. Tech ASE, ASE+AVE
Subject (Course): Applied Fluid Mechanics
Course Code: GNEG225
No. of page/s: 02

Semester – III
Max. Marks : 100
Duration : 3 Hrs

Note: Make use of sketch/plots to elaborate your answer. All sections are compulsory

Section-A [5 X 4 = 20 Marks]

- 1) In a 1-D flow field, the velocity at a point may be given in the Eulerian system by $u = x + t$. Determine the displacement of a fluid particle whose initial position is x_0 at initial time t_0 in the Lagrangian system.
- 2) Explain the principle applied for a barometer. Mention few applications.
- 3) What is Buoyancy? Derive the formulation to calculate the buoyant force.
- 4) Derive the Pascal's Law that gives the state of force for a fluid at rest.
- 5) What is the principle of conservation of mass? State the continuity equation in a cylindrical polar coordinate system.

Section-B [4 X 10 = 40 Marks]

- 6) A cylinder contains 0.35 m^3 of air at 50°C and 276 kN/m^2 absolute. The air is compressed to 0.071 m^3 .
 - (a) Assuming isothermal conditions, what is the pressure at the new volume and what is the isothermal bulk modulus of elasticity at the new state.
 - (b) Assuming isentropic conditions, what is the pressure and what is the isentropic bulk modulus of elasticity? (Take the ratio of specific heats of air $\gamma = 1.4$)
- 7) A closed cylinder 0.4 m in diameter and 0.4 m in height is filled with oil of specific gravity 0.80. If the cylinder is rotated about its vertical axis at a speed of 200 rpm, calculate the thrust of oil on top and bottom covers of the cylinder.
- 8) Derive the Bernoulli's equation under the special condition where the constant C becomes independent of the streamline and is applicable to the entire flow.

- 9) Water flows upwards through a vertical 300 mm × 150 mm Venturimeter whose coefficient is 0.98. The deflection of a differential gauge is 1.18 m of liquid of specific gravity 1.25, as shown in Fig. 1. Determine the flow rate in m³/s.

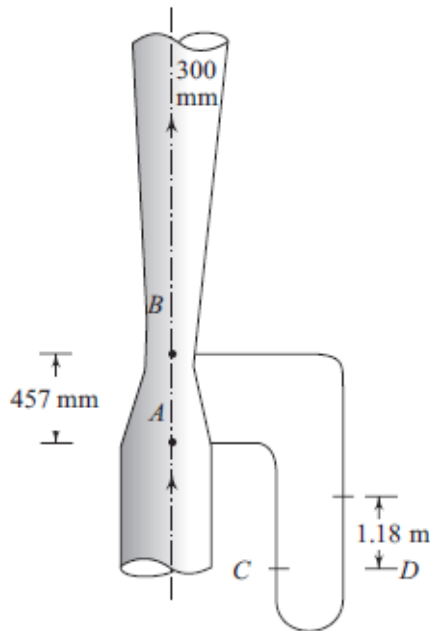

Fig. 1

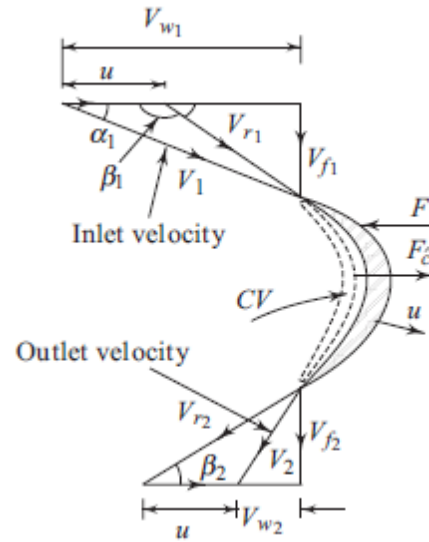

Fig. 2

Section-C [2 X 20 = 40 Marks]

- 10) An open rectangular tank of 5 m × 4 m is 3 m high and contains water up to a height of 2 m. The tank is accelerated at 3 m/s²
- horizontal along the longer side
 - vertically upwards
 - vertically downwards and
 - in a direction inclined at 30° upwards to the horizontal along the longer side.

Draw in each case, the shape of the free surface and calculate the total force on the base of the tank as well as on the vertical faces of the container. At what acceleration will the force on each face be zero?

- 11) State the Reynolds Transport Theorem and apply it to the conservation of momentum achieve the formulation for the linear momentum equation. Validate the achieved formulation by deriving the momentum equation at a point in a fluid enclosed by an elementary control volume.

OR

Applying the momentum theorem, analyze the forces on a moving curved vane from the study of the inlet and outlet velocity triangles as shown in the Fig. 2. What would be the magnitude and direction of the net force exerted on the vane?